

2013 EPA CERTIFIED CHASSIS ELECTRICAL SCHEMATICS

THIS MANUAL HAS BEEN DESIGNED AS AN AID FOR TROUBLESHOOTING THE H.M.E. CUSTOM FIRE TRUCK CHASSIS. IT'S CONTENT AND ANY SUPPORTING DOCUMENTATION HAS BEEN PROVIDED ON A RESTRICTED BASIS AND IS NOT TO BE USED IN ANY MANNER DETRIMENTAL TO THE INTERESTS OF H.M.E. INCORPORATED.

IT SHOULD BE NOTED THAT SOME FEATURES ARE OPTIONAL AND NOT ALL FEATURES ARE AVAILABLE ON ALL CHASSIS LINES. IT SHOULD ALSO BE NOTED THAT AS H.M.E. CHASSIS ARE CUSTOM BUILT SOME OF THE SYSTEMS DEFINED IN THIS MANUAL MAY HAVE BEEN MODIFIED. SEE SUPPORTING DOCUMENTATION FOR ANY SUCH MODIFICATIONS.

WHILE EVERY EFFORT WILL BE MADE TO MAINTAIN THE ACCURACY OF THIS MANUAL ACTUAL PRODUCTION PROCEDURES MAY CHANGE ANYTIME GOOD ENGINEERING PRACTICE DEEMS NECESSARY.

THIS PAGE LEFT INTENTIONALLY BLANK

CONTENTS

HARNESS ROUTING

CAB – SPECTR _____	6
1871/SFO/VC/W _____	7
CHASSIS (ALL MODELS) _____	8

FUSE/RELAY PANELS (STANDARD LAYOUTS)

SPECTR (MULTIPLEXED) _____	9
1871/SFO/VC/W (MULTIPLEXED) _____	10
SPECTR (NON-MULTIPLEXED) _____	11
1871/SFO/VC/W (NON-MULTIPLEXED) _____	12

MULTIPLEXING

OVERVIEW – IDENTIFYING A MULTIPLEXED HME CHASSIS _____	13
COMPONENT LOCATIONS/BUS ROUTING – SPECTR _____	14
ALL OTHERS _____	15
DIAGNOSTICS – DISPLAY ACCESS _____	16
DISPLAY MENU TREE _____	17
DIAGNOSTIC INDICATORS (MODULES) _____	18
DIAGNOSTIC INDICATORS (SWITCH PANEL, DISPLAY) _____	19
PRIMARY MODULE CONNECTIONS (PWR, GND, & BUS) _____	20, 21, 22
GATEWAY INTERFACE (DIAGNOSTIC/PROGRAMMING CONNECTION) _____	23
BUS TERMINATION _____	24
BUS TROUBLESHOOTING TIPS _____	25

BATTERY/IGNITION

BATTERY+ DISTRIBUTION (CAB) _____	26
IGNITION BUS – ALL MULTIPLEXED _____	27
SPECTR NON-MULTIPLEXED _____	28
1871/SFO/VC/W NON-MULTIPLEXED _____	29

INTERIOR LIGHTING

ALL MULTIPLEXED _____	30
DOOR SWITCH INPUTS (MULTIPLEXED CHASSIS) _____	31
ALL NON-MULTIPLEXED _____	32, 33

EXTERIOR LIGHTING (DOT)

HEADLAMPS – NON-MULTIPLEXED WITHOUT WIG/WAG _____	34
NON-MULTIPLEXED WITH WIG/WAG _____	35
MULTIPLEXED (WITH OR WITHOUT WIG/WAG) _____	36
TAIL/MARKER LIGHTS – MULTIPLEXED _____	37
NON-MULTIPLEXED _____	38
STOP/TURN/HAZZARD – MULTIPLEXED _____	39
NON-MULTIPLEXED _____	40

CONTENTS (CONT.)

HORNS (AIR AND ELECTRIC)

NON-MULTIPLEXED _____	72
MULTIPLEXED _____	73

BODY BUILDERS INTERFACES (CHASSIS)

NON-MULTIPLEXED _____	74
MULTIPLEXED _____	75
LIGHTBAR INTERFACE (MULTIPLEXED) _____	76

SEE SWITCH PANEL SCHEMATICS FOR NON MULTIPLEXED CHASSIS.

COMMON OPTIONS _____ 77

APPENDIX

COMMONLY USED SYMBOLS _____	98
MAINTENANCE/TROUBLESHOOTING TIPS _____	99
CHANGE LOG _____	100

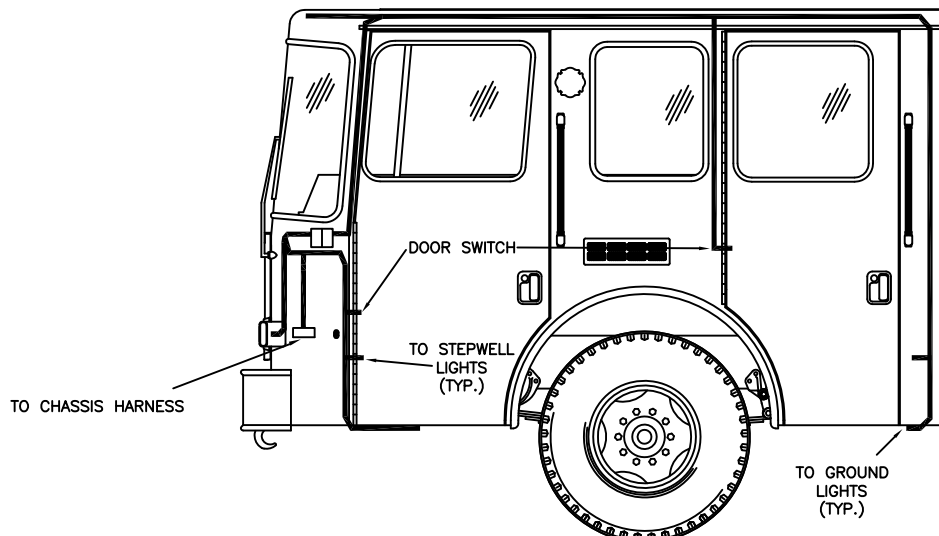
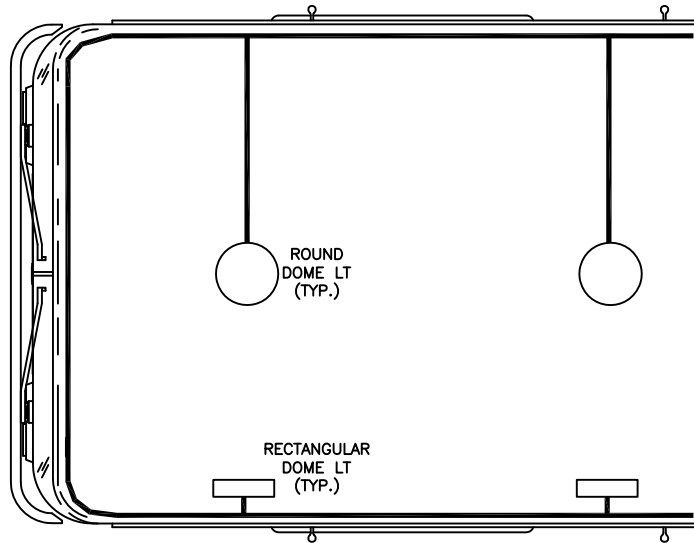
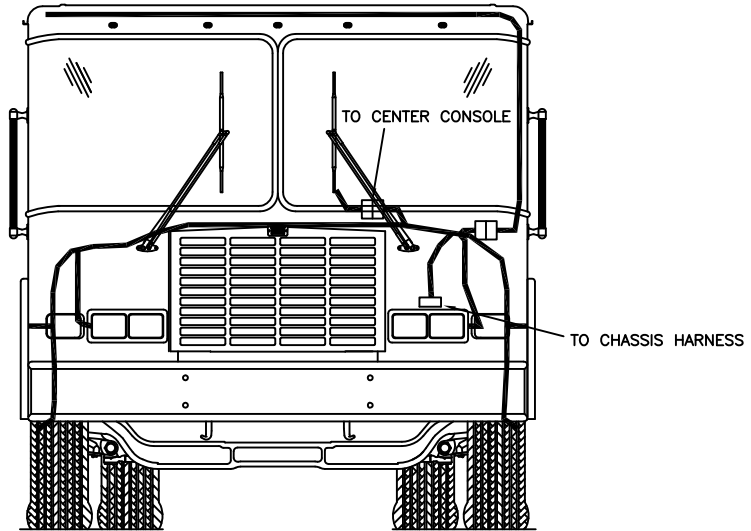

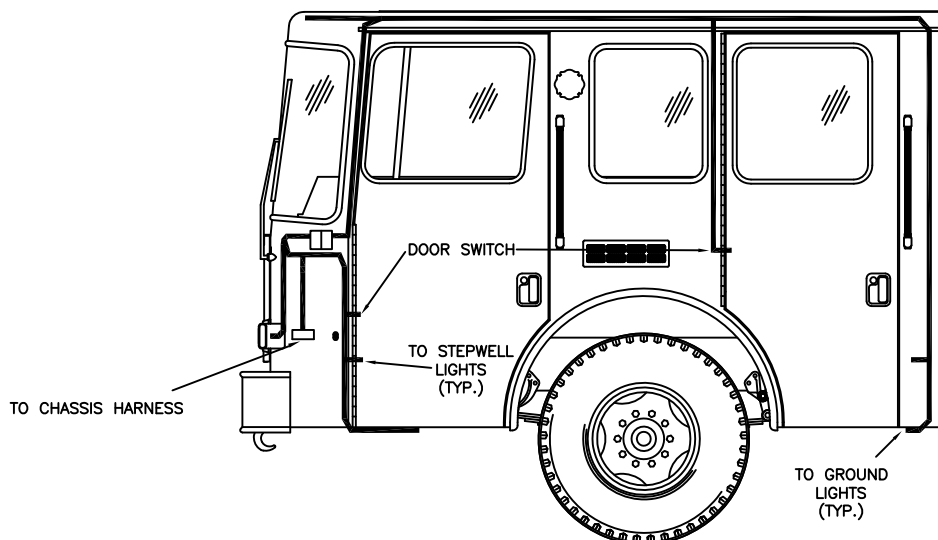
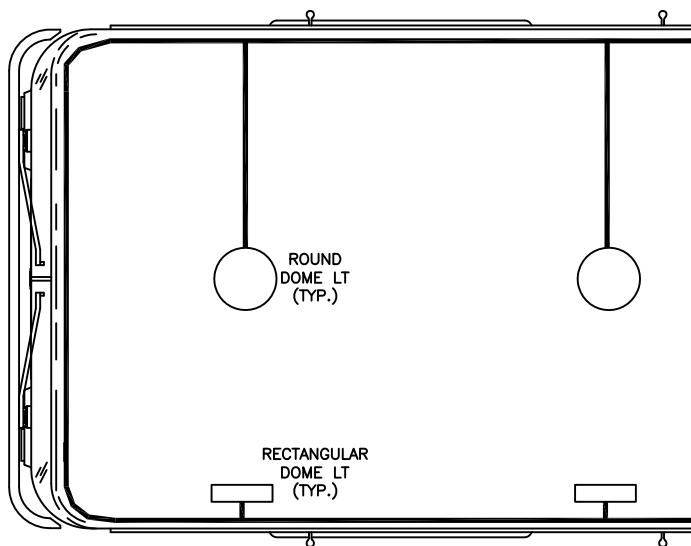
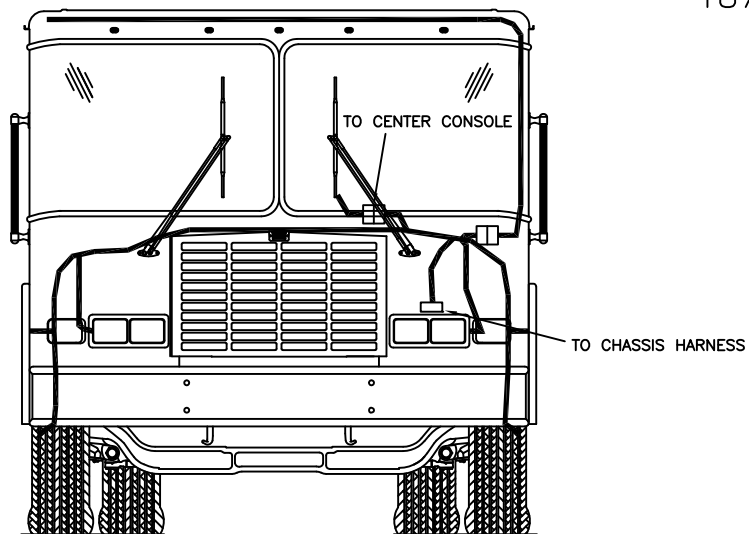

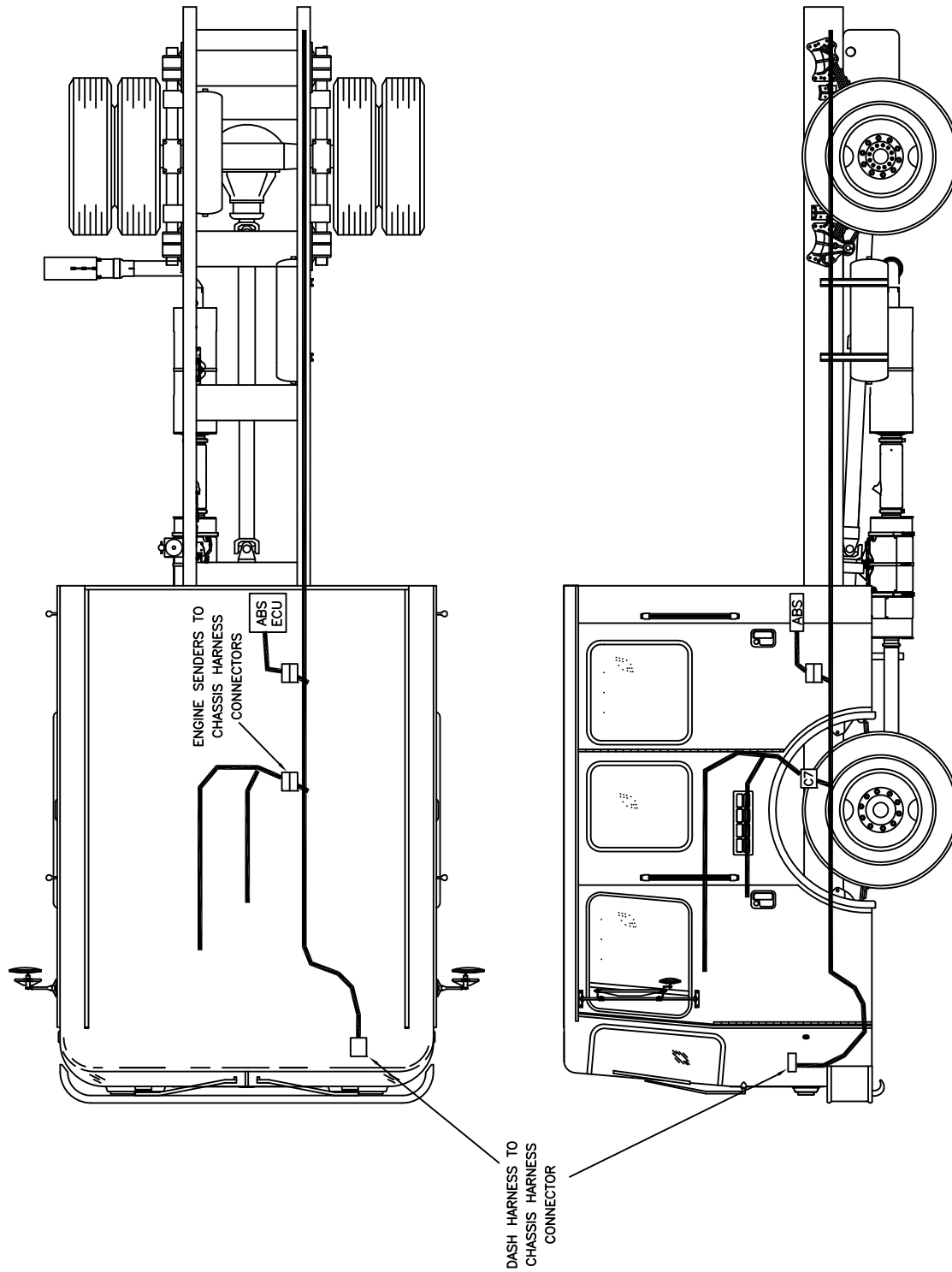

FUSE/RELAY PANELS

SPECTR (MULTIPLEXED)

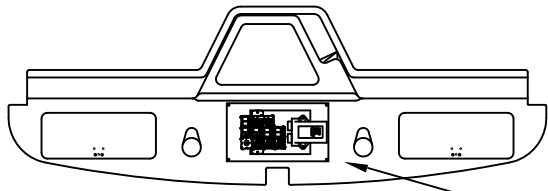

- F0 LIGHTBAR BRW
- F1 LIGHTBAR CRW
- F2 LIGHTBAR LOAD MANAGED
- F3 REAR STEP/GROUND LIGHTS
- F4 OPEN COMPARTMENT LIGHT
- F5 CLEARANCE LIGHTS
- F6 CLEAR DOME LIGHTS STANARD
- F7 EXTRA CLEAR DOMES
- F8 FUSE FOR RELAY R8
- F9 FUSE FOR RELAY R9
- F10 FUSE FOR RELAY R10
- F11 FUSE FOR RELAY R11
- F12 FUSE FOR RELAY R12
- F13 FUSE FOR RELAY R13
- F14 FUSE FOR RELAY R14
- F15 FUSE FOR RELAY R15
- F16 ROOF TOP A/C CONDENSOR
- F17 RED DOME LIGHTS
- F18 OVERHEAD MUX MODULES
- F19 OVERHEAD SPOT LIGHTS
- F20 OVERHEAD SIREN (OR SPARE)
- F21 STEREO (OR SPARE)
- F22 SPARE

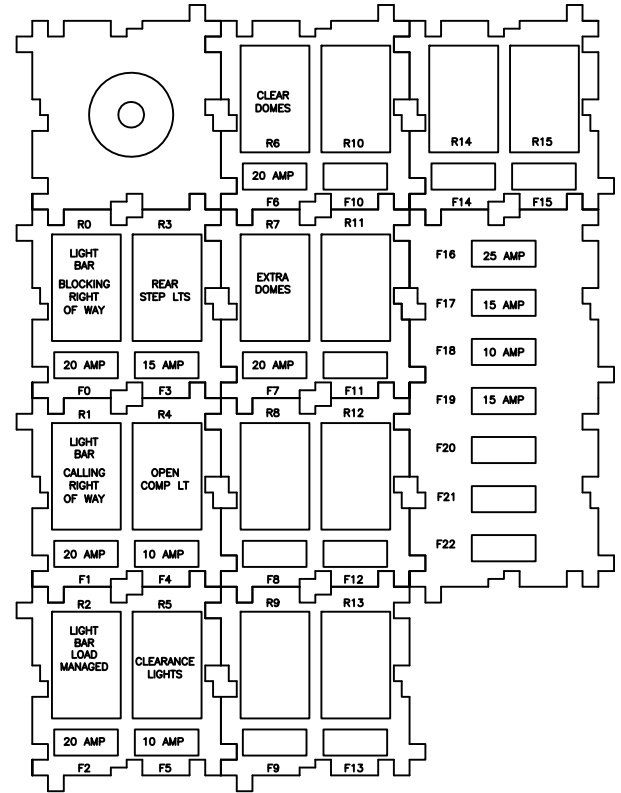

BASIC PANEL AND FUSE/BREAKER VALUES SHOWN. OPTIONS WILL DRIVE VARIATION.

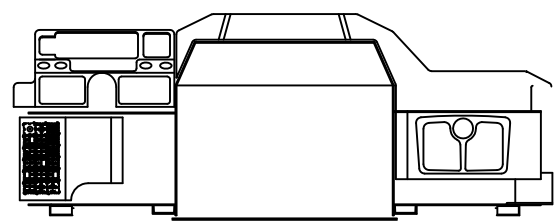
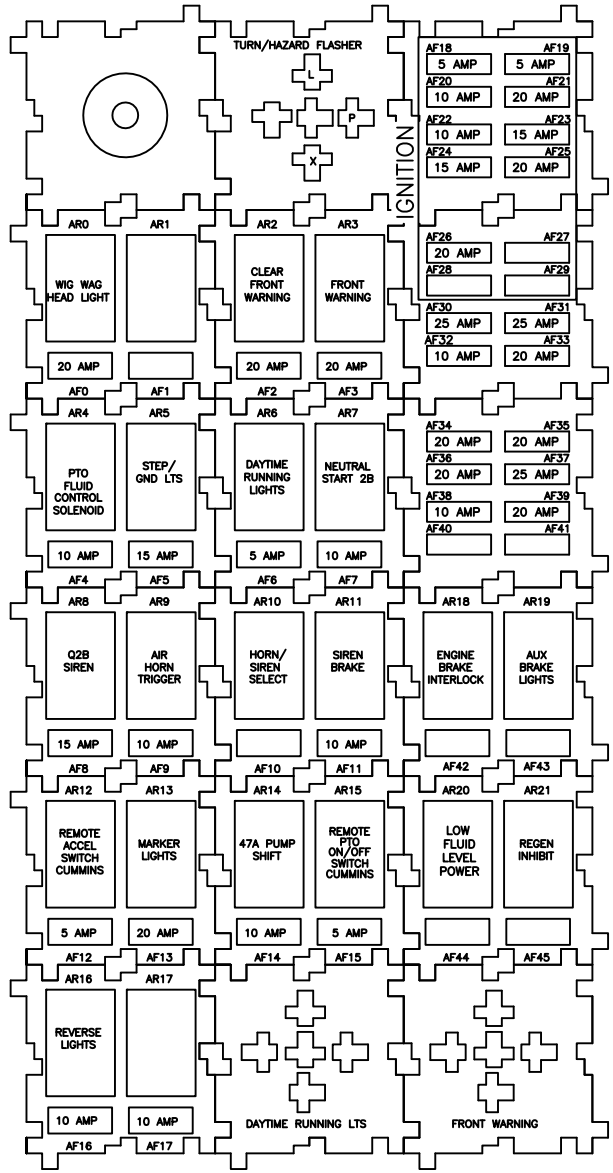

- AF0 HEADLIGHTS
- AF1
- AF2 CLEAR FRONT WARNING
- AF3 FRONT WARNING
- AF4 PTO SOLENOID
- AF5 FRONT STEP/GROUND LTS
- AF6 INSTRUMENTATION
- AF7 NEUTRAL POWER
- AF8 Q2B SIREN
- AF9 ELECTRIC HORN
- AF10
- AF11 SIREN BRAKE Q2B
- AF12 REMOTE ACCELERATOR
- AF13 TAIL/MARKER LTS
- AF14 MULTIPLEX/VDR
- AF15 REMOTE PTO
- AF16 REVERSE LIGHTS
- AF17 FUEL RE-PRIME
- AF18 TRANSMISSION TCM
- AF19 ENGINE ECM
- AF20 IGNITION - CHASSIS
- AF21 MOISTURE EJECTOR(S)
- AF22 IGNITION - CAB
- AF23 PUMP SHIFT/ENGINE BRAKE
- AF24 IGNITION - BODY BUILDER
- AF25 AIR DRYER
- AF26 AIR HORNS
- AF27
- AF28
- AF29
- AF30 BLOWER (AIR COND)
- AF31 BLOWER (AIR COND)
- AF32 WIPERS
- AF33 BRAKE LTS
- AF34 SPOT LTS/ENG MAINT LTS
- AF35 CIG LTR/12V OUTLET
- AF36 TURN/HAZARD
- AF37 BLOWER (HEATER)
- AF38 CAB TILT
- AF39 ELECTRONIC SIREN
- AF40
- AF41
- AF42
- AF43
- AF44
- AF45

BASIC PANEL AND FUSE/BREAKER VALUES SHOWN. OPTIONS WILL DRIVE VARIATION.

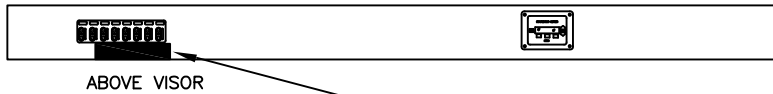

- F0 LIGHTBAR BRW
- F1 LIGHTBAR CRW
- F2 LIGHTBAR LOAD MANAGED
- F3 REAR STEP/GROUND LIGHTS
- F4 OPEN COMPARTMENT LIGHT
- F5 CLEARANCE LIGHTS
- F6 CLEAR DOME LIGHTS STANARD
- F7 EXTRA CLEAR DOMES
- F8 FUSE FOR RELAY R8
- F9 FUSE FOR RELAY R9
- F10 FUSE FOR RELAY R10
- F11 FUSE FOR RELAY R11
- F12 FUSE FOR RELAY R12
- F13 FUSE FOR RELAY R13
- F14 FUSE FOR RELAY R14
- F15 FUSE FOR RELAY R15
- F16 ROOF TOP A/C CONDENSOR
- F17 RED DOME LIGHTS
- F18 OVERHEAD MUX MODULES
- F19 OVERHEAD SPOT LIGHTS
- F20 OVERHEAD SIREN (OR SPARE)
- F21 STEREO (OR SPARE)
- F22 HEATER

BASIC PANEL AND FUSE/BREAKER VALUES SHOWN. OPTIONS WILL DRIVE VARIATION.

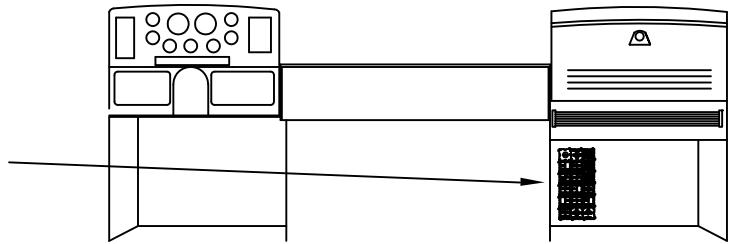
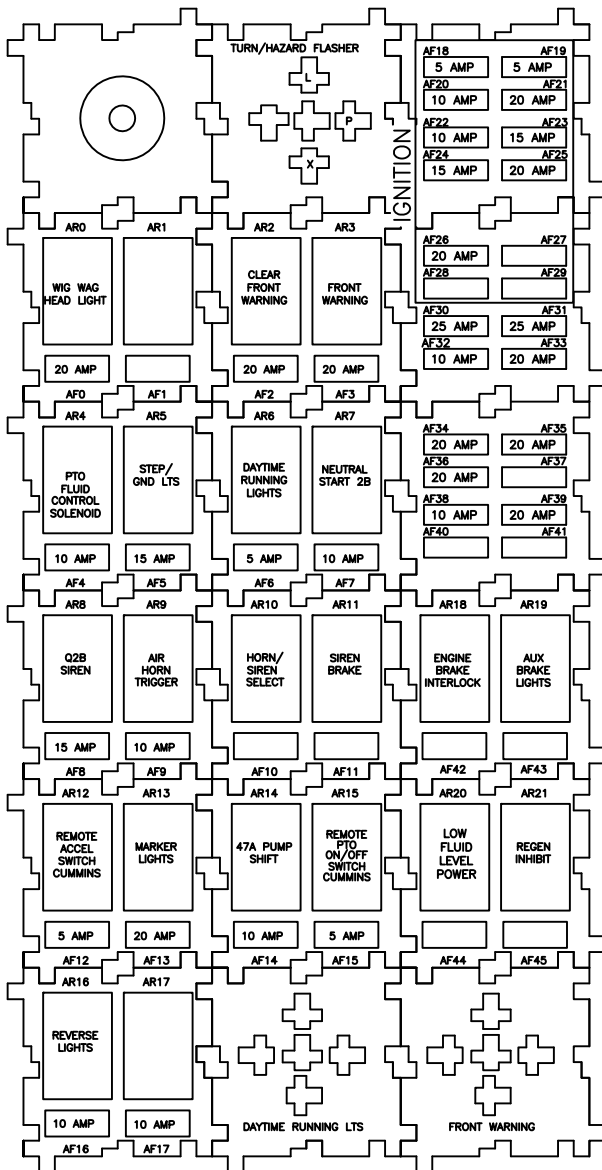
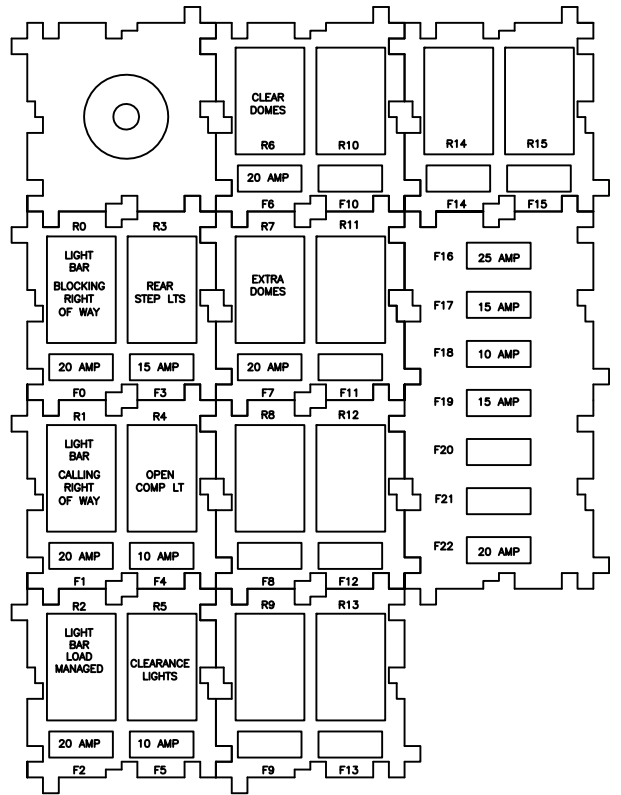

- AF0 HEADLIGHTS
- AF1
- AF2 CLEAR FRONT WARNING
- AF3 FRONT WARNING
- AF4 PTO SOLENOID
- AF5 FRONT STEP/GROUND LTS
- AF6 INSTRUMENTATION
- AF7 NEUTRAL POWER
- AF8 Q2B SIREN
- AF9 ELECTRIC HORN
- AF10
- AF11 SIREN BRAKE Q2B
- AF12 REMOTE ACCELERATOR
- AF13 TAIL/MARKER LTS
- AF14 MULTIPLEX/VDR
- AF15 REMOTE PTO
- AF16 REVERSE LIGHTS
- AF17 FUEL RE-PRIME
- AF18 TRANSMISSION TCM
- AF19 ENGINE ECM
- AF20 IGNITION - CHASSIS
- AF21 MOISTURE EJECTOR(S)
- AF22 IGNITION - CAB
- AF23 PUMP SHIFT/ENGINE BRAKE
- AF24 IGNITION - BODY BUILDER
- AF25 AIR DRYER
- AF26 AIR HORNS
- AF27
- AF28
- AF29
- AF30 BLOWER (AIR COND)
- AF31 BLOWER (AIR COND)
- AF32 WIPERS
- AF33 BRAKE LTS
- AF34 SPOT LTS/ENG MAINT LTS
- AF35 CIG LTR/12V OUTLET
- AF36 TURN/HAZARD
- AF37
- AF38 CAB TILT
- AF39 ELECTRONIC SIREN
- AF40
- AF41
- AF42
- AF43
- AF44
- AF45

BASIC PANEL AND FUSE/BREAKER VALUES SHOWN. OPTIONS WILL DRIVE VARIATION.

FUSE/RELAY PANELS

SPECTR (CLASSIC/NON-MULTIPLEXED)

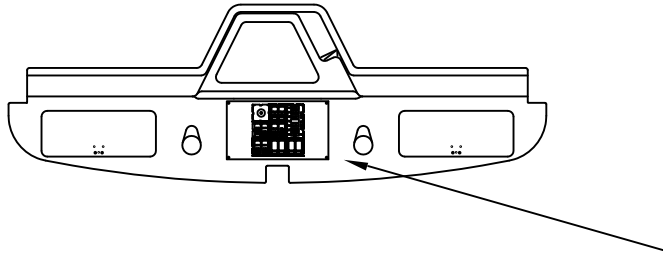

- | | |
|----------------------|------------------------|
| F1 SPARE | F10 FUSE FOR R10 |
| F2 SPARE | F11 FUSE FOR R11 |
| F3 SPARE | F12 FUSE FOR R12 |
| F4 LT BAR BRW | F13 SIREN/PA |
| F5 DOME LIGHTS | F14 SPOT LIGHTS |
| F6 EXTRA DOME LIGHTS | F15 A/C CONDENSER FANS |
| F7 LT BAR CRW | F16 SPARE |
| F8 LT BAR BRW | F17 RED DOME LIGHTS |
| F9 FUSE FOR R9 | F18 AM/FM STEREO |

BASIC PANEL AND FUSE/BREAKER VALUES SHOWN.
OPTIONS WILL DRIVE VARIATION.

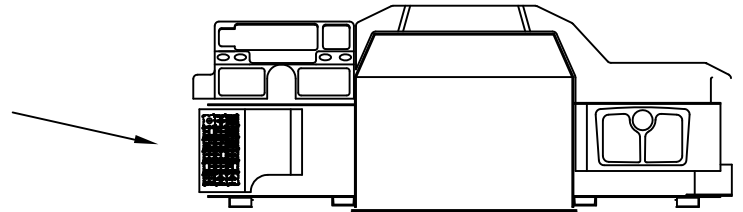
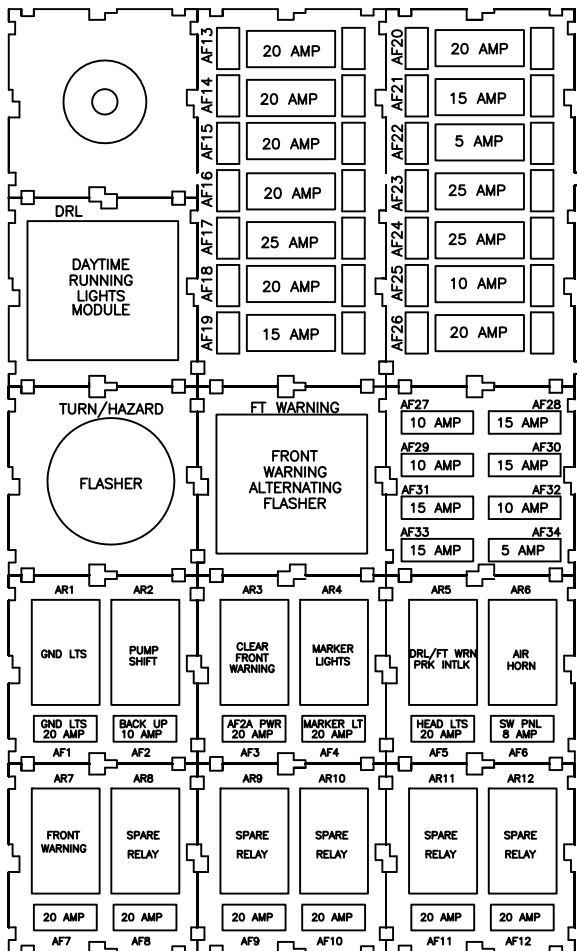
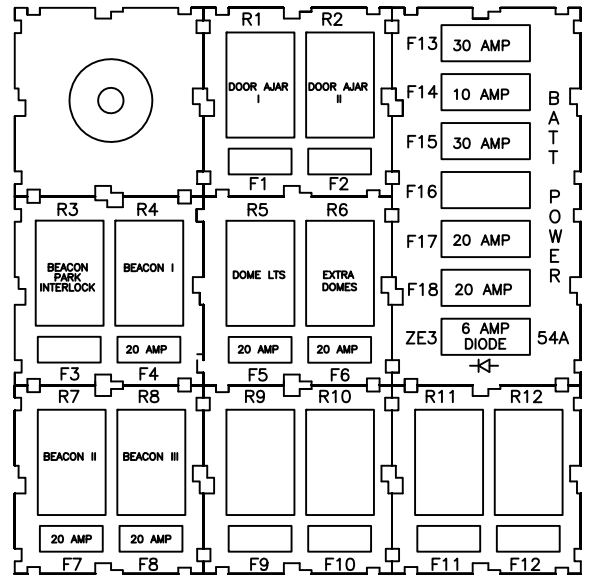

- | | |
|--------------------------------|-------------------------------|
| AF1 GROUND LIGHTS | AF18 TURN/HAZARD |
| AF2 BACK UP LIGHTS/ALARM | AF19 PARK INTERLOCK |
| AF3 ADDITIONAL FRONT WARNING | AF20 REPRIME PUMP |
| AF4 MARKER LIGHTS POWER | AF21 LIGHTER/POWER PORT |
| AF5 HEAD LIGHTS | AF22 INSTRUMENTS |
| AF6 SWITCH PANEL POWER | AF23 A/C BLOWER 1 |
| AF7 FUSE FOR AR7 | AF24 A/C BLOWER 2 |
| AF8 FUSE FOR AR8 | AF25 CAB TILT/VDR |
| AF9 FUSE FOR AR9 | AF26 HORN |
| AF10 FUSE FOR AR10 | AF27 PUMP SHIFT/ENG BRK |
| AF11 FUSE FOR AR11 | AF28 HEATED MOISTURE EJECTORS |
| AF12 FUSE FOR AR12 | AF29 BODY BUILDERS IGNITION |
| AF13 SPOT, ENGINE MAINT LIGHTS | AF30 AIR DRYER |
| AF14 SIREN, PA | AF31 IGNITION (CAB) |
| AF15 STOP LIGHTS | AF32 AIR HORNS |
| AF16 WIPERS | AF33 IGNITION (CHASSIS) |
| AF17 HEATER | AF34 ENG ECM |

BASIC PANEL AND FUSE/BREAKER VALUES SHOWN.
OPTIONS WILL DRIVE VARIATION.

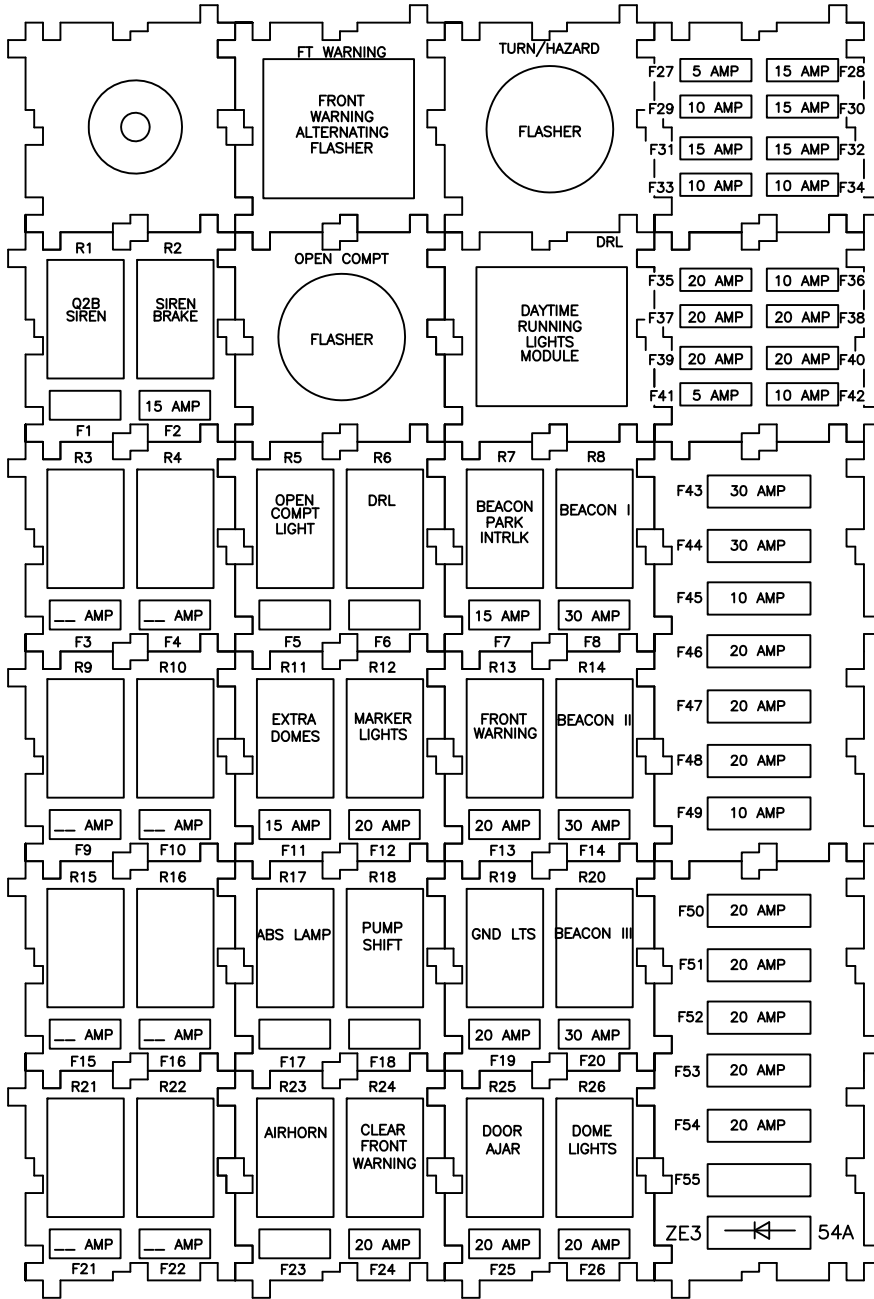

- F1
- F2 Q2B SIREN
- F3
- F4
- F5
- F6
- F7 POWER PORT/CIG LTR
- F8 LT BAR BRW
- F9
- F10
- F11 EXTRA DOME LIGHTS
- F12 MARKER LIGHTS
- F13 FRONT WARNING
- F14 LT BAR CRW
- F15
- F16
- F17
- F18
- F19 GROUND LIGHTS
- F20 LT BAR BRW
- F21
- F22
- F23
- F24 CLEAR FRONT WARNING
- F25 DOME LIGHTS
- F26 STEREO
- F27 ENGINE ECM
- F28 HEATED MOISTURE EJECTORS
- F29 PUMP SHIFT/ENGINE BRK
- F30 IGNITION (CHASSIS)
- F31 AIR DRYER
- F32 IGNITION (CAB)
- F33 AIR HORNS
- F34 IGNITION (BODY BUILDER)
- F35 ENGINE MAINT.LT/SPOT LIGHT
- F36 CAB TILT INTERLOCK
- F37 HEADLIGHTS
- F38 RED DOME LIGHTS
- F39 HORN
- F40 TURN/HAZARD
- F41 INSTRUMENTATION
- F42 REVERSE LIGHTS
- F43 A/C BLOWER 1
- F44 A/C BLOWER 2
- F45 SWITCH PANEL
- F46 WIPERS
- F47 PARK INTERLOCK
- F48 FUEL REPRIME
- F49 VDR (VEHICLE DATA RECORDER)
- F50 A/C CONDENSER (SINGLE)
- F51 A/C CONDENSER (DUAL)
- F52 SIREN/PA
- F53 STOP LTS
- F54 HEATER
- F55
- F56 DOOR AJAR DIODE

BASIC PANEL AND FUSE/BREAKER VALUES SHOWN.
 OPTIONS WILL DRIVE VARIATION.

Many HME Cab-Chassis are now multiplexed. Simply put this means strategically placed electronic modules linked by a data bus receive input and provide individual circuit control. The processors (instead of complex arrangements of relays) handle circuit logic and wire harnesses are reduced in size and complexity.

In addition to the inherent dependability the system also offers the benefit of on-board diagnostics should a failure occur.

You can quickly determine if your apparatus is multiplexed by the presence of this display in the cab.

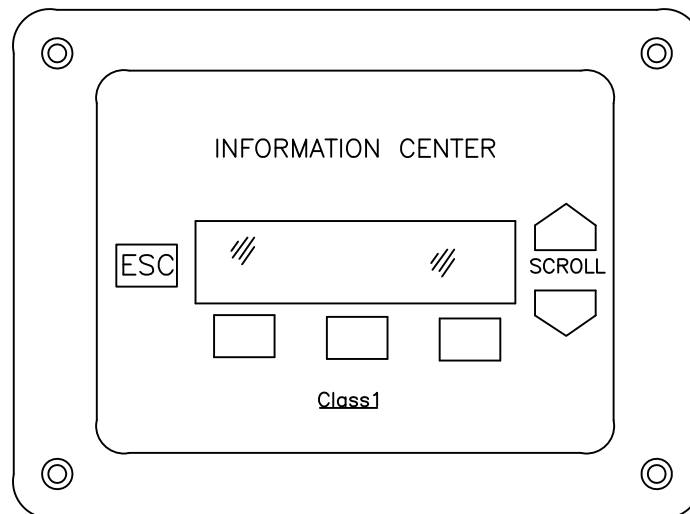

The multiplex data bus is a private bus based on the same architecture as your typical SAE J1939 Lite Power Train data bus. It is a twisted pair terminated at each end with 120 ohm resistors. All components are connected in parallel.

The components in the system operate in a "Master-Slave" relationship with the System Manager holding the bulk of the control logic programming. "Slave" modules may be any arrangement of Inpu/Output, Power Distribution, Display, or other.

Being custom vehicles component selection, location, and data bus routing may vary somewhat from one vehicle to the next but will follow one these two basic formats.

SPECTR CHASSIS

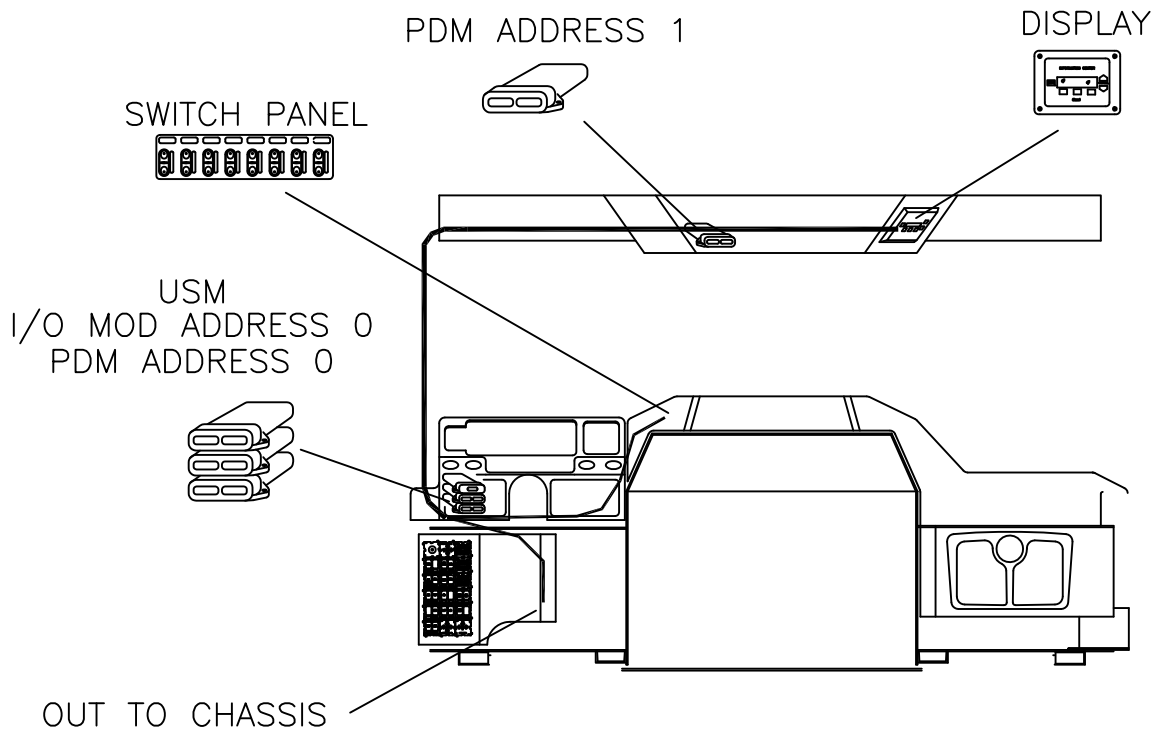

1871 SFO/VC/W CHASSIS

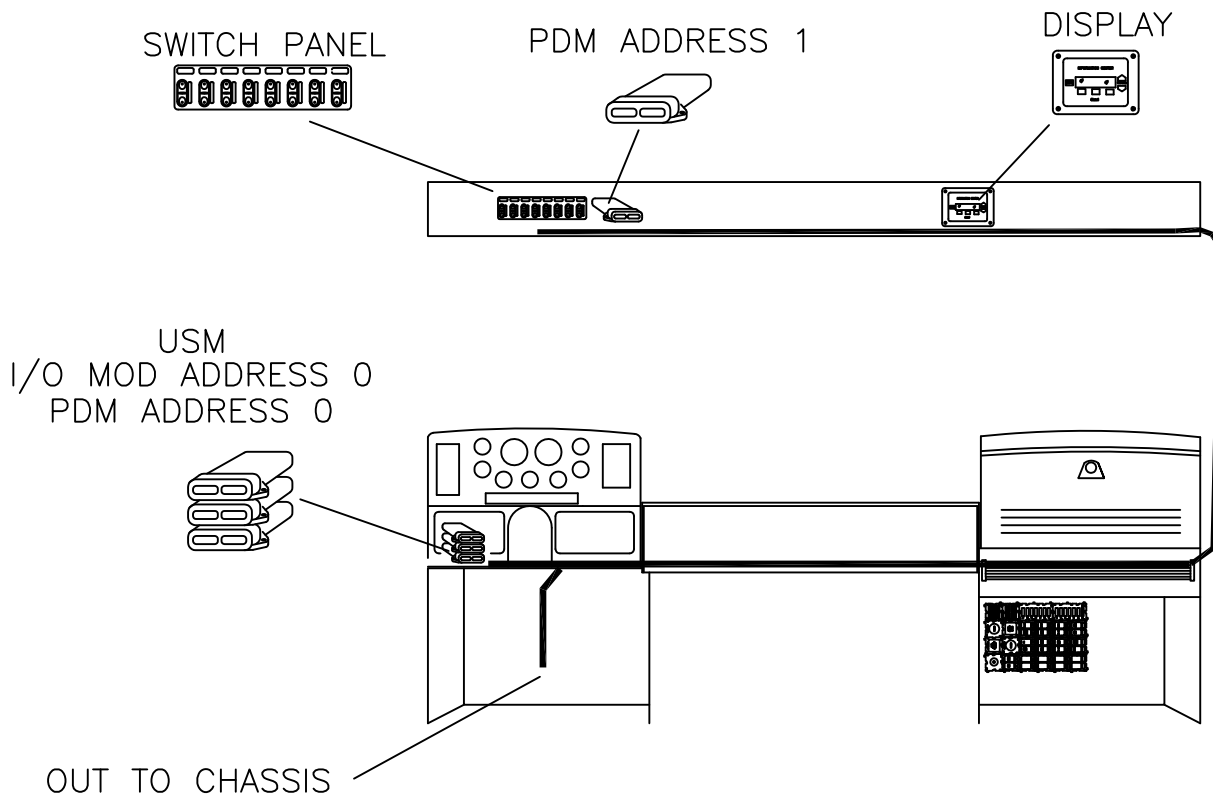

Faults that occur within the multiplexing system will be indicated by the illumination of the red MUX ERROR lamp in the instrument panel. A fault code will also be logged.

Diagnostic features can be accessed through the display with a pass code and include system fault identification, input/output monitoring, and input/output control capabilities.

WARNING:

Actions taken in the Pass code accessed menus can influence the vehicles networked systems. Some actions may cause operational malfunction leading to equipment or property damage, physical injury, or death.

ONLY QUALIFIED PERSONNEL WITH A FULL UNDERSTANDING OF THE POTENTIAL OF THEIR ACTIONS SHOULD ACCESS THESE MENUS.

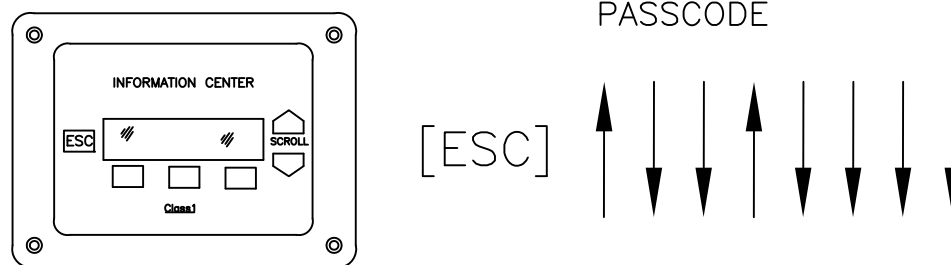

Enter the passcode using the UP/DOWN scroll keys after you ensure you are at the main menu by pressing the ESC key a few times. Once entered the text "PASSWORD ACCEPTED" will be displayed and full access to the diagnostic menus will be granted. There is a map of these menus on the following page with the path to the fault code branch highlighted.

Exit to the main menu and cycle power to the system (VIA the cab battery switch) to restore normal function when you are finished.

DIAGNOSTIC MENU TREE

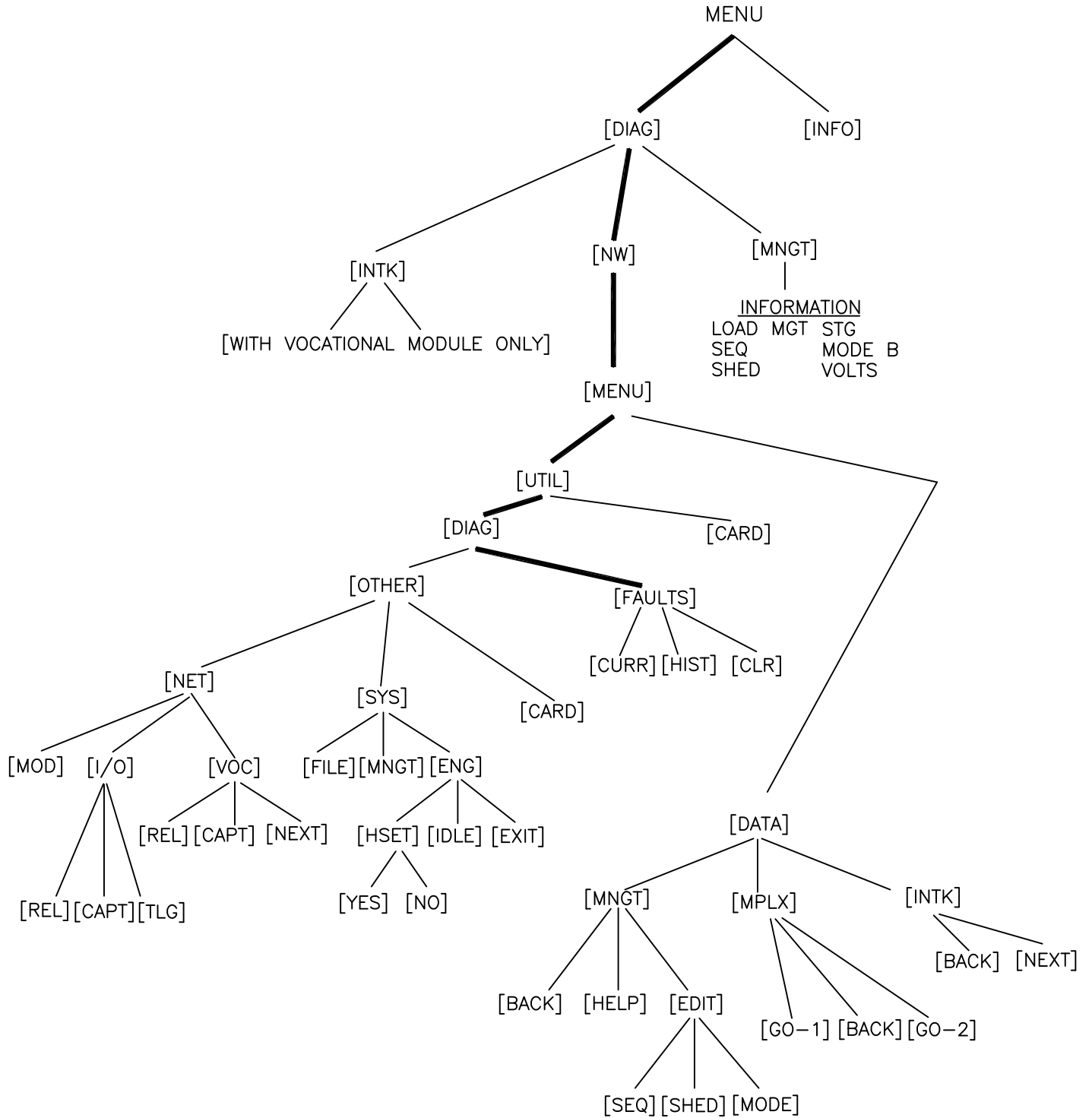

In addition to the features described on the previous pages many of the system modules incorporate diagnostic indicators.

INDICATOR LOCATION BY MODULE TYPE

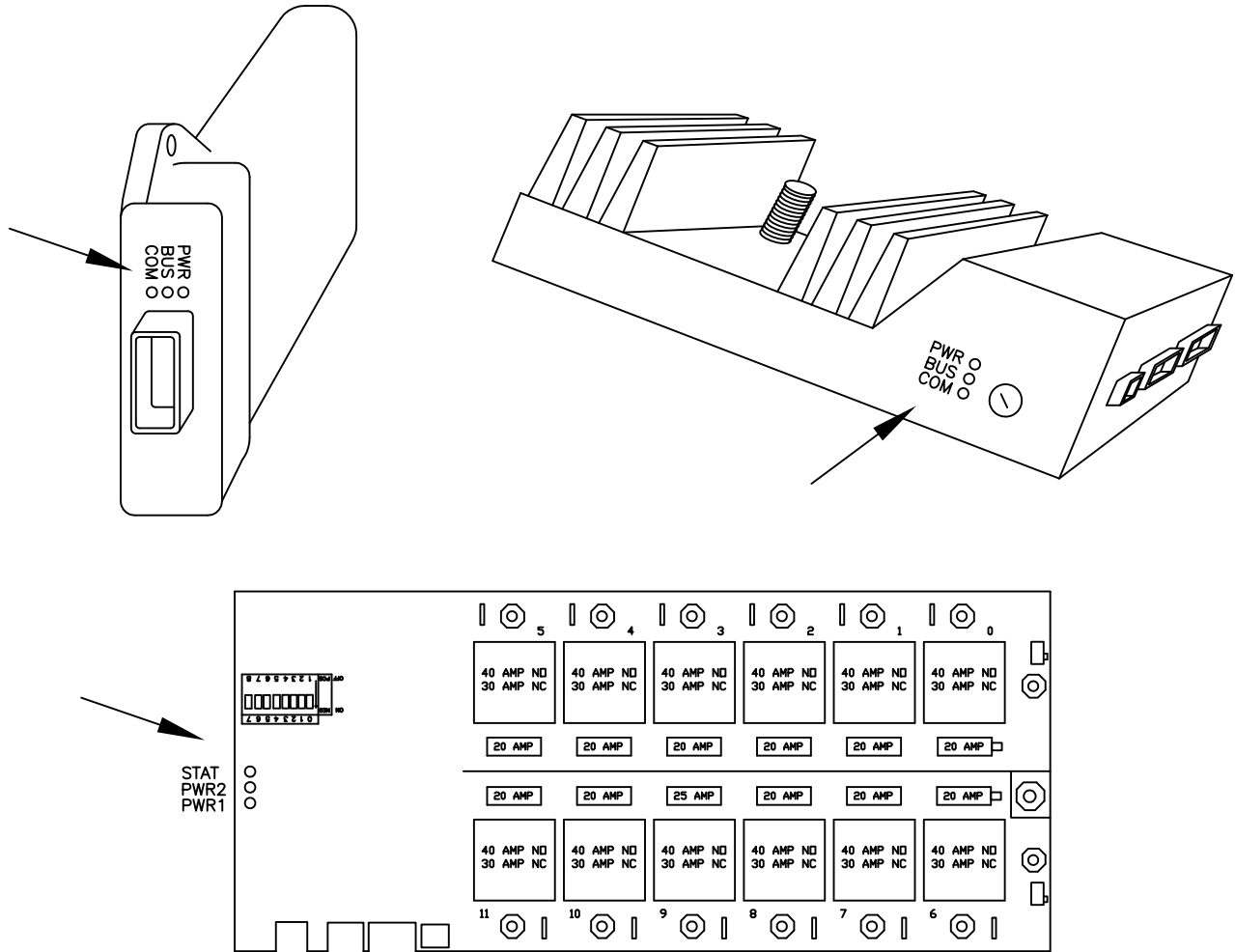

These indicators provide pwr and communication information as follows;

INDICATOR	STATUS	DESCRIPTION
PWR (or PWR1)	OFF	NO POWER TO MODULE
	ON	OK
BUS (OR PWR2)	OFF	NO POWER TO THE OUTPUT DRIVER BUS BAR.
	ON	OK
COM (OR STAT)	OFF	IMPROPER CAN BUS CONNECTION
	FLASHING	DEVICE NOT CONFIGURED, IMPROPERLY ADDRESSED, OR NOT ABLE TO COMMUNICATE WITH SYSTEM MANAGER
	ON	OK

The switch panel itself is a module on the bus. It's back lighting can be considered the "PWR" indicator, it does not have an output driver bus, and the "Class-1" logo in the face of the panel will act as the "COM" or "STAT" indicator, flashing if it is not properly configured or not in communication with the System Manager.

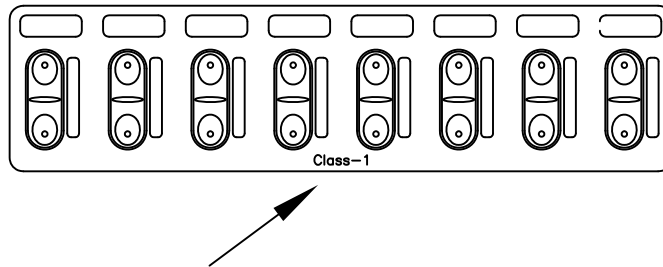

The display is also a module on the bus with no diagnostic indicators. It also has no output driver bus and offers no indication as to whether or not it is properly connected to the CAN bus or is in communication with the USM other than that it will not display its commanded text, nor will it function in any menus that require interaction with the USM if it is not.

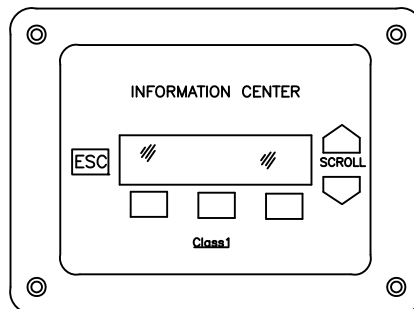

PRIMARY CONNECTIONS BY MODULE TYPE

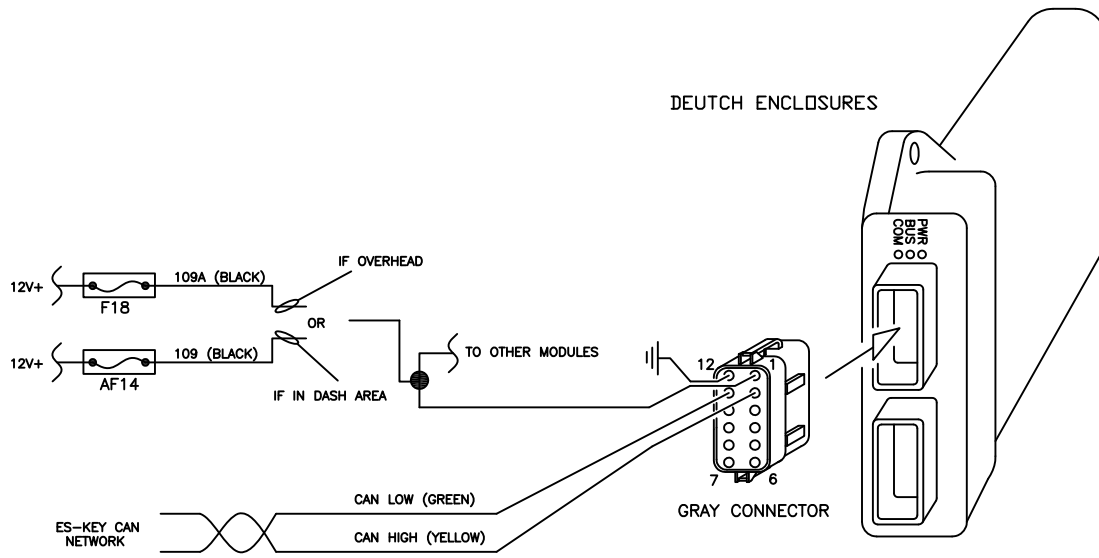

NOTE: SYSTEM MANAGER HAS ONLY ONE CONNECTOR

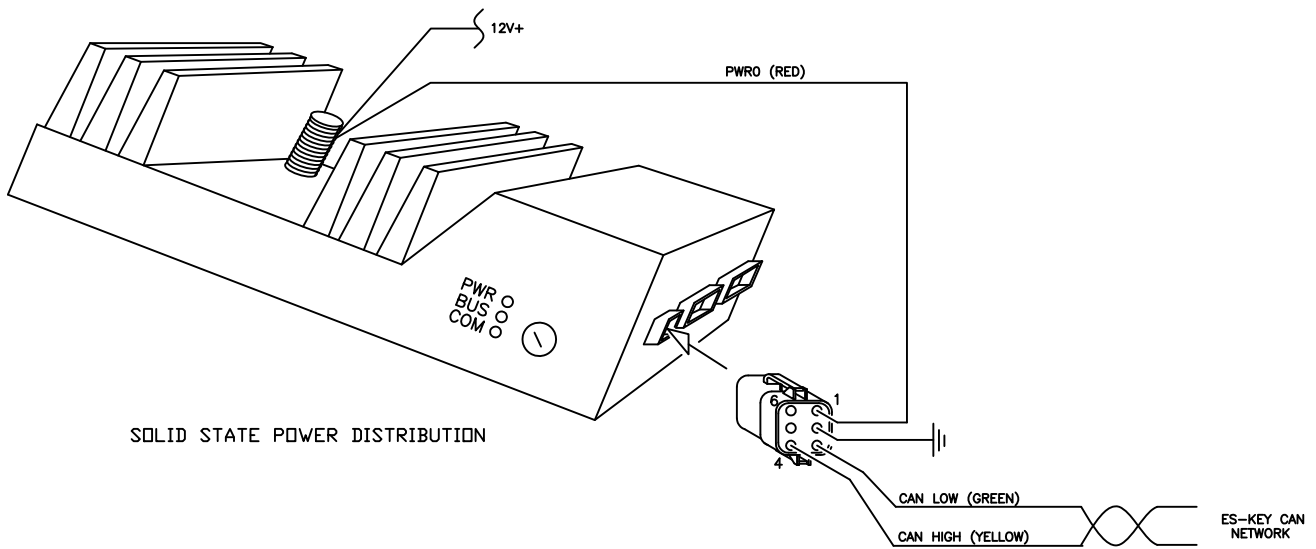

PRIMARY CONNECTIONS BY MODULE TYPE (CONT)

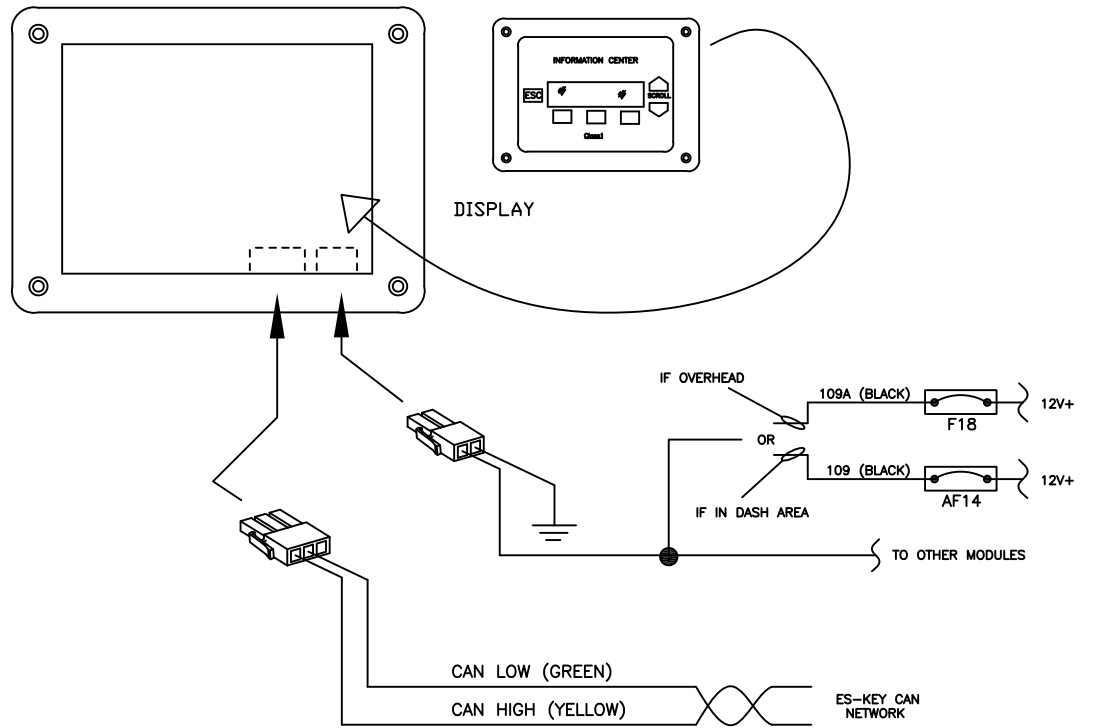
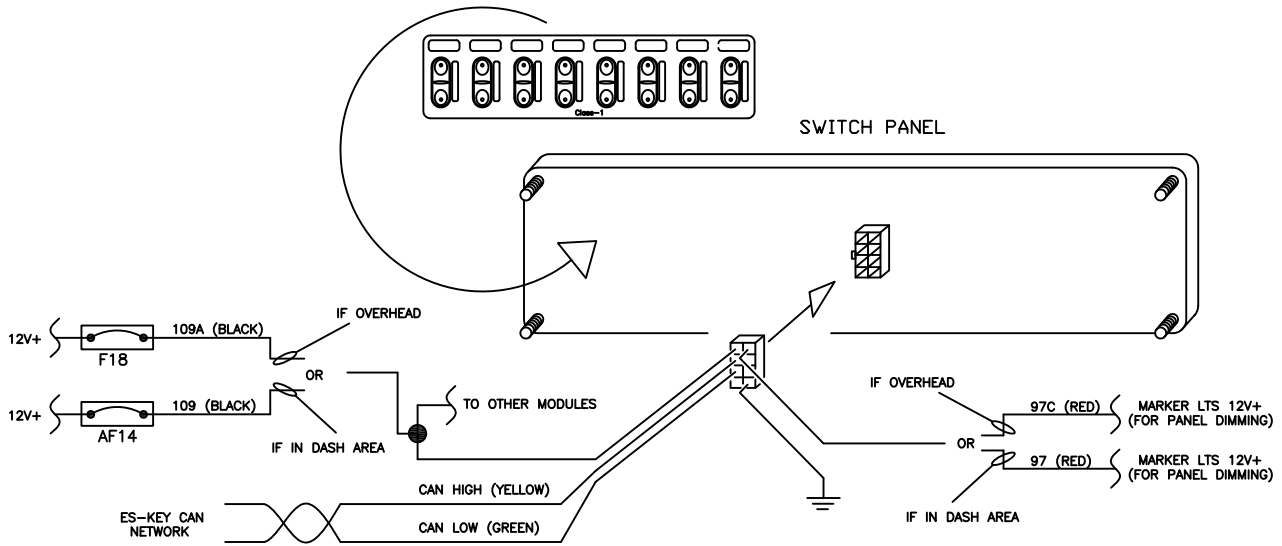

PRIMARY CONNECTIONS BY MODULE TYPE (CONT)

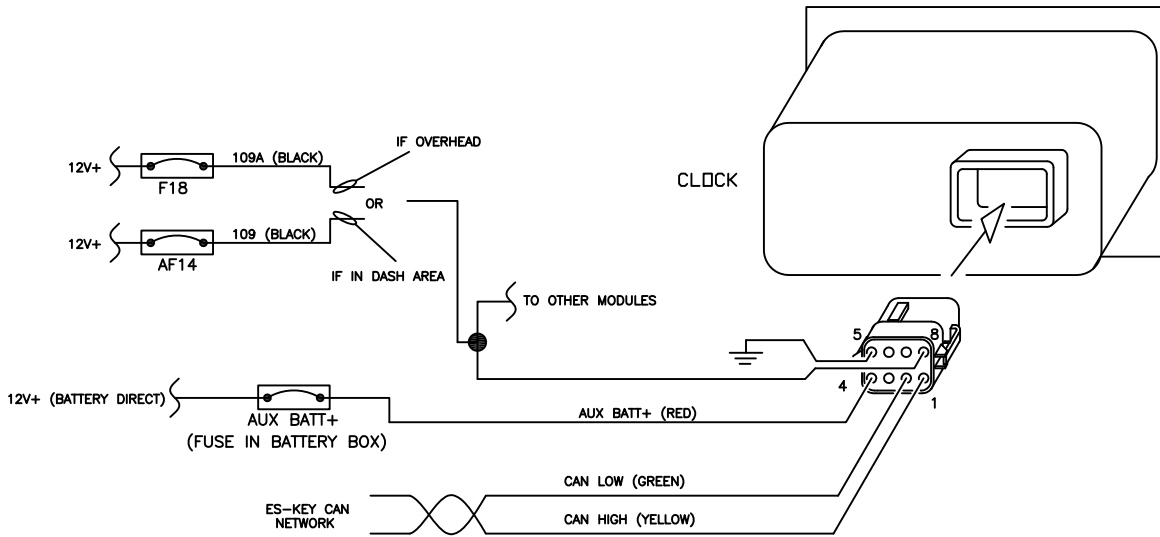
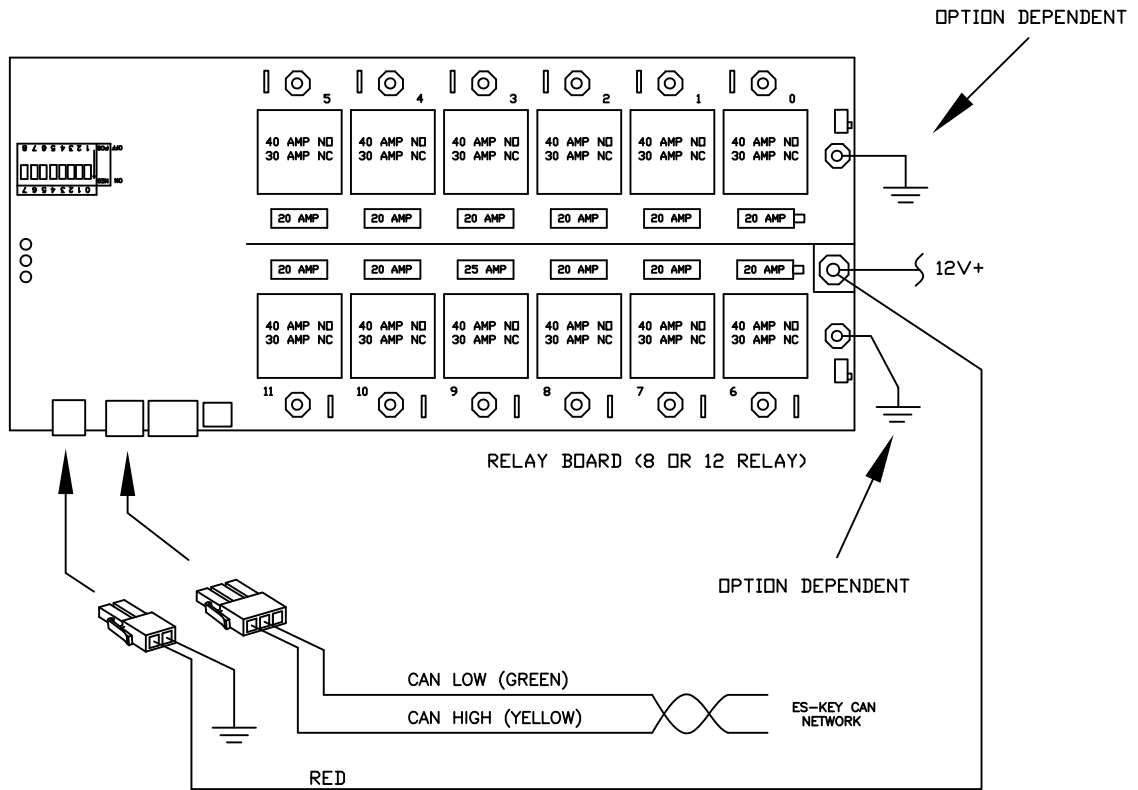

The "Gateway" interface connector is located beneath the drivers dash and provides access to the multiplexing system VIA laptop (software required) or modem (remote access).

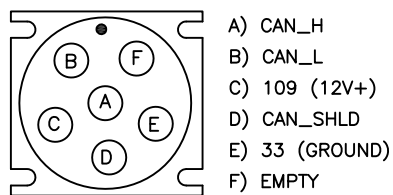
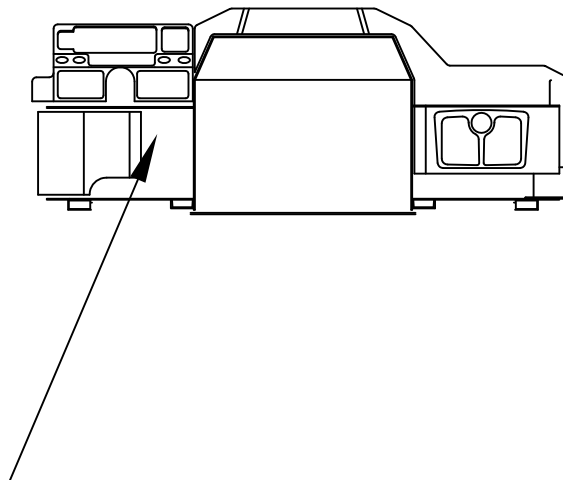

ES-KEY GATEWAY INTERFACE
(BENEATH DRIVERS DASH)

The Es-Key CAN bus is terminated at each end with a 120 ohm resistor between the High and Low (CAN_H & CAN_L) circuits in Deutsch 3 pin connectors.

The forward termination resistor will be located in the overhead in the vicinity of the overhead fuse/relay panel access opening.

The rear termination resistor will be located in the left rail just behind the cab on a chassis-cab, but may have been relocated into the body if the body builder incorporated the system into their build. Do not confuse this termination with that for the SAE J1939 CAN bus, which will also be located in the left rail but generally up under the cab. Continuity testing with the Gateway Connector may be necessary to differentiate.

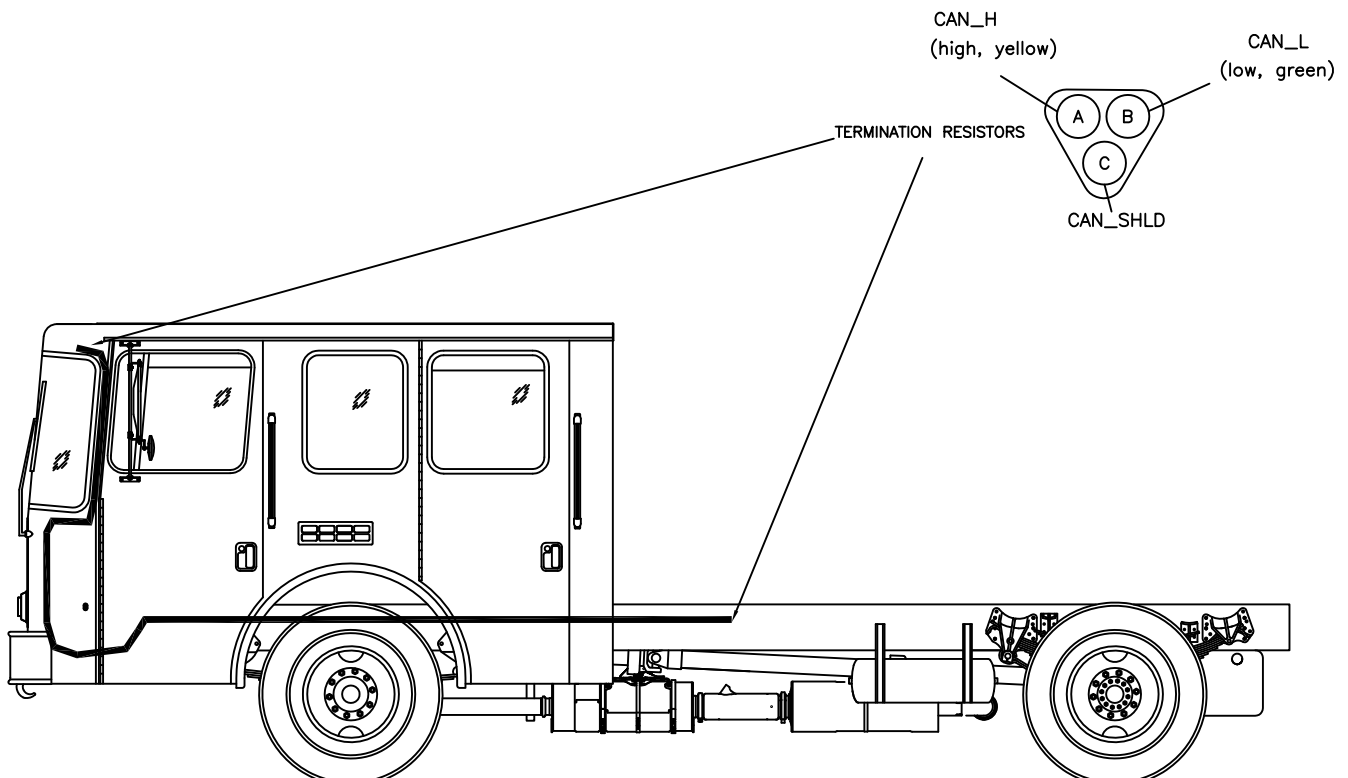

- 1) Approximate the location of the failure based on the "Device Offline" faults logged if possible.
- 2) A healthy Databus will typically measure (when active) about 2.4 Volts on the LOW circuit, and 2.6 on the HIGH. This measurement will vary slightly with bus loading and traffic, but generally not more than one half volt.
- 3) With a 120 ohm termination resistor at each end of the bus you should measure approximately 60 ohms between the HIGH and LOW circuits at any point on the bus.
- 4) There should be no appreciable continuity between either the HIGH or LOW circuits and the Shield or ground. (Typicaly about 3.8 Megaohms)
- 5) Taking the measurements outlined in 2, 3, & 4 at the Gateway connector can quickly establish the integrity of the main body of the bus over it's entire length, leaving only the individual legs in question.
- 6) An OPEN circuit in one leg of the data bus will interrupt communication with the device(s) on that leg only.
- 7) An OPEN circuit in the main trunk (or backbone) of the data bus will not only interrupt communication at the point of failure, it may effect communication on the remaining "intact" portion of the bus. This is due to the increased impedance caused by the lack of continuity with the termination resistor on the far side of the failure.
- 8) An OPEN circuit between two actively broadcasting devices will show healthy voltage measurements on either side of the fault. Continuity testing is the best approach for locating this type of failure.
- 9) A SHORT circuit at any point in the bus will effect the entire bus.
- 10) Not all short circuits are "SHORT TO GROUND".
- 11) Limit repetitive testing by working in a process of elimination and taking careful notes.

AREAS OF LIMITED ACCESS

If you have confirmed the source of a failure to be in a section of harness that is not readily accessible, do not try to dig for it. Instead, isolate that portion of the circuit and reconstruct it.

FAULT HISTORY

Once you have confirmed your repairs are complete clear the fault history.

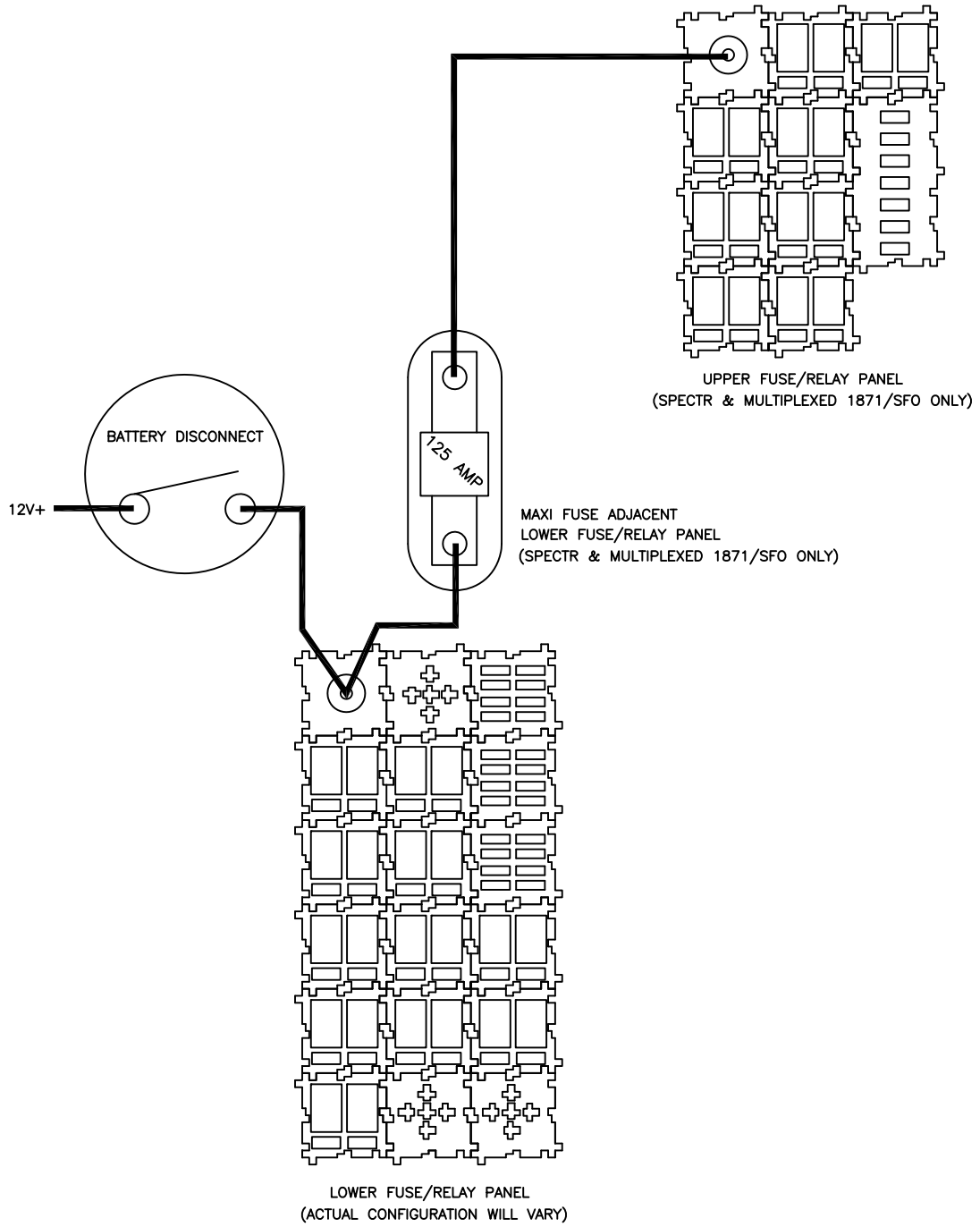

SCHEMATICS

IGNITION SWITCH/BUS
ALL MULTIPLEXED

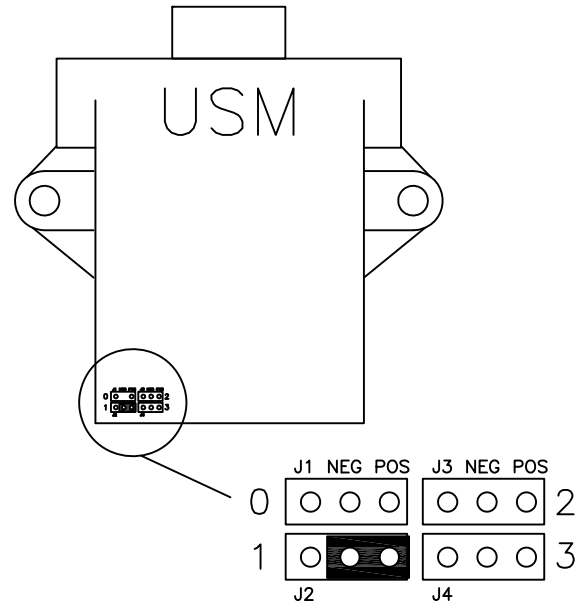
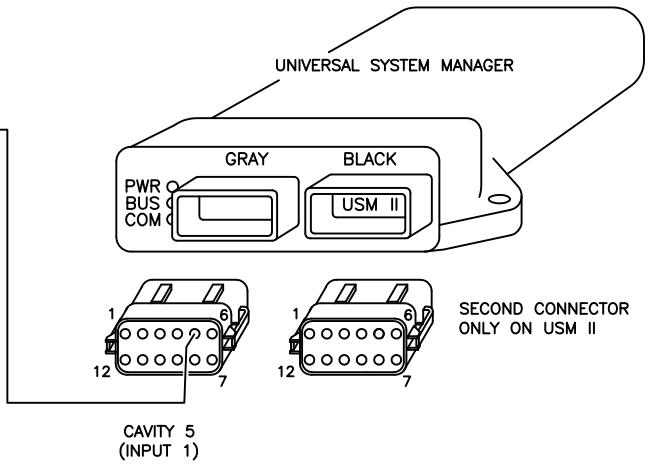
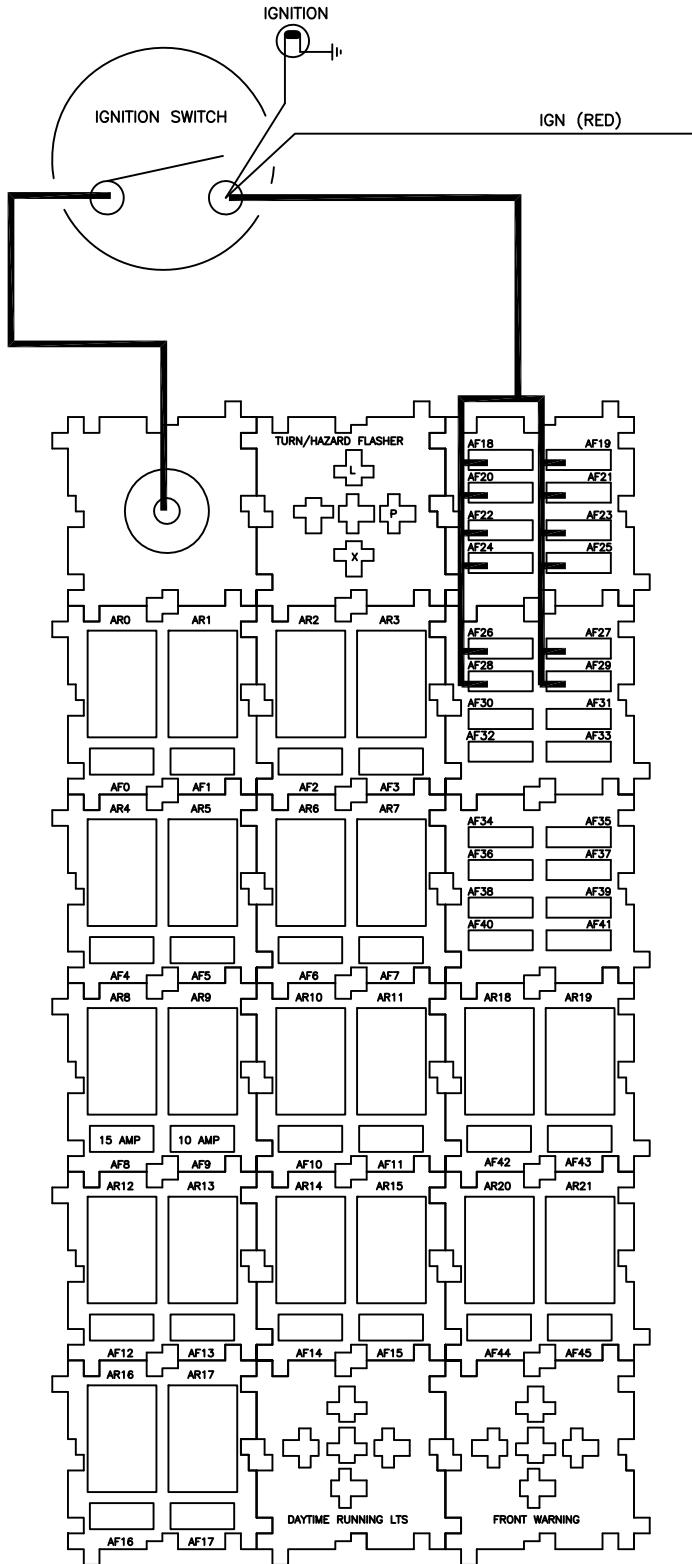

NOTE: JUMPER "J2" FOR INPUT 1
MUST BE SET TO POSITIVE

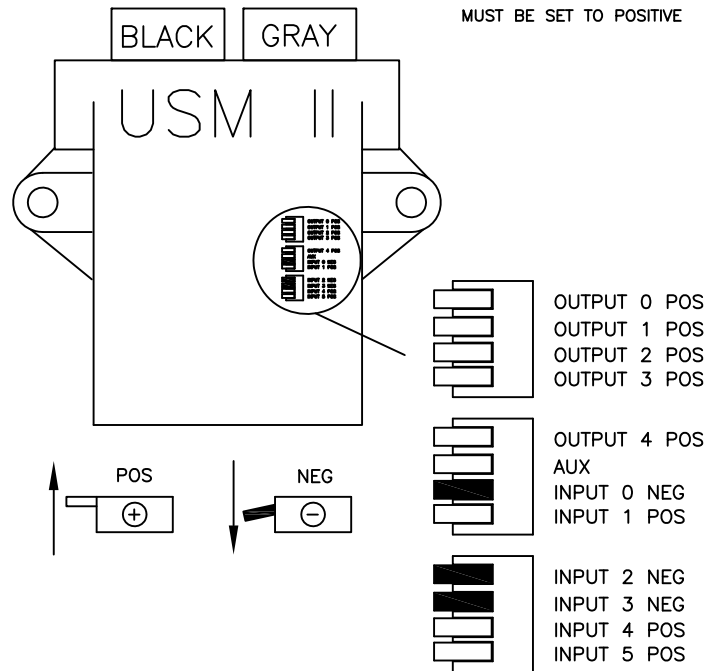

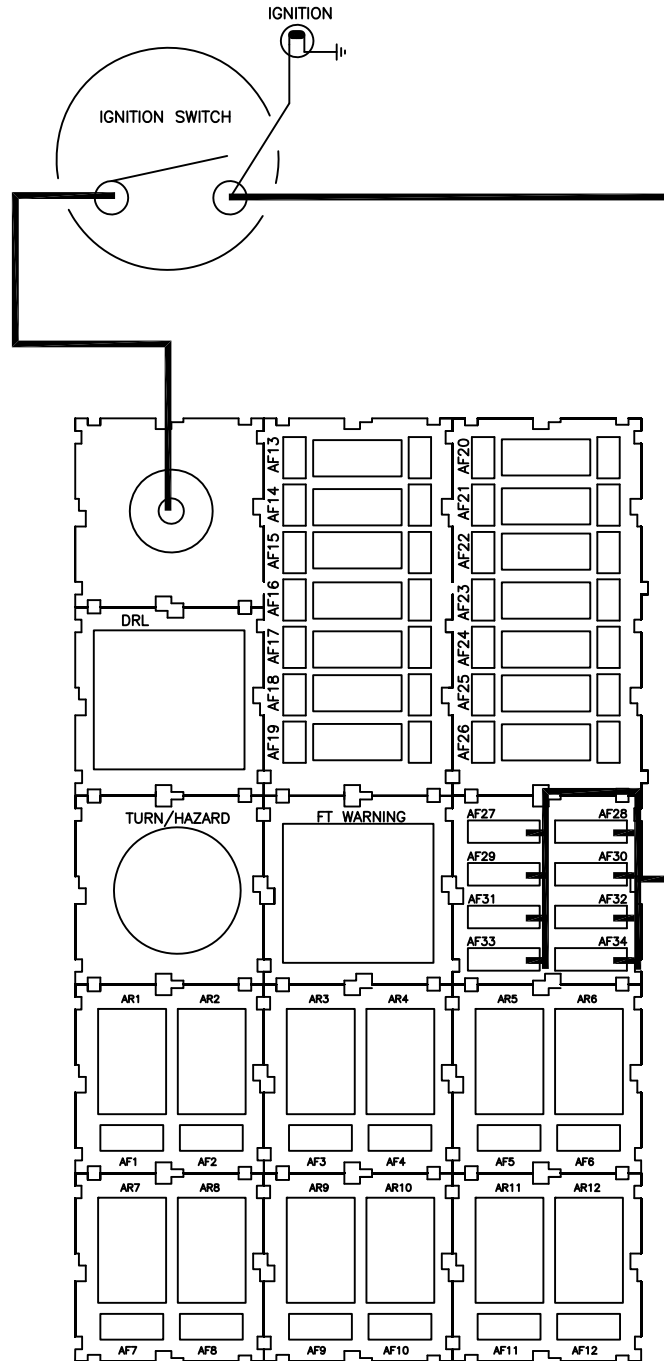

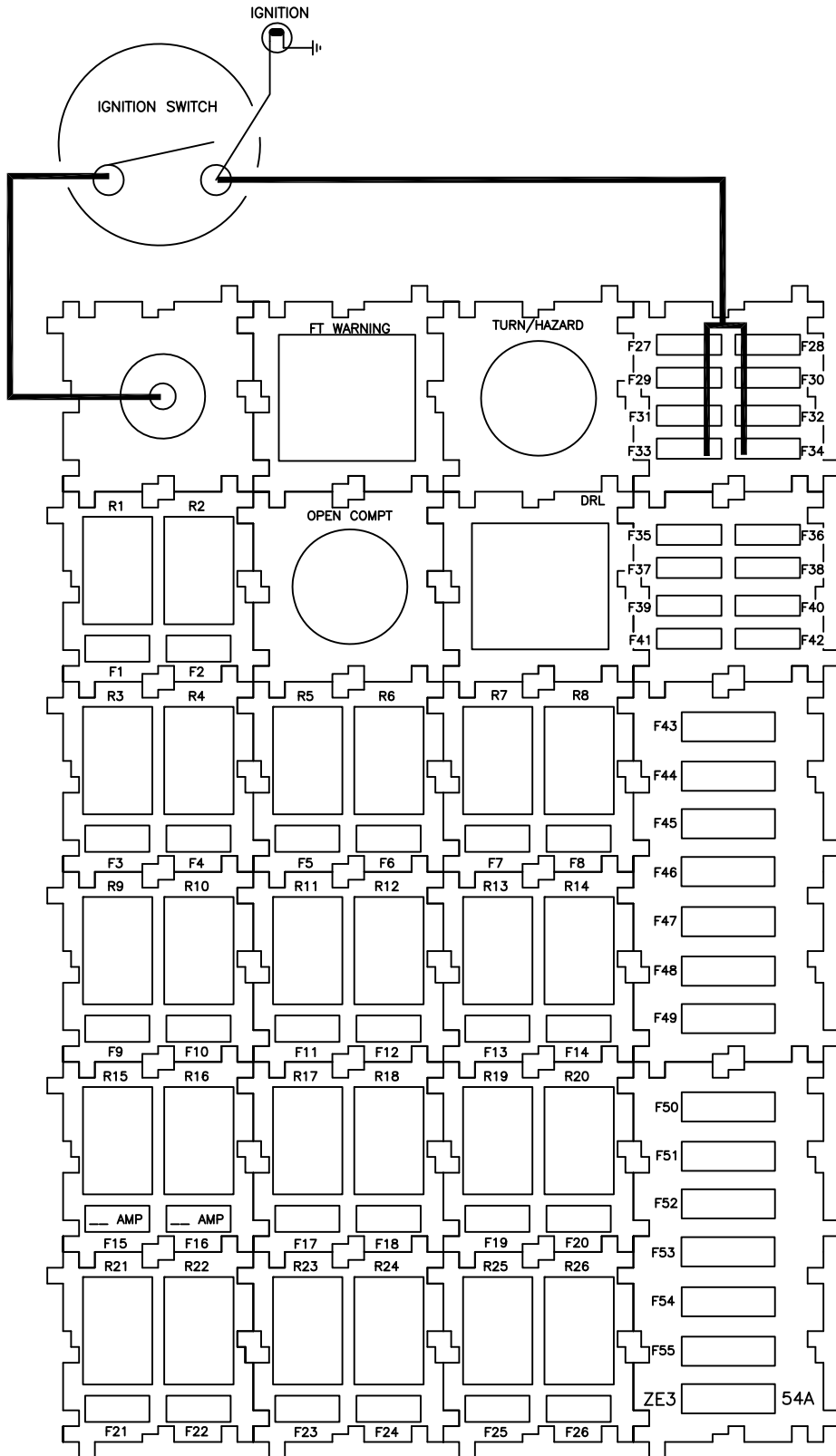

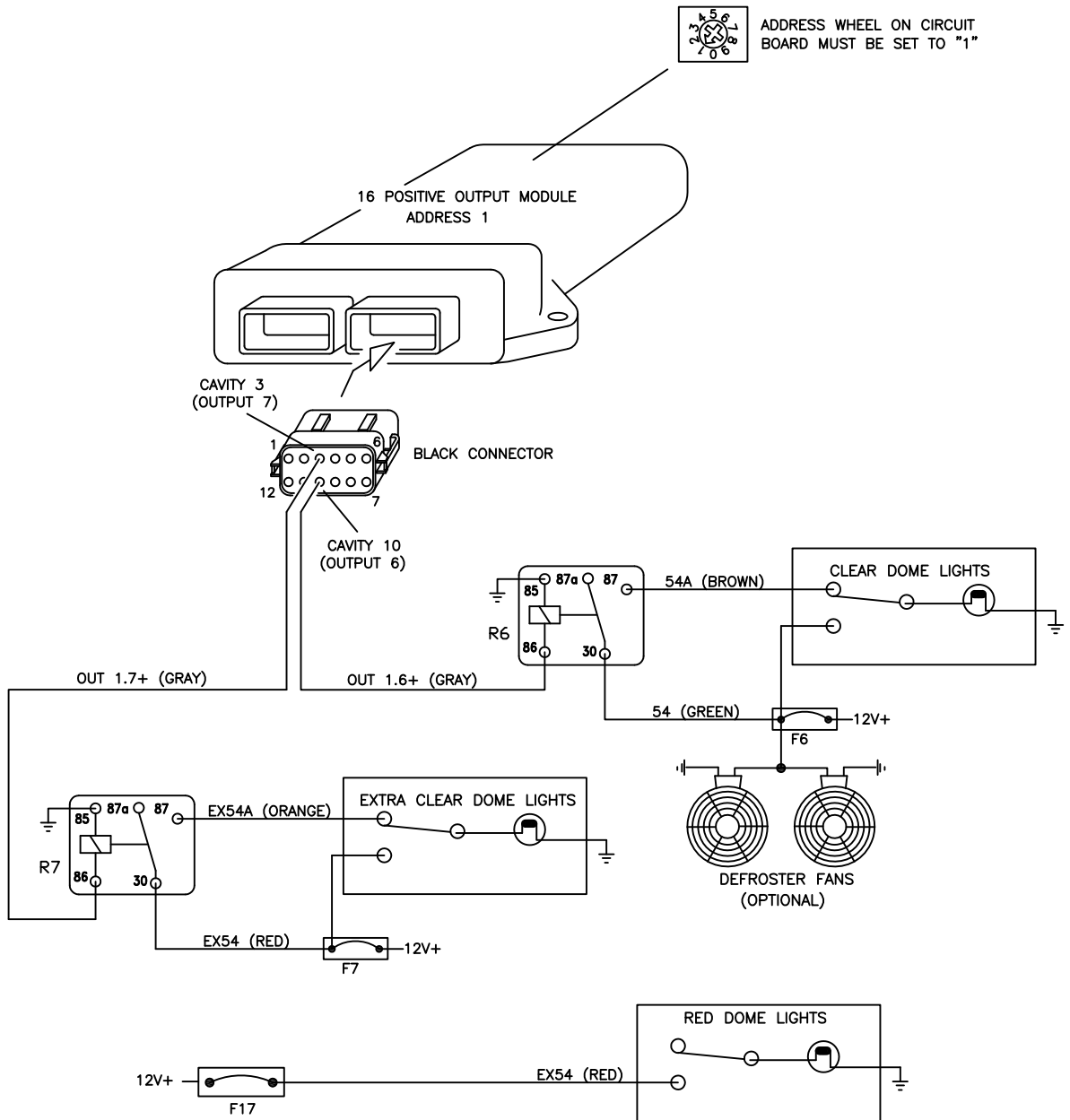

Automatic dome light activation is based on door switch status (see following page).

Components shown above are located in or near the overhead fuse/relay panel.

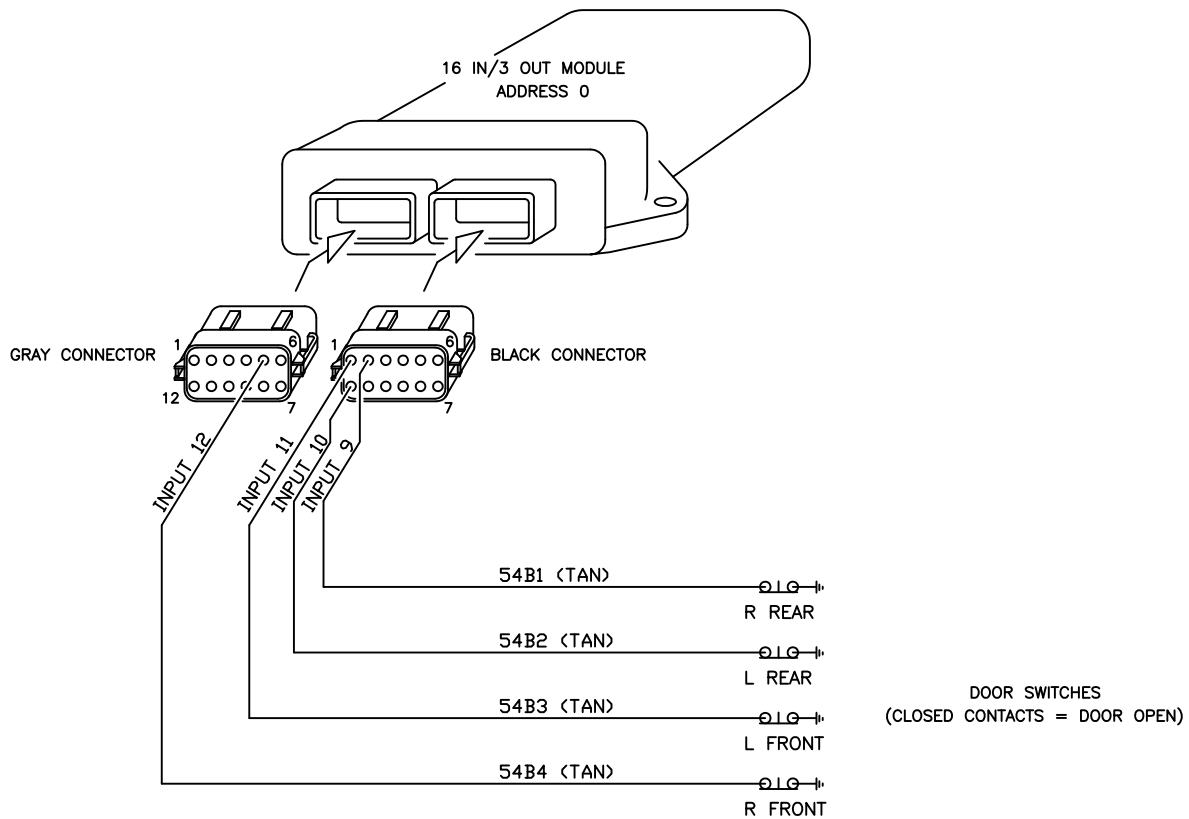
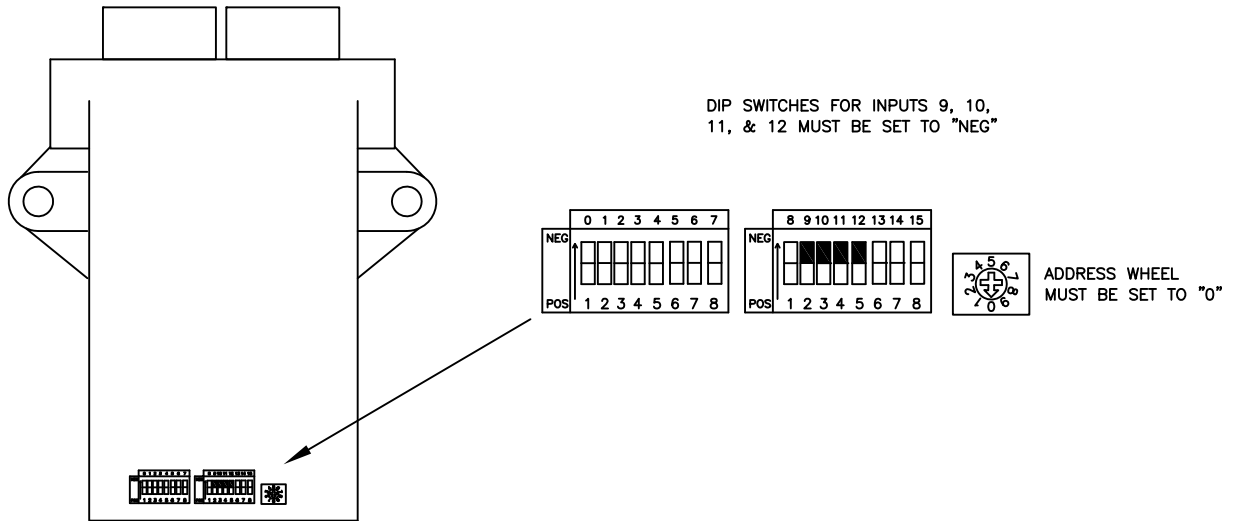

SCHEMATICS

INTERIOR LIGHTING
ALL NON-MULTIPLEXED

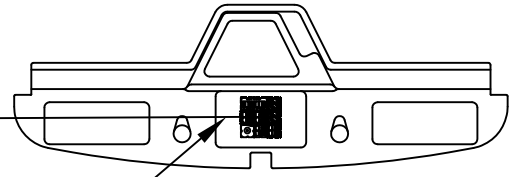
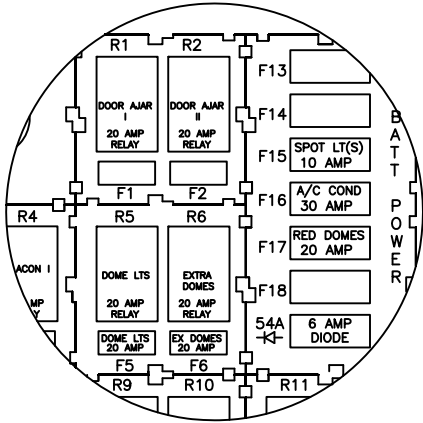

NOTE: OPEN COMPARTMENT WARNING LIGHT FLASHER (IF USED) IS IN-LINE, ATTACHED TO HARNESS NEAR PANEL

OVERHEAD FUSE PANEL (SPECTR)

SEE FOLLOWING PAGE FOR 1871/SFO FUSE PANEL COMPONENT LOCATIONS

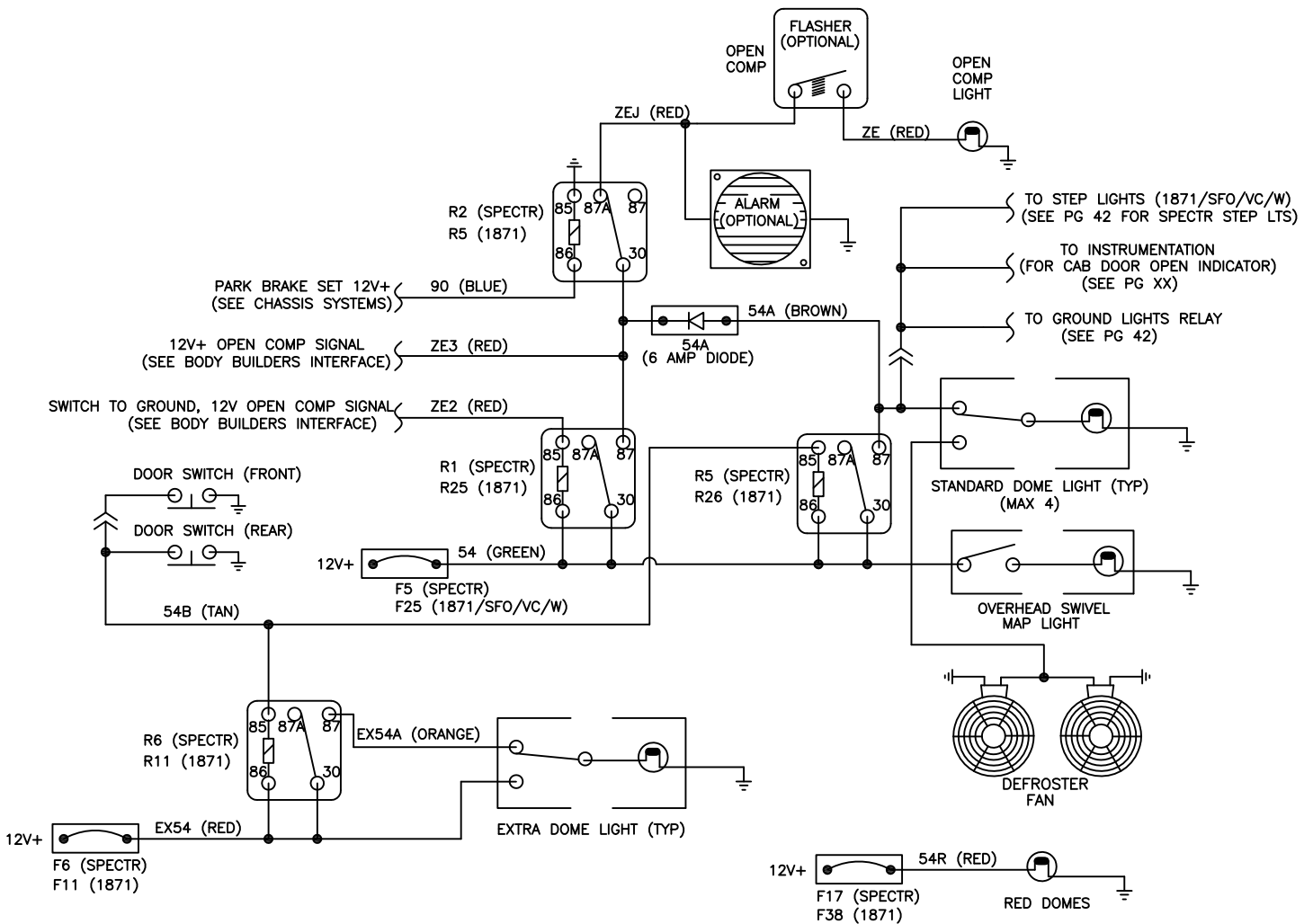

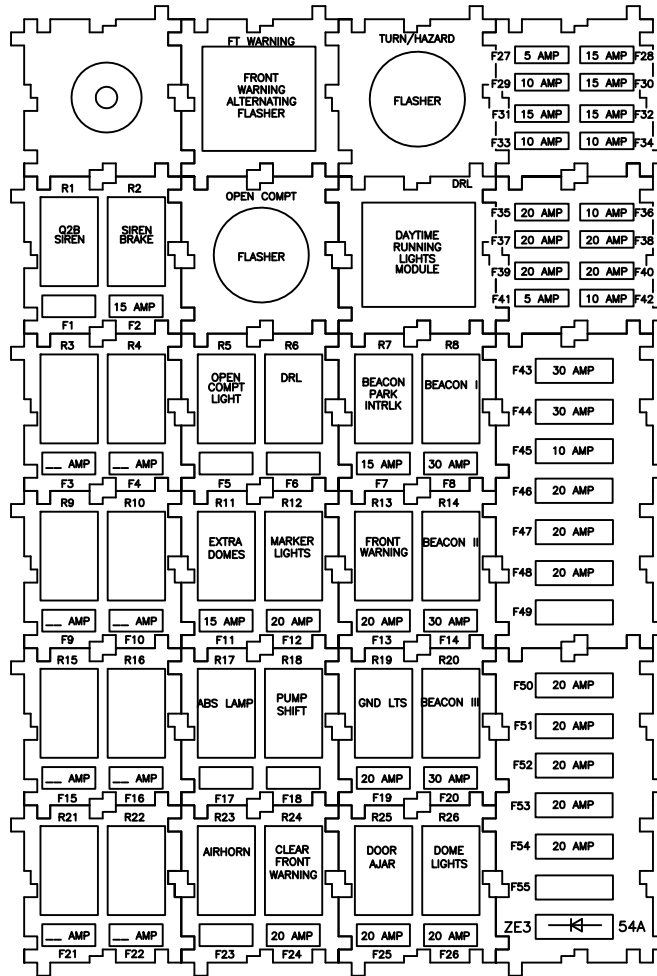

FUSE PANEL (1871 SFO/VC/W)

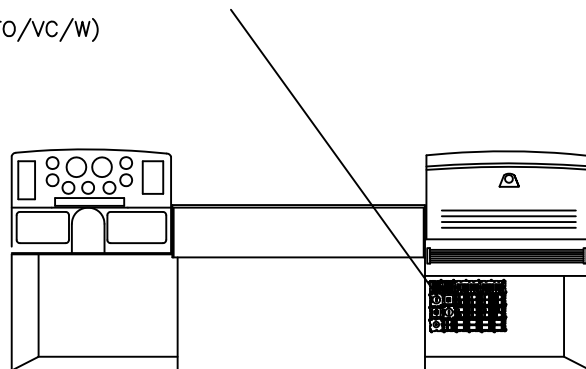

EXTERIOR LIGHTING
HEADLAMPS—NON MULTIPLEXED
(WITHOUT WIG/WAG)

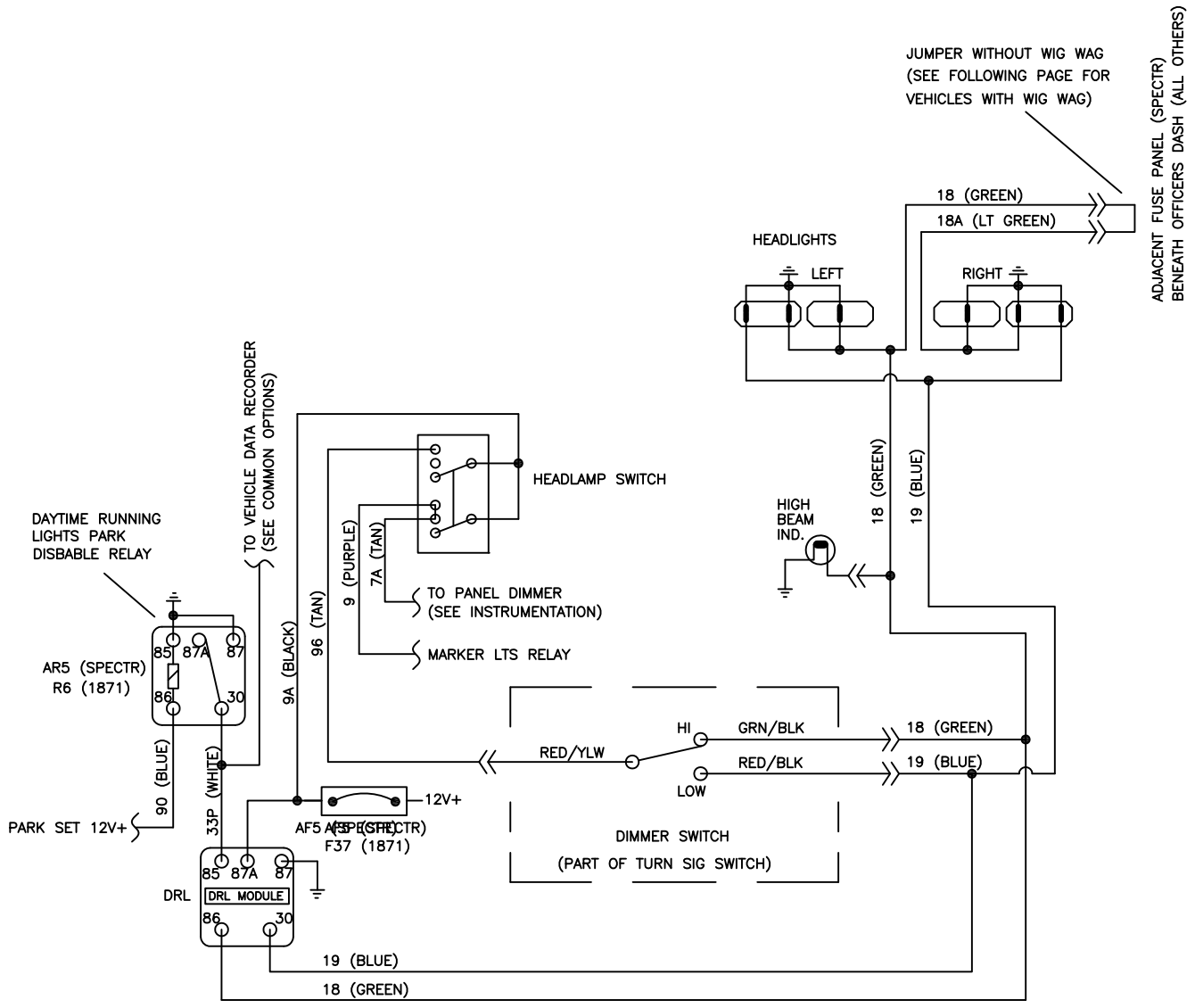

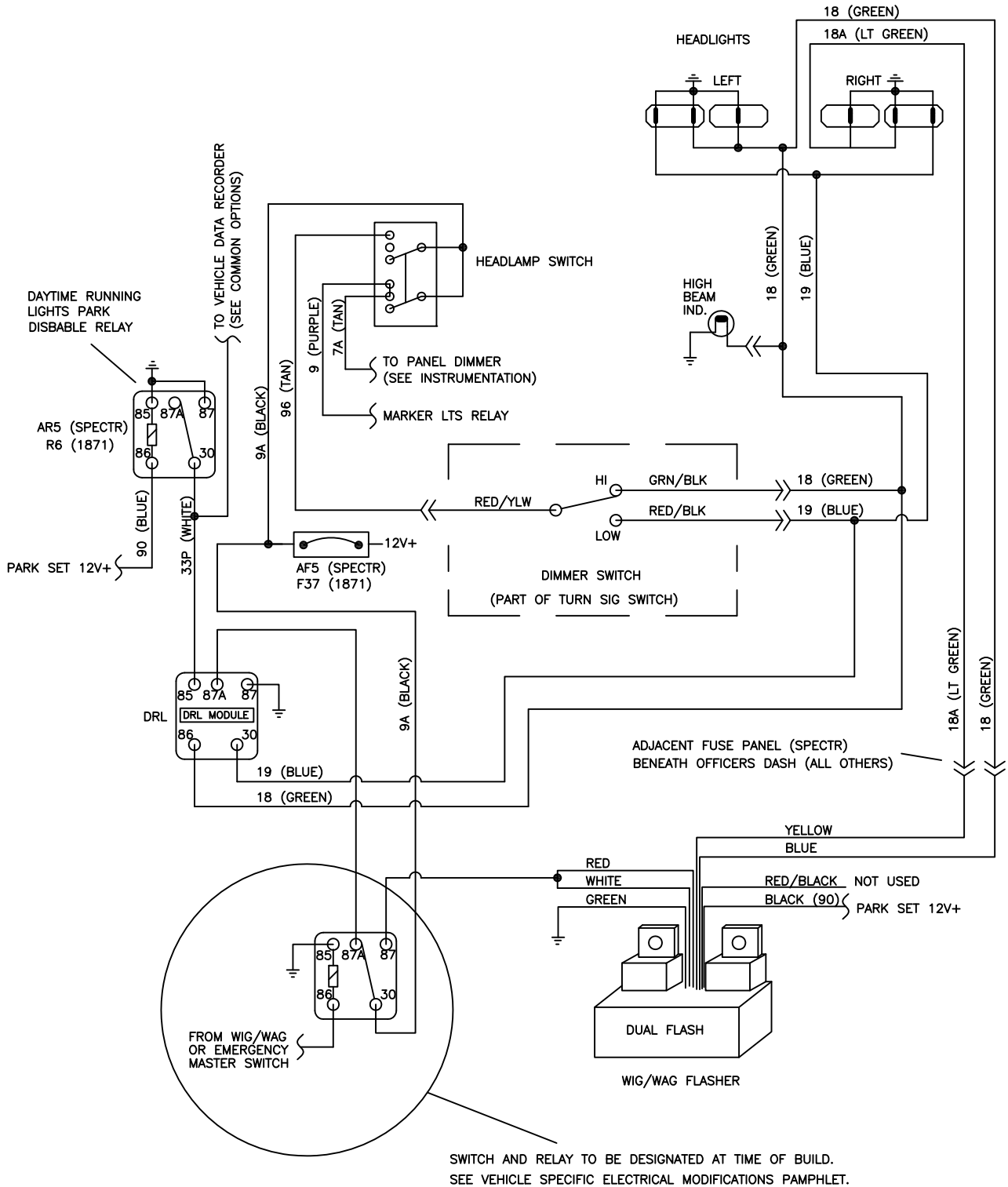

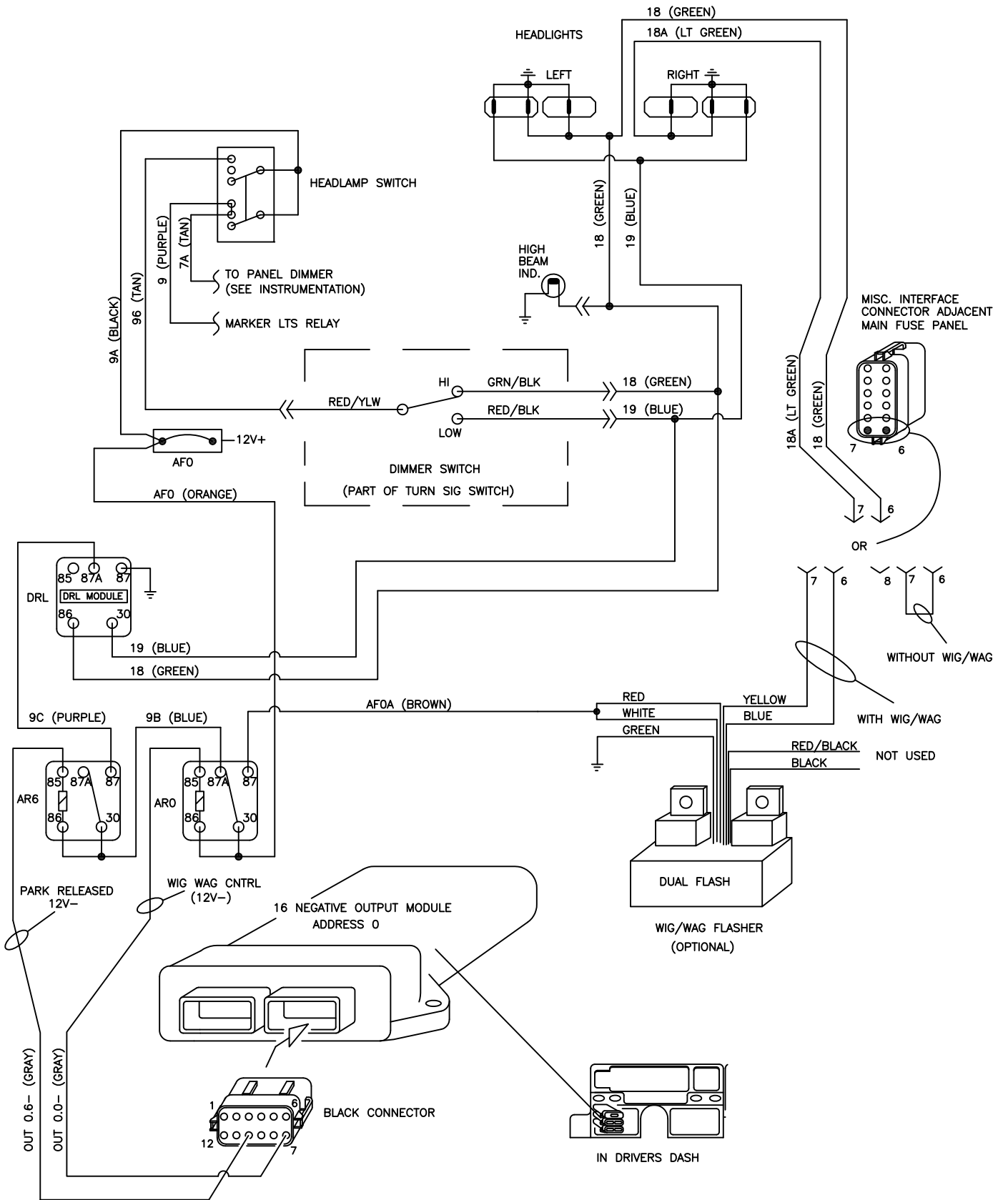

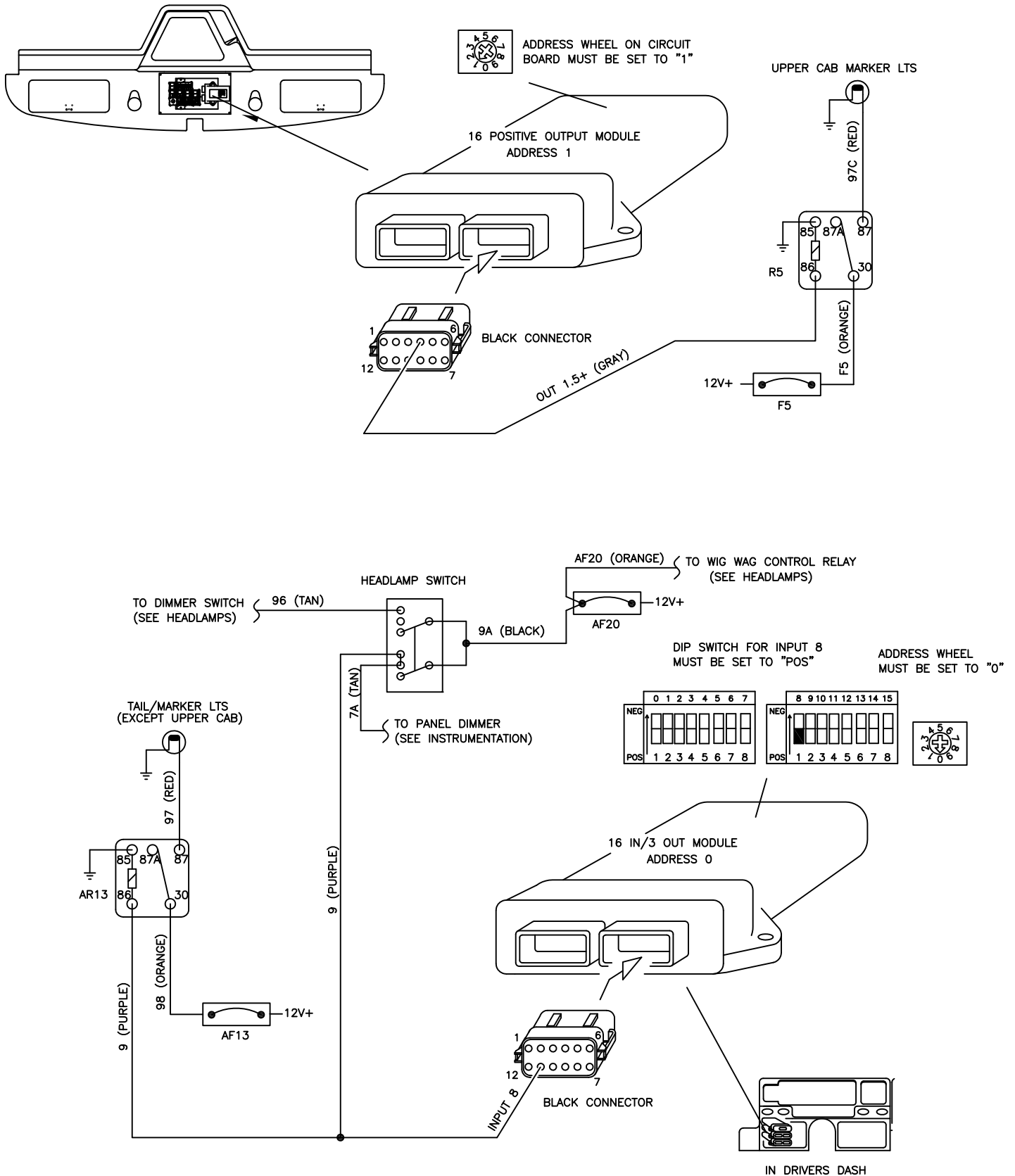

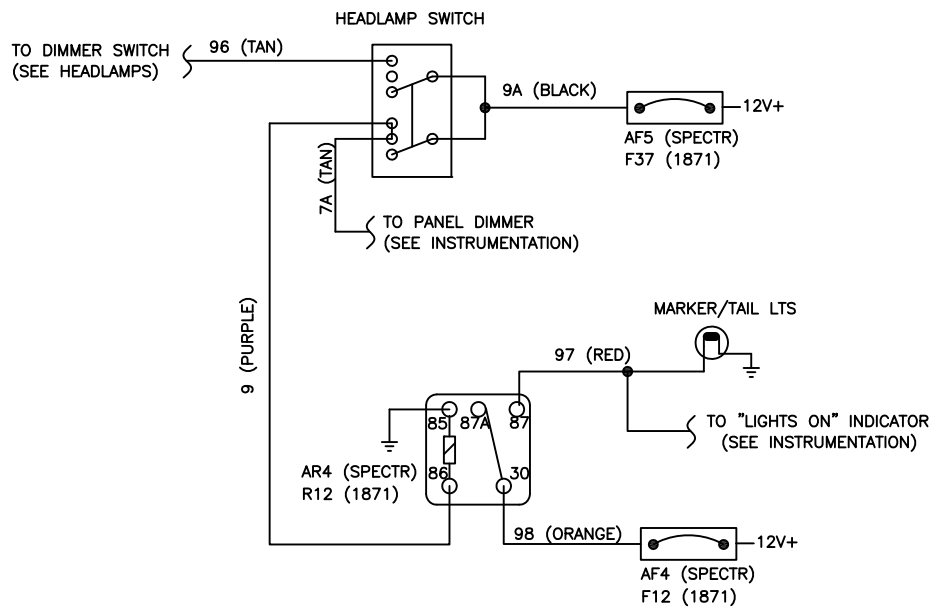

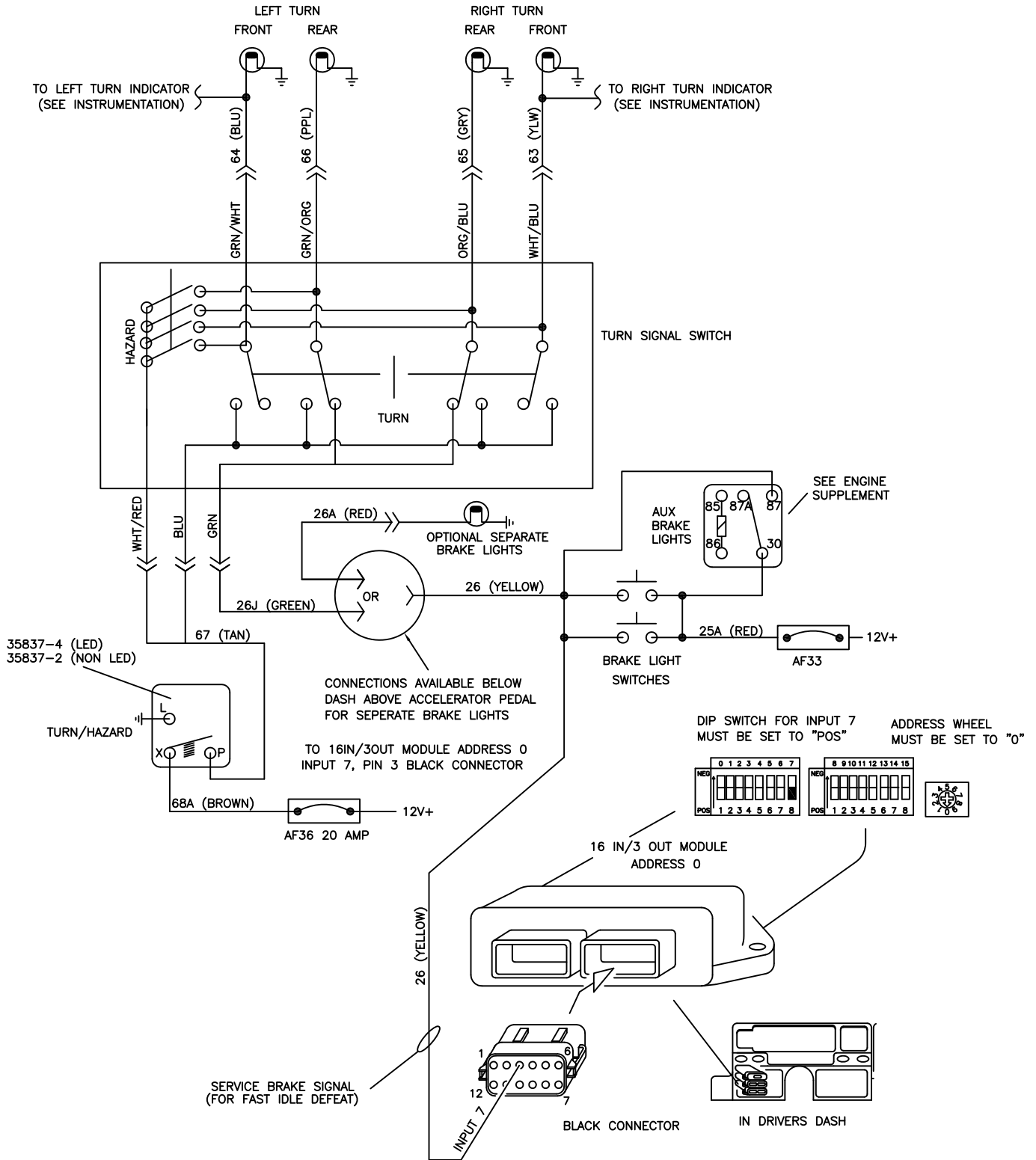

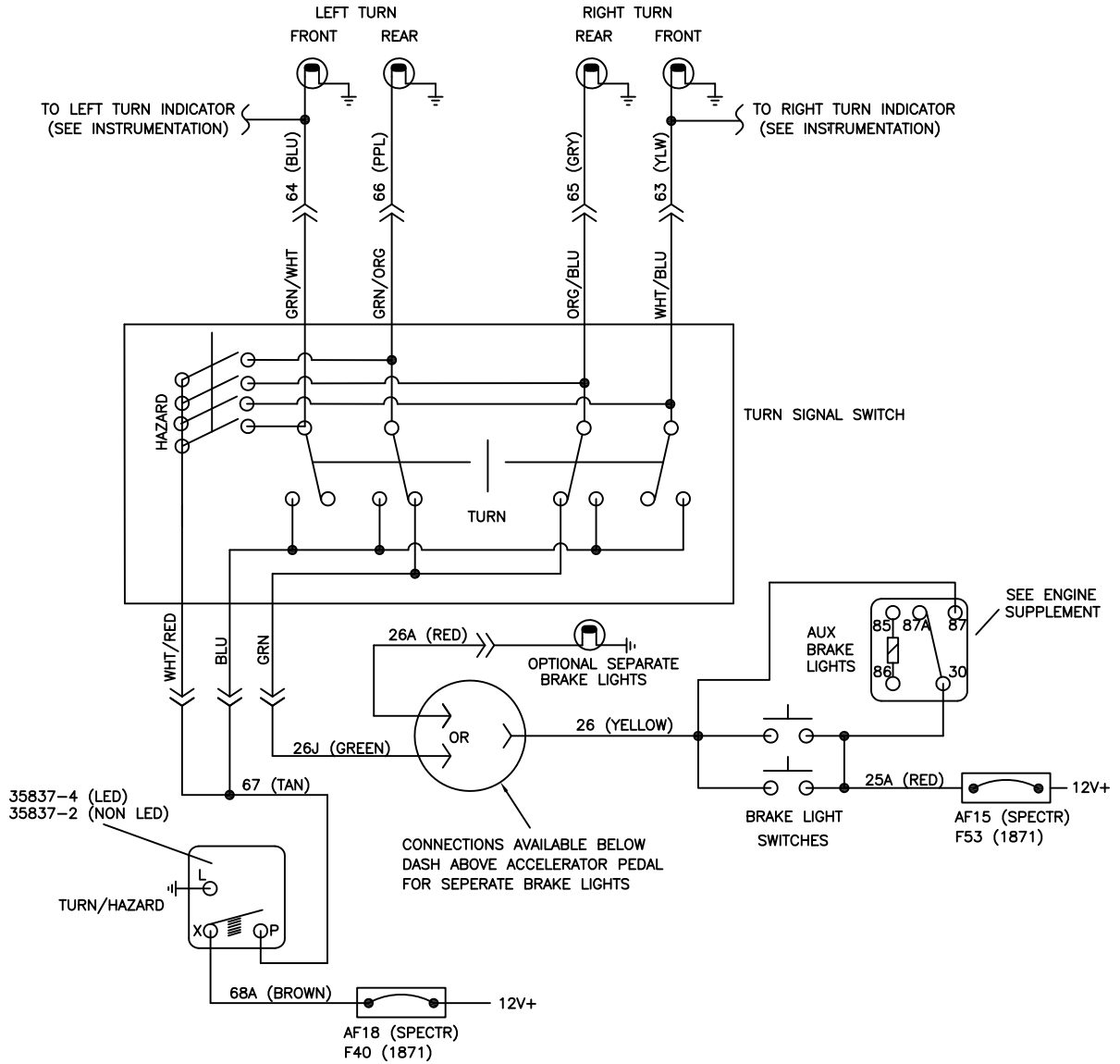

NON-MULTIPLEXED

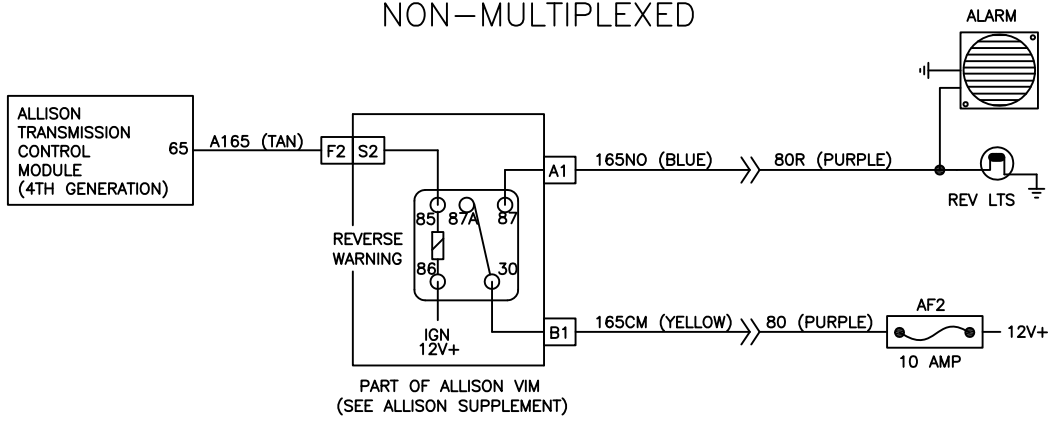

MULTIPLEXED

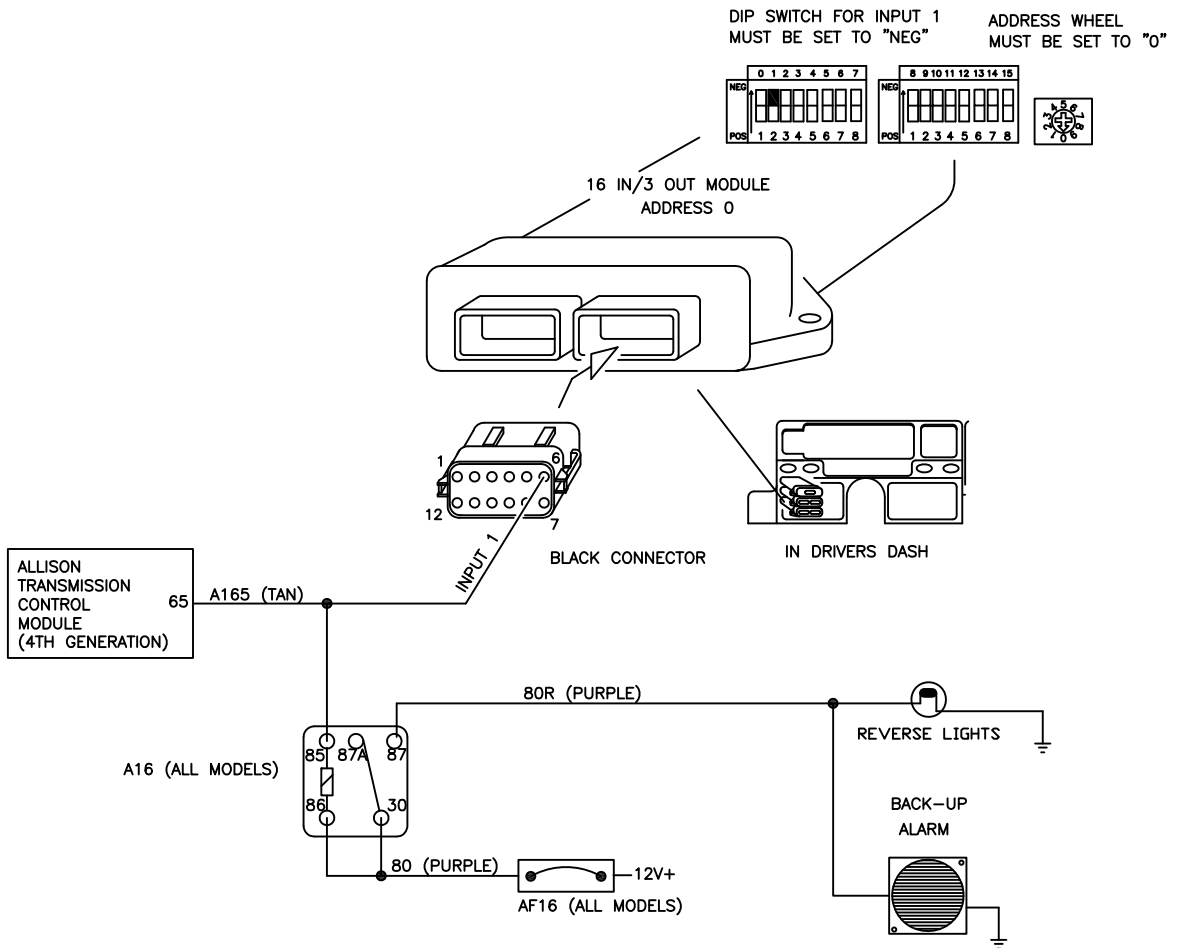

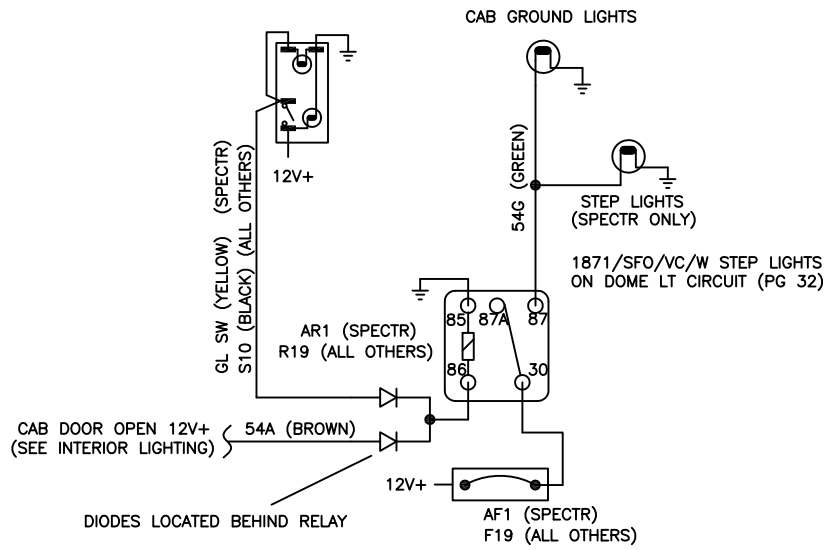

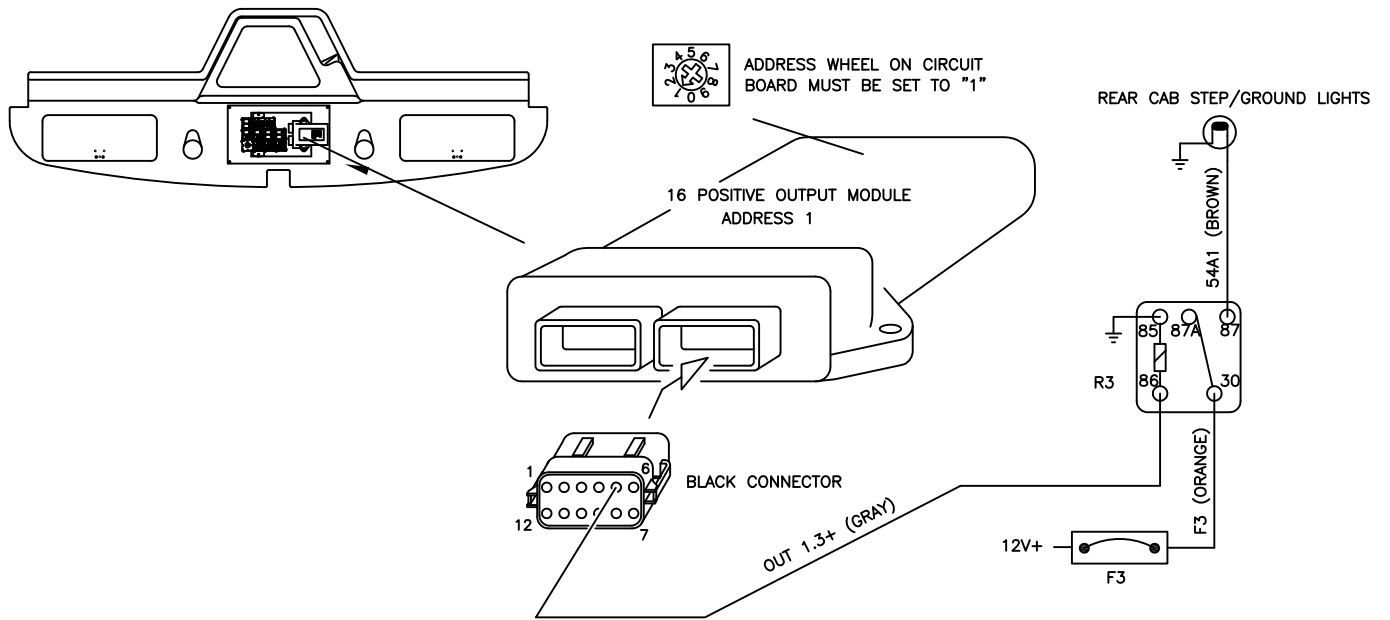
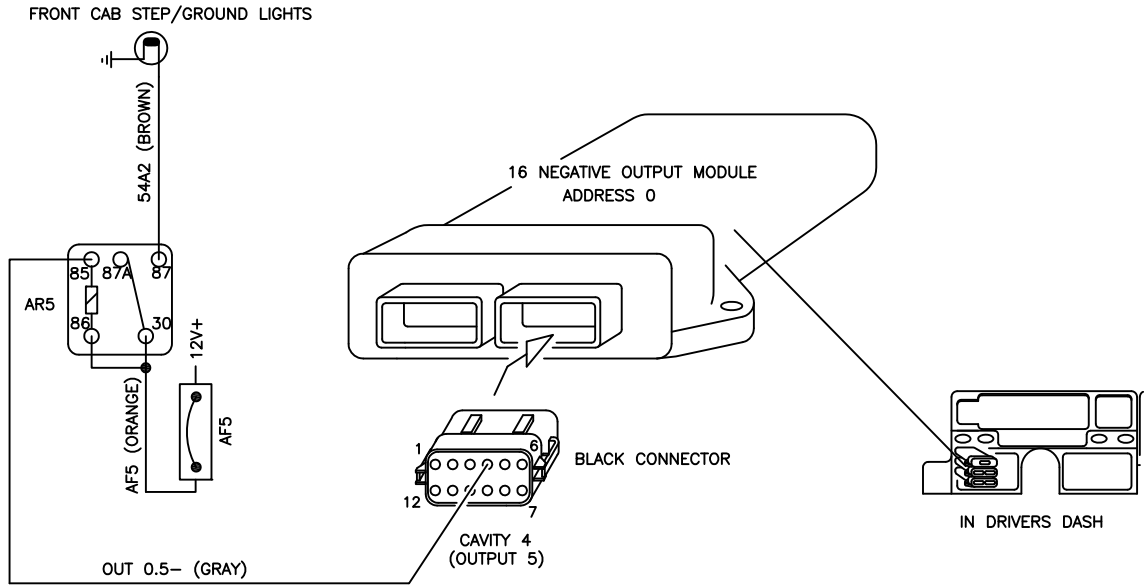

ACTIVATION TYPICALLY BASED ON DOOR SWITCH AND PARKING BRAKE STATUS.

The instrumentation is controlled by the indicator/display panel commonly referred to as the "Light Bar Message Center", or "LMC" for short. It receives it's data via discrete inputs and the J1939 powertrain data bus, then relays this information to the individual instruments on a private network and activates indicators and alarms or displays messages as necessary.

Primary connections are shown below. Individual functions are detailed on the pages that follow.

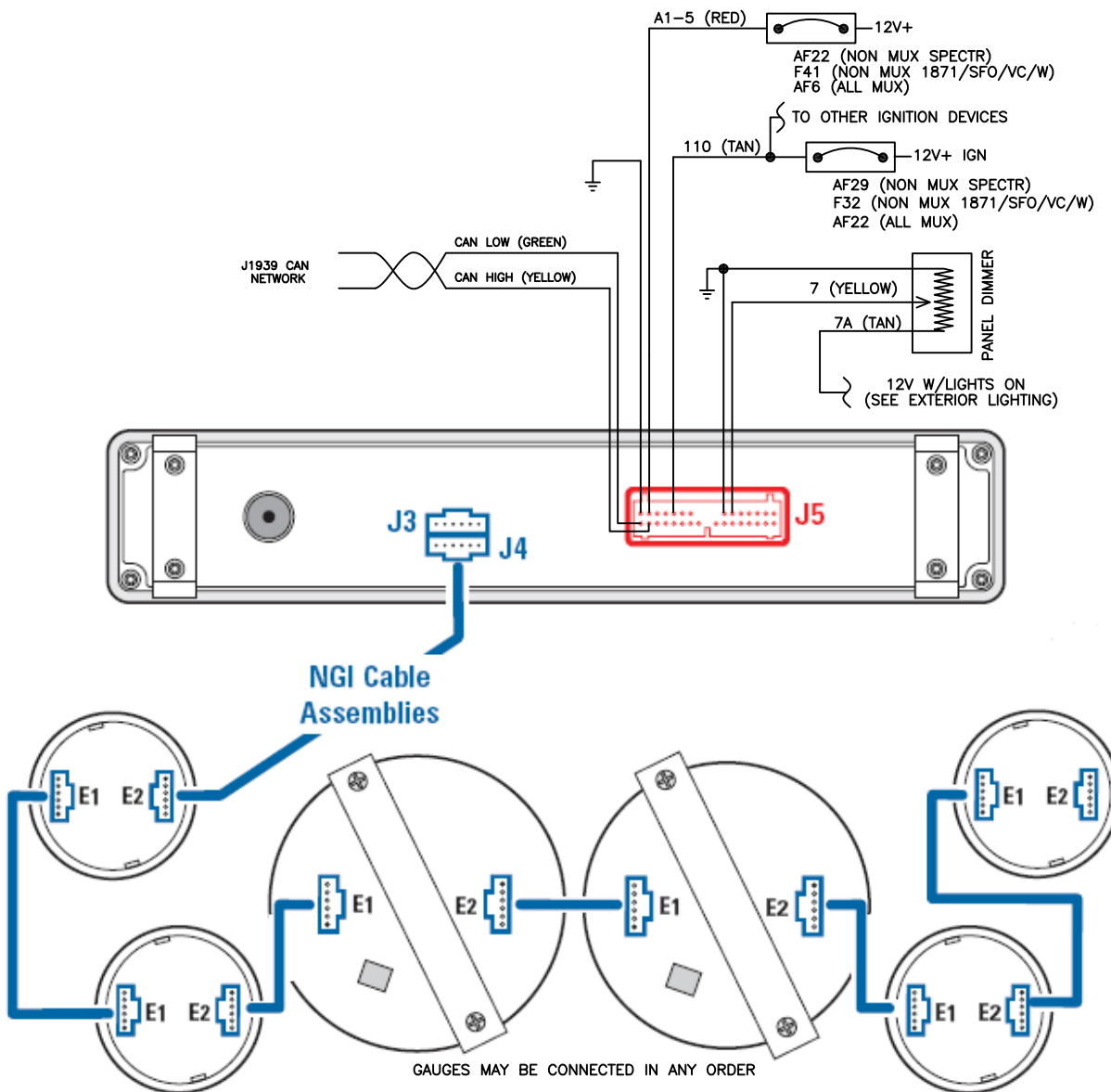
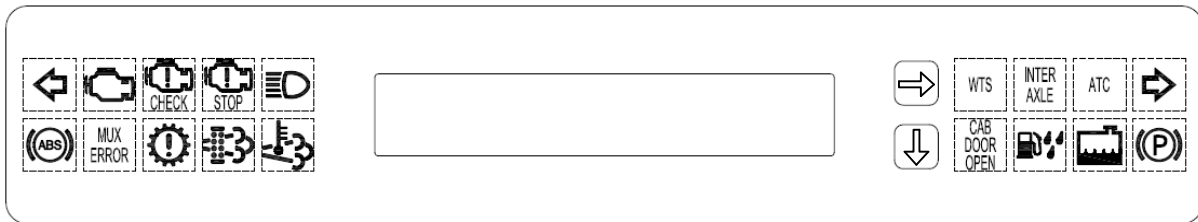

With the exception of the fuel level, all of the instruments are driven by data taken from the J1939 powertrain data bus. It is first interpreted by the "LMC", then relayed to the individual instruments on the "LIN" (Local Instrument Network). The instruments are functionally identical and can be plugged into the network at any location. Each is programmed to pull only the data it is seeking from the network. The data can also be read using the diagnostics feature in the ILB display. See "LMC Display Diagnostics" at the end of this section.

See the prior page for a schematic of the Local Instrument Network.

Fuel Level and Air Pressure inputs are defined below.

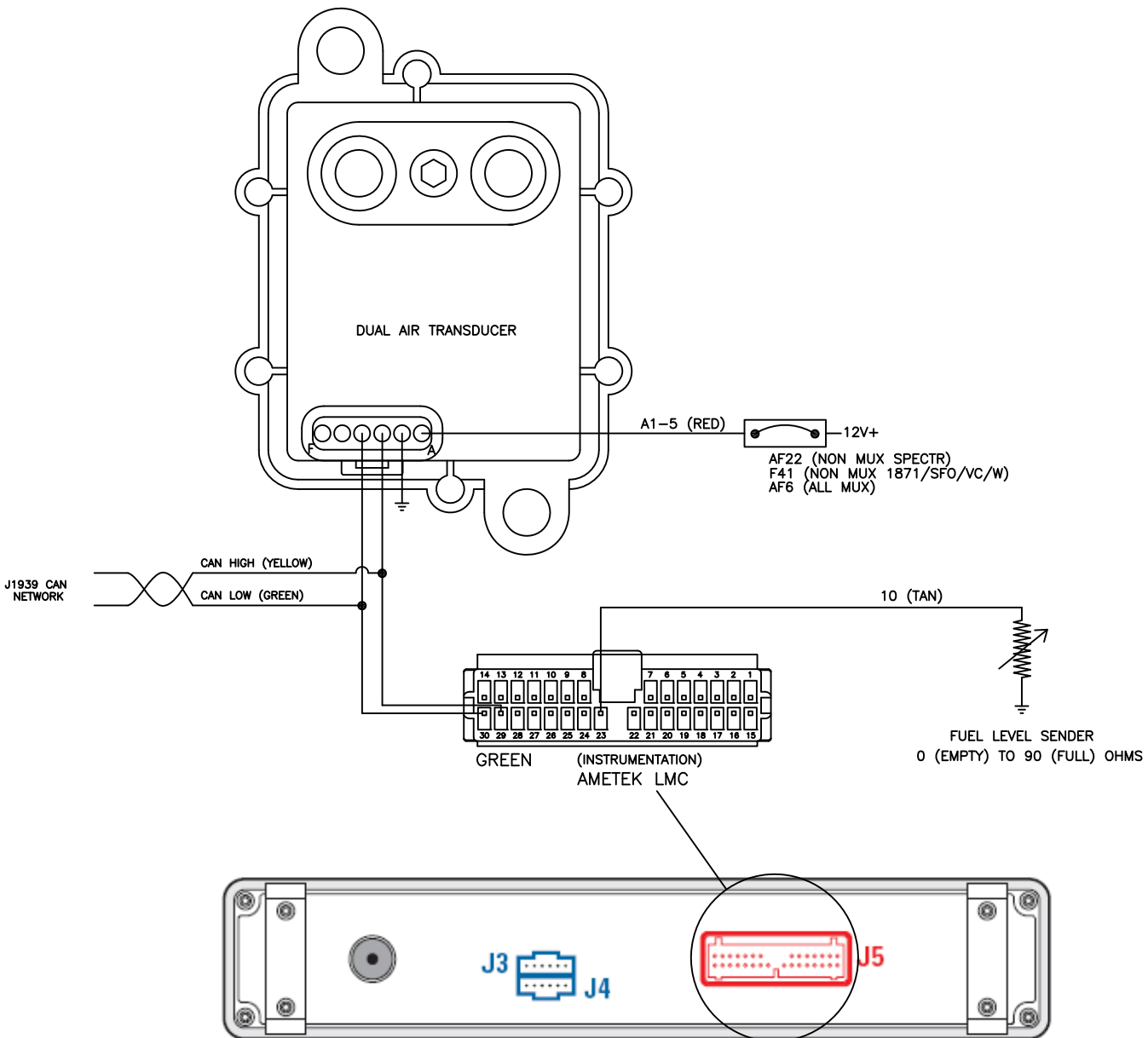

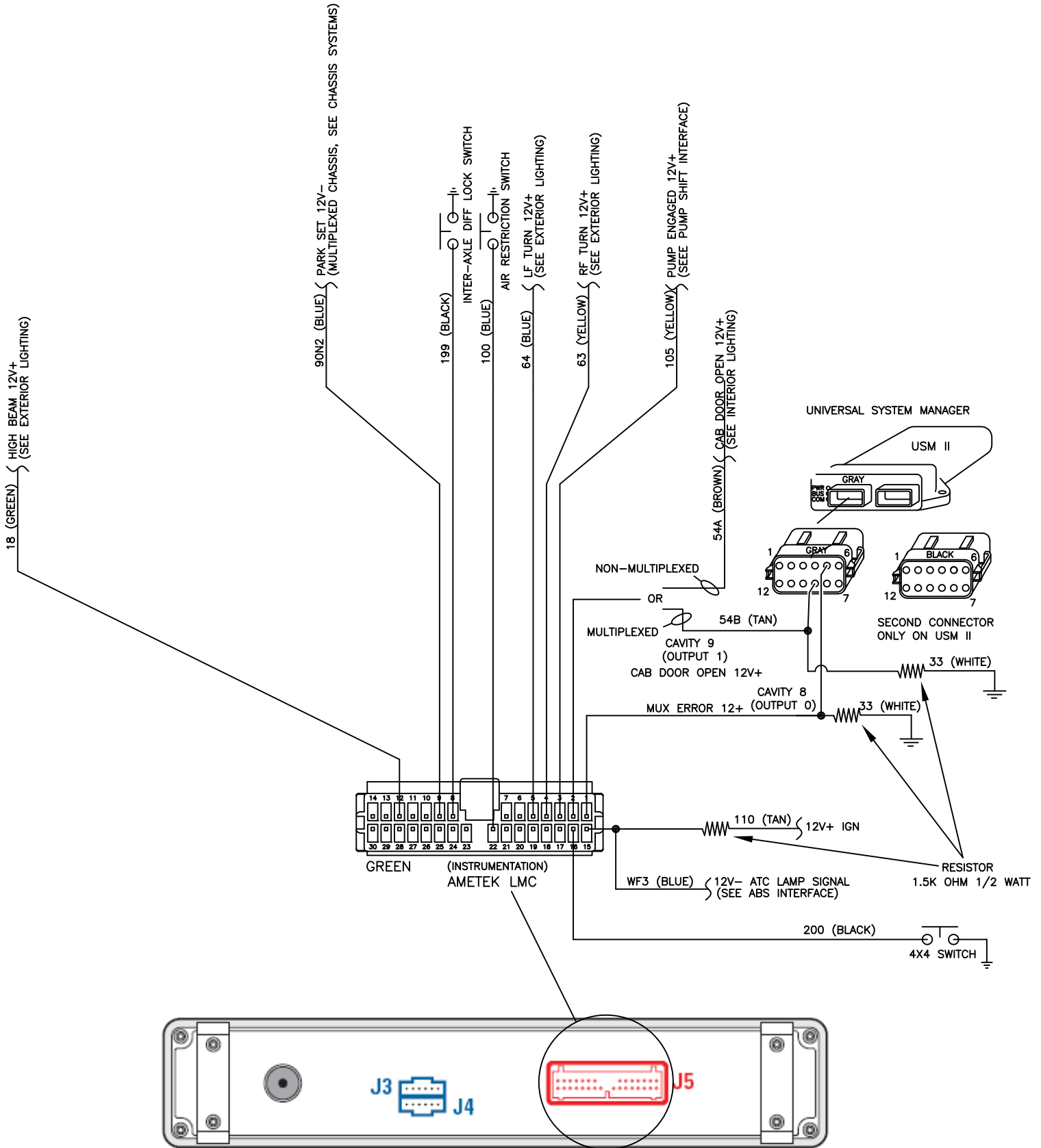

LMC Indicators and displayed messages are activated by discrete wire input (binary input), J1939 message broadcast, a data value, or any combination of these as follows.

INDICATORS

LEFT TURN [GRN]: DISCRETE INPUT
 MIL (MALFUNCTION) [AMB]: J1939 MESSAGE BROADCAST
 CHECK ENGINE [AMB]: J1939 MESSAGE BROADCAST
 STOP ENGINE [RED]: J1939 MESSAGE BROADCAST
 HIGH BEAM [BLU]: DISCRETE INPUT
 WAIT TO START [AMB]: J1939 MESSAGE BROADCAST
 INTER-AXLE [AMB]: DISCRETE INPUT
 ATC [AMB]: DISCRETE INPUT
 RIGHT TURN [GRN]: DISCRETE INPUT
 ABS [AMB]: J1939 MESSAGE BROADCAST
 MUX ERROR (MULTIPLY ERROR) [RED]: DISCRETE INPUT
 CHECK TRANSMISSION [AMB]: J1939 MESSAGE BROADCAST
 DPF (PARTICULATE FILTER) [AMB]: J1939 MESSAGE BROADCAST
 HEST (HIGH EXHAUST TEMP) [AMB]: J1939 MESSAGE BROADCAST
 CAB DOOR OPEN [RED]: DISCRETE INPUT
 WATER IN FUEL [RED]: J1939 MESSAGE BROADCAST
 LOW COOLANT [AMB]: J1939 MESSAGE BROADCAST
 PARK BRAKE [RED]: DISCRETE INPUT

GAUGE INDICATORS

LOW AIR [RED]: J1939 MESSAGE BROADCAST
 DIESEL EXHAUST FLUID [AMB]: J1939 MESSAGE BROADCAST
 SYSTEM VOLTAGE [RED]: J1939 MESSAGE BROADCAST
 TRANSMISSION TEMPERATURE [RED]: J1939 BROADCAST MESSAGE
 ENGINE OIL [RED]: J1939 MESSAGE BROADCAST
 WATER TEMPERATURE [RED]: J1939 MESSAGE BROADCAST

POP-UP MESSAGES

LOW OIL PRESSURE: J1939 MESSAGE BROADCAST
 HIGH COOLANT TEMP: J1939 MESSAGE BROADCAST
 TRANS OVER TEMP: J1939 MESSAGE BROADCAST
 LOW FRONT AIR: LESS THAN 65 PSI OR GREATER THAN 70 PSI
 LOW REAR AIR: LESS THAN 65 PSI OR GREATER THAN 70 PSI
 LOW COOLANT LEVEL: J1939 MESSAGE BROADCAST
 LOW VOLTAGE: LESS THAN 12 VOLTS
 HIGH VOLTAGE: GREATER THAN 15.4 VOLTS
 STOP ENGINE: J1939 MESSAGE BROADCAST
 LOW FUEL: LESS THAN 12.5%
 ABS FAULT: J1939 MESSAGE BROADCAST
 WATER IN FUEL: J1939 MESSAGE BROADCAST
 CHECK ENGINE: J1939 MESSAGE BROADCAST
 CHECK TRANSMISSION: J1939 MESSAGE BROADCAST
 NO TRANS COMMUNICATION: 5 CONTINUOUS SECONDS WITH LOSS OF DATA
 PARK BRAKE ON VEHICLE MOVING: PARK BRAKE ON WITH SPEED ABOVE 2MPH
 NO ENGINE COMMUNICATION: 5 CONTINUOUS SECONDS WITH LOSS OF DATA
 SERVICE DUE: TRUCK HAS EXCEEDED SET MILAGE SINCE ALARM WAS SET
 DPF REGEN REQUIRED: J1939 MESSAGE BROADCAST (DPF AT LOWEST LEVEL)
 HIGH EXHAUST TEMP: J1939 MESSAGE BROADCAST
 DEF LEVEL CRITICAL: DIESEL EXHAUST FLUID AT LOWEST LEVEL
 INTAKE AIR RESTRICTION: DISCRETE INPUT
 4X4 OVERSPEED: 4X4 ACTIVE AND SPEED IS GREATER THAN 25 MPH
 TURN SIGNAL ON: EITHER LEFT OR RIGHT TURN SIGNAL ON FOR MORE THAN ONE MILE
 ENGINE NOT RUNNING: ENGINE ROTATION LESS THAN 10 RPM
 PUMP ENGAGED: DISCRETE INPUT

START UP LAMP TEST

Upon ignition all pointers will zero and all indicators will illuminate for 2 seconds and then turn off. All segments in the LCD display will activate for this same period.

After approximately 1 more second active indicators will return, any wanting messages will appear on the screen (press the [→] button to clear), then the odometer reading will be appear in the LCD display, and instrument pointers will move to their commanded positions.

Note: The WTS (Wait To Start) indicator does not self test, but instead will be properly displaying status.

ODOMETER/TRIPMETER

The odometer value is maintained in the LMC and displayed in the speedometer LCD. It has a maximum possible value of 999,999.9 (will not roll over) and is not field serviceable.

There are two tripmeters (labeled TRIP1 & TRIP2) displayed in the LMC LCD. Depress the [→] button to cycled through the available menus to the tripmeter menu if you are not already there. Depres the [↓] button until you reach the desired tripmeter. Depressing the [→] button for 3 seconds while either tripmeter is displayed will reset that tripmeter to "0".

DATA MONITOR SCREENS

The information screens by default display the following Information:

<u>SCREEN 1</u>	<u>SCREEN 2</u>	<u>SCREEN 3</u>	<u>SCREEN 4</u>
ODOMETER	TRIP1	INSTANT MPG	SPEED
ENGINE TEMP	TRIP2	AVERAGE MPG	ODOMETER

The information displayed in each screen can be configured with the exception of the odometer in screen 1. This is achieved by depressing the [↓] button until the setup menu is reached. Depressing the [→] button once will allow the user to select unit type (English or Metric) by pressing the [↓] button to toggle. Each following press of the [→] button will toggle through the four information screens. Toggle to the desired screen then press the [↓] button to select the screen. Press the [↓] button to select the top line or press the [→] then [↓] buttons for the bottom line. To cycle through the available display information options press the [↓] button. When the desired information is displayed press the [→] button to confirm the change.

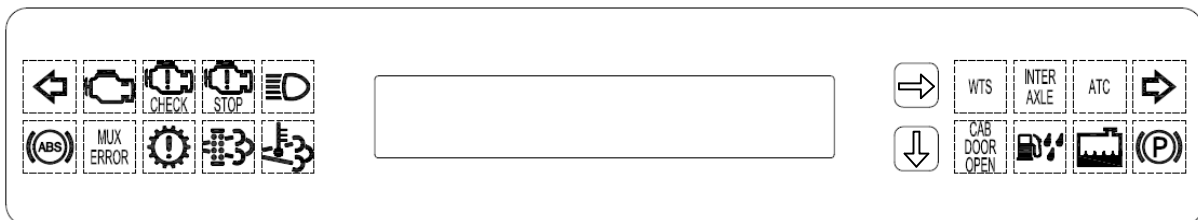

USER DIAGNOSTICS

To see the diagnostics by the LMC, Depress the [↓] button until the diagnostic menu is displayed.

Press the [→] button once to access the warning messages. Press the [↓] button to cycle through all active diagnostic messages.

Press the [→] button again to get the the fault code menu. Pressing the [↓] button will cycle through the active fault codes.

SELF TESTS

To access the self test modes, depress the [↓] button until the Self Test Menu is displayed.

Press the [→] button once to get to the auto self test. Pressing the [↓] button will start the auto self test. While the auto self test active, all gauges will toggle from off, to half level, to full continuously. The indicator lights and telltales should be active when the gauges are at the full level. Press the [→] button to stop the self test.

Press the [→] button again to access the manual test menu. Press the [↓] button once to get to the gauge selection screen. Pressing the [→] button will cycle through the gauges, with the telltale option at the end. Press the [↓] button when a gauge is displayed to select it. Pressing the [↓] button will cycle from off, to half level, to full level. If there is a light in the Gauge it will come on when the gauge is at the full level. Pressing the [↓] button while over the telltale option will cycle through all of the telltale lights in the LMC.

Press the [→] button a third time to reach the software information. This screen will display the Software version and the Configuration number.

SERVICE ALARM

To access the self test modes, Press the [↓] button until the service alarm menu is displayed.

To activate the service alarm press the [→] button once, then hold the [→] button for 3 seconds. The LMC will now allow the user to input service miles. Press the [↓] button to cycle the set mileage. The alarm ranges from 3,000 to 20,000 miles in increments of 1,000. Between 20,000 and 3,000 miles it allows for an off option.

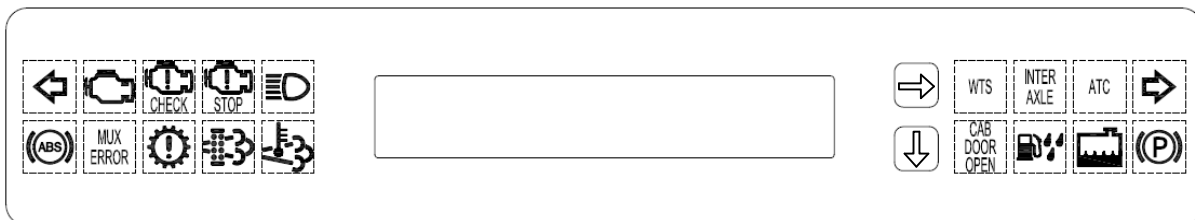

SCHEMATICS

SWITCH PANEL
(NON MULTIPLEXED 1871 SFO/VC/W)

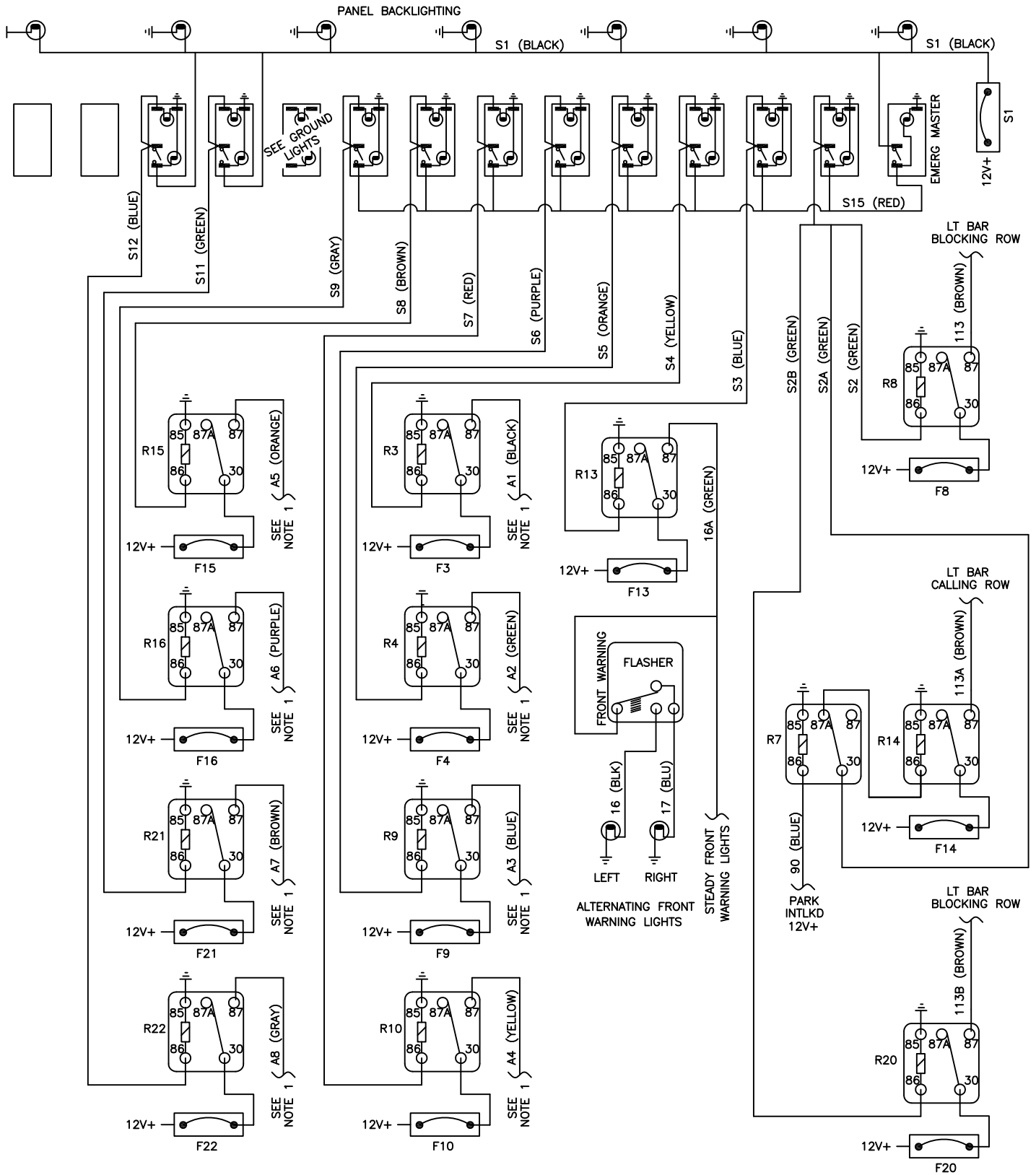

NOTE 1: SEE ELECTRICAL MODIFICATIONS PAMPHLET FOR INFORMATION ON USE OF AUXILIARY SWITCH RELAY OUTPUTS.
ALL UNUSED AUXILIARY SWITCH RELAY OUTPUTS TERMINATE ABOVE THE FUSE/RELAY PANEL AS BLUNT CUT WIRES.

ALL BEACON CIRCUITS RUN TO OVERHEAD FOR LIGHTBAR INTERFACE

SCHEMATICS

SWITCH PANEL
(NON MULTIPLEXED SPECTR)

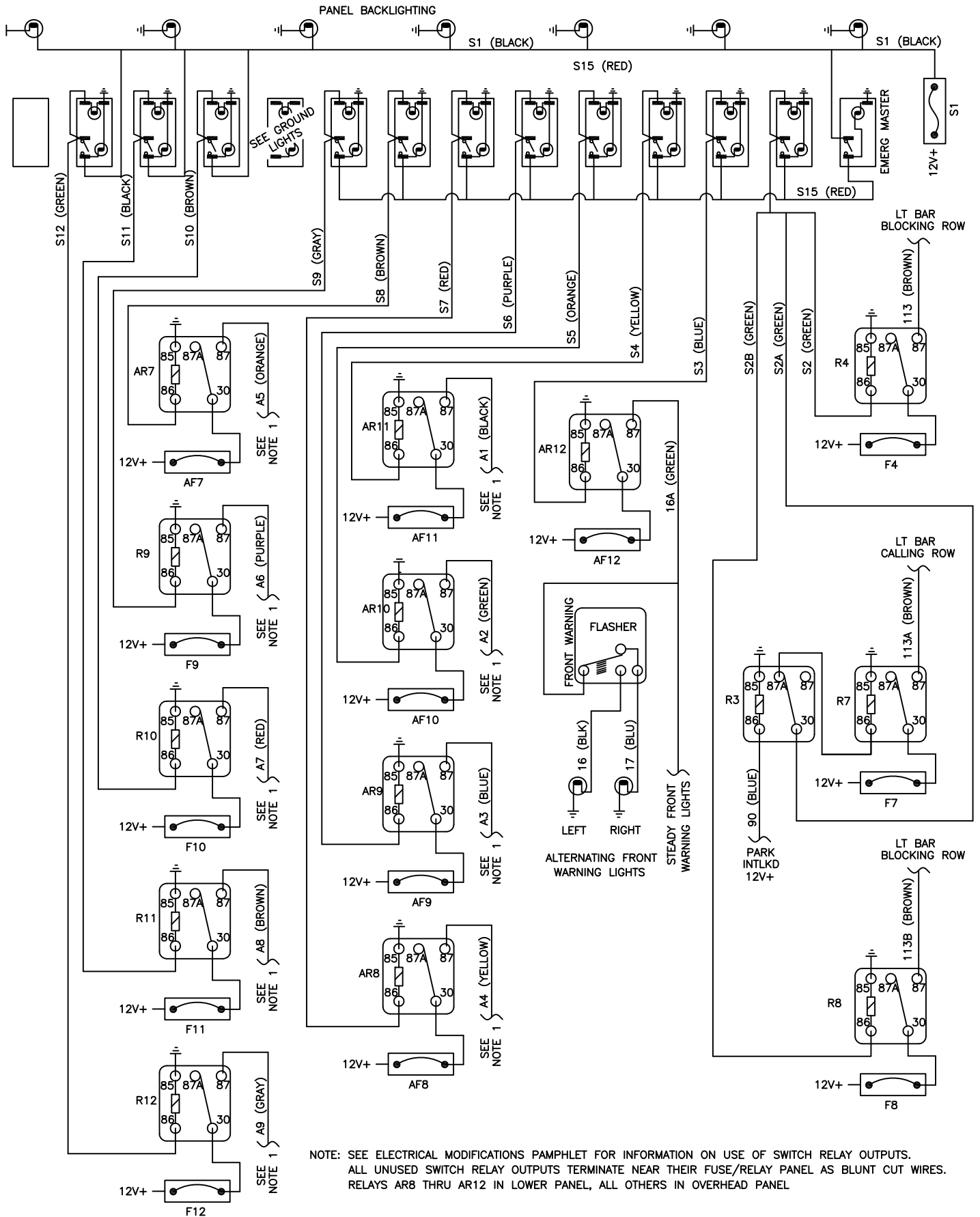

NOTE: SEE ELECTRICAL MODIFICATIONS PAMPHLET FOR INFORMATION ON USE OF SWITCH RELAY OUTPUTS.
ALL UNUSED SWITCH RELAY OUTPUTS TERMINATE NEAR THEIR FUSE/RELAY PANEL AS BLUNT CUT WIRES.
RELAYS AR8 THRU AR12 IN LOWER PANEL, ALL OTHERS IN OVERHEAD PANEL

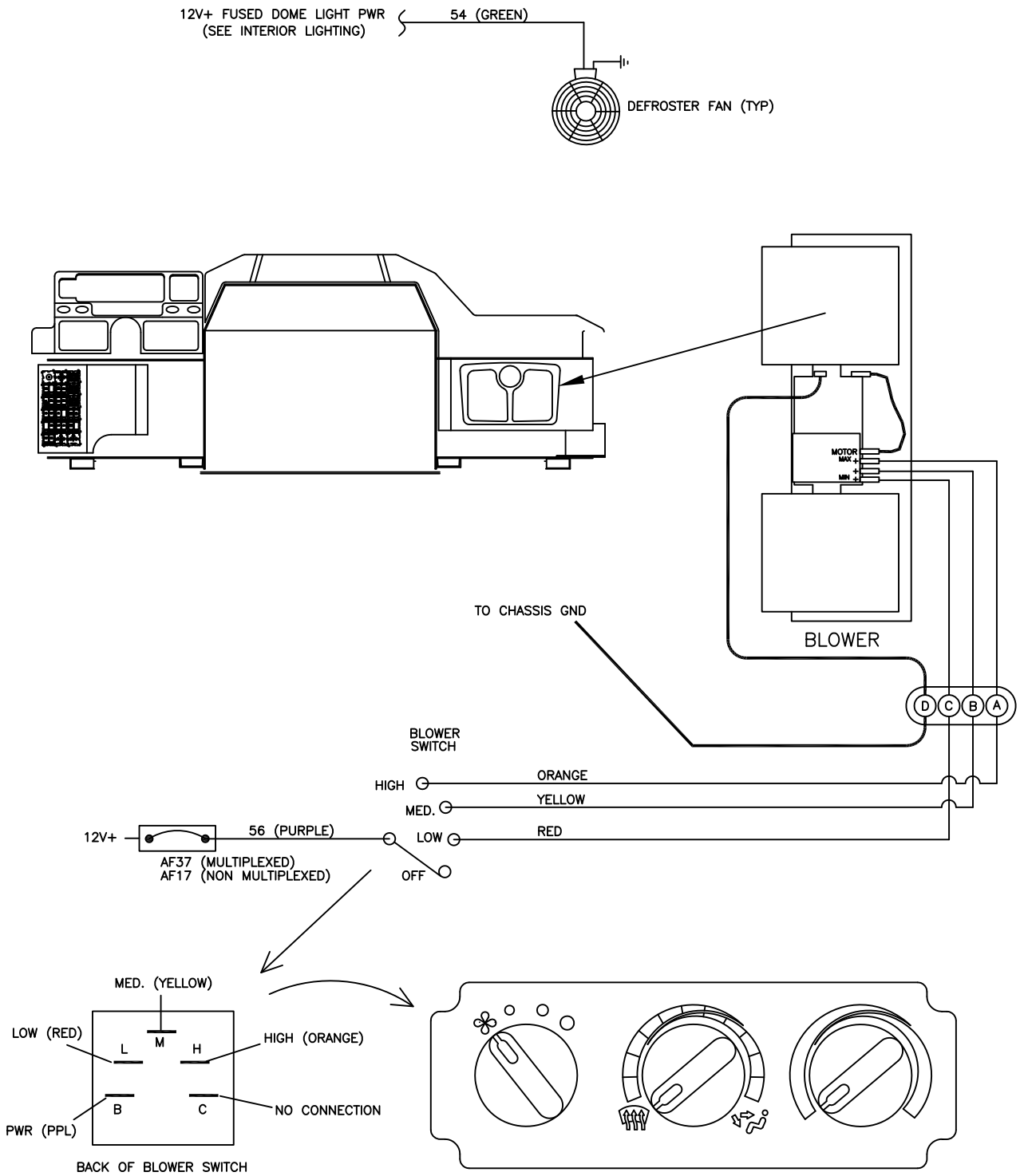

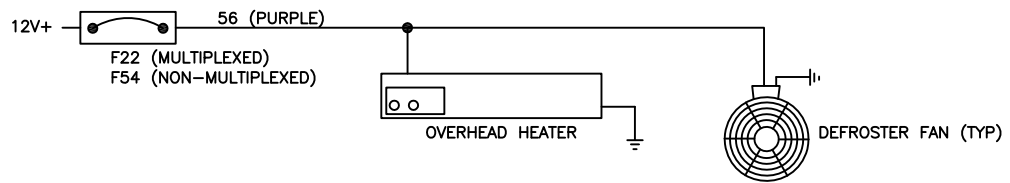

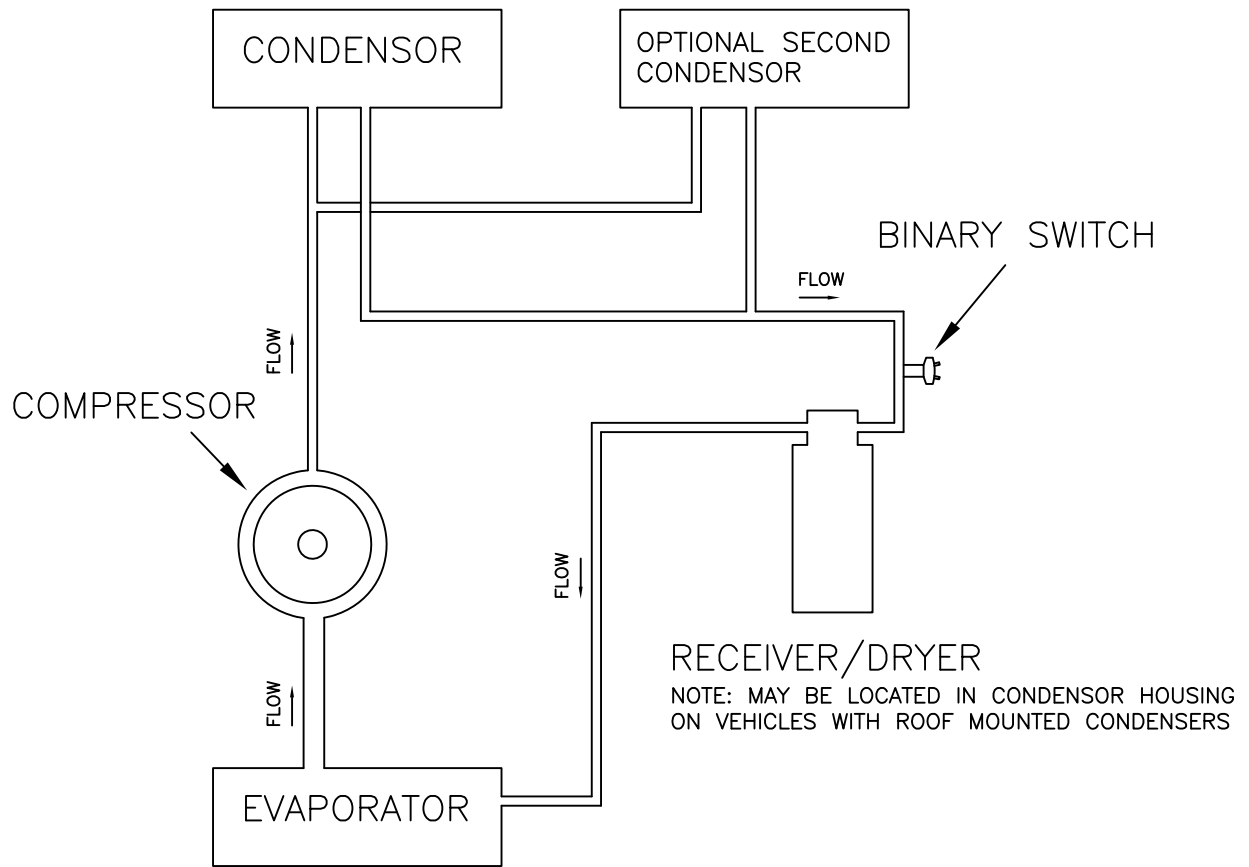

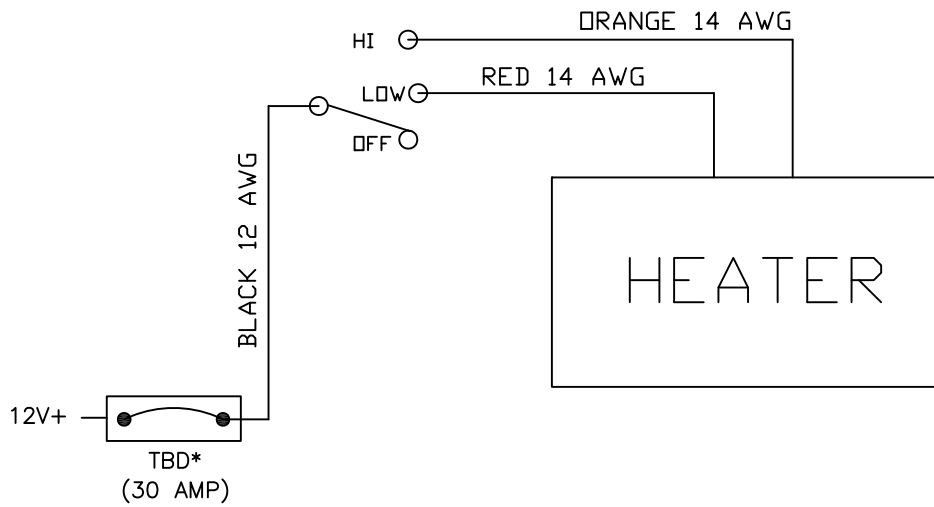

*FUSE LOCATION & IDENTIFICATION TO BE DETERMINED AT TIME OF BUILD.
SEE VEHICLE SPECIFIC ELECTRICAL MODIFICATIONS PAMPHLET.

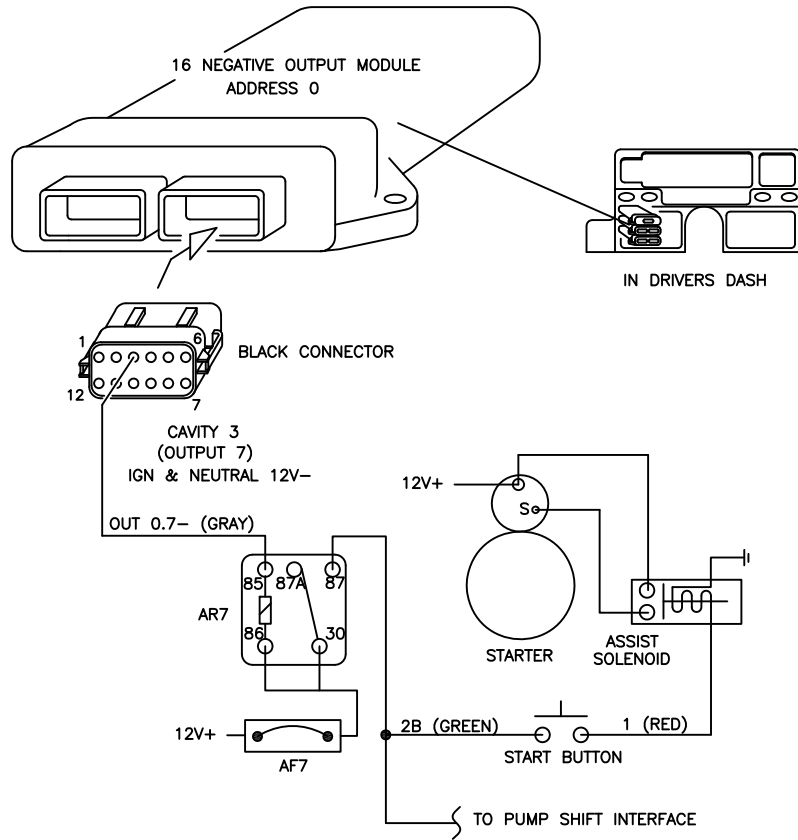

MULTIPLEXED

NON MULTIPLEXED

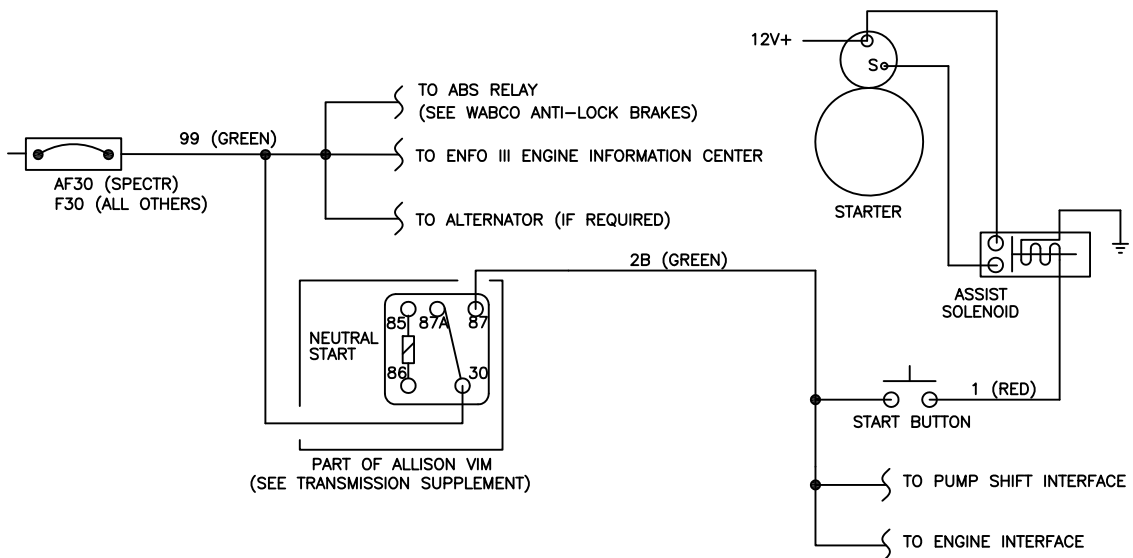

NAVISTAR MAXX FORCE 10

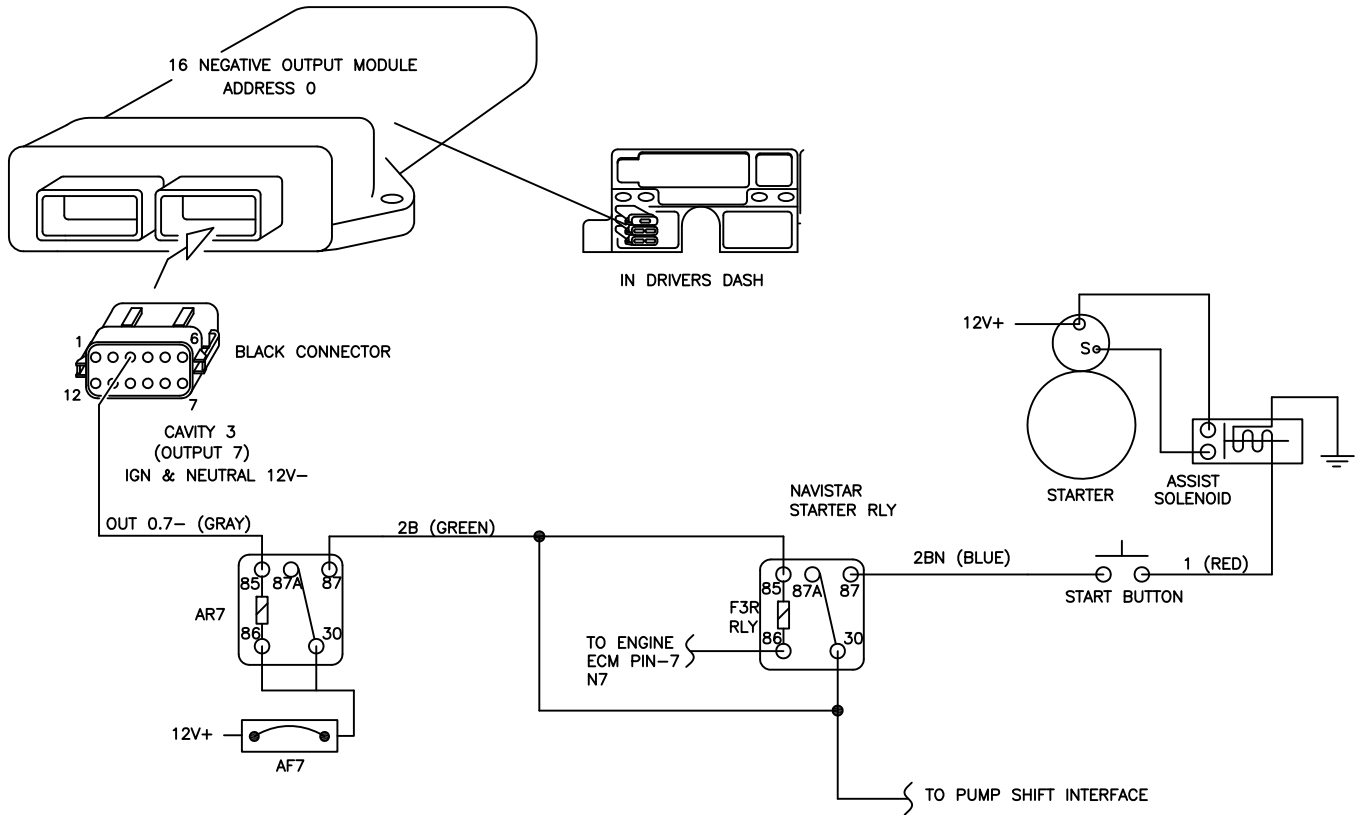

MULTIPLEXED

NON MULTIPLEXED

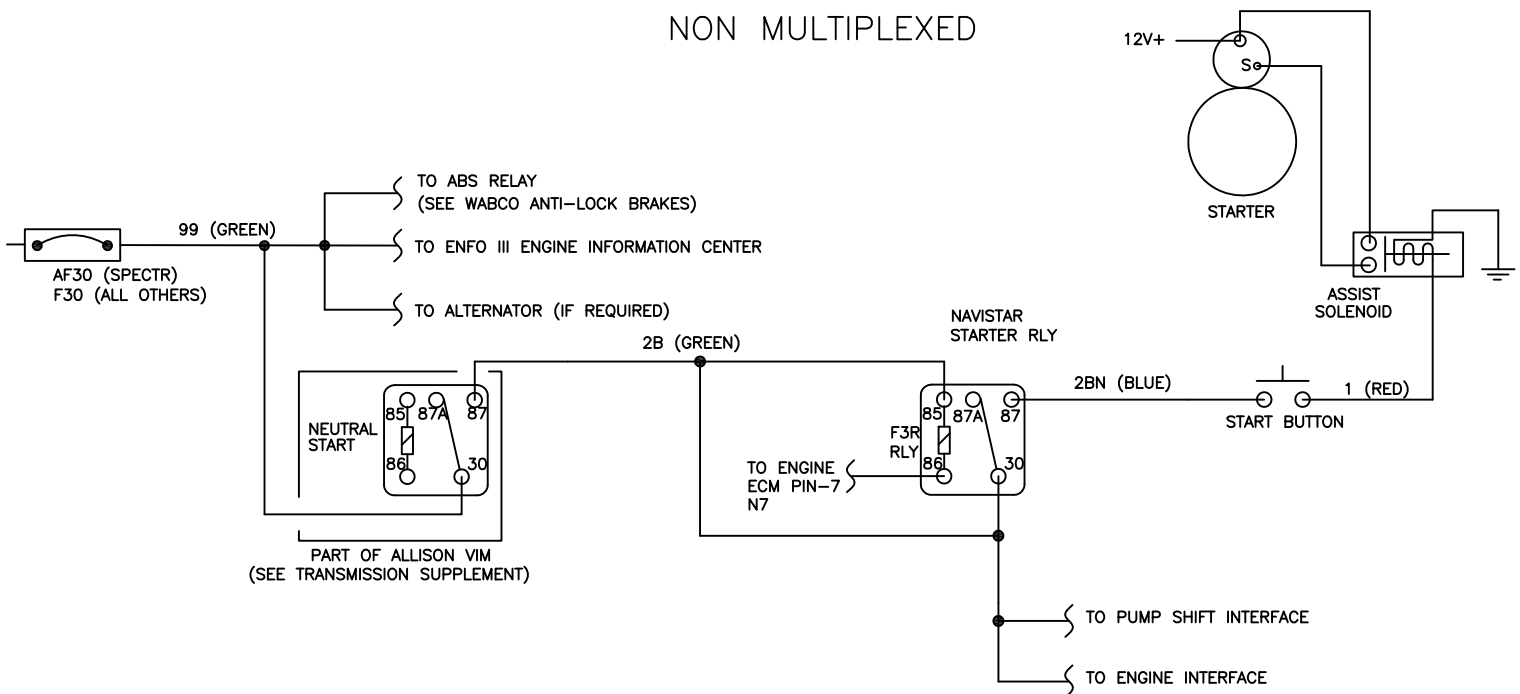

LEECE NEVILLE
(4949PA 270AMP - SELF EXCITING)
(4962PA 320AMP - SELF EXCITING)

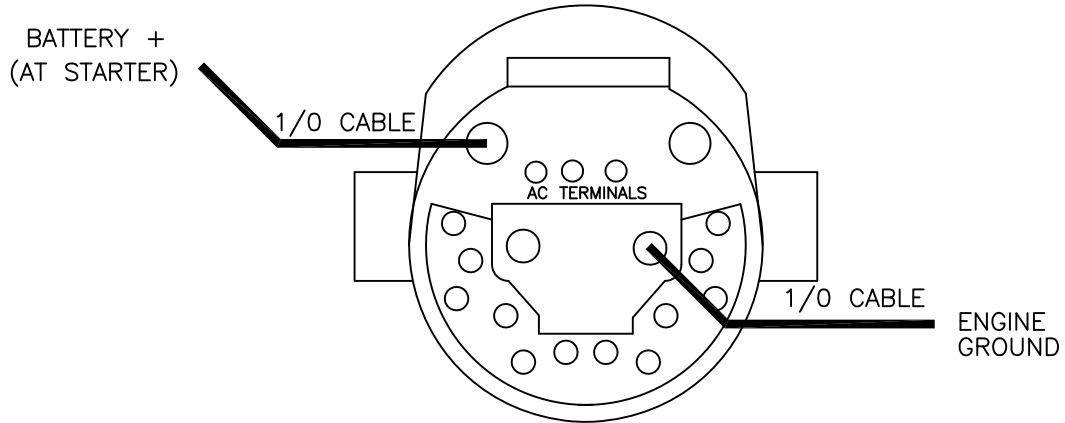

PENNTEX
(PX-6Q-275 : 275 AMP EXTERNALLY REGULATED)
(PX-6Q-350 : 350 AMP EXTERNALLY REGULATED)

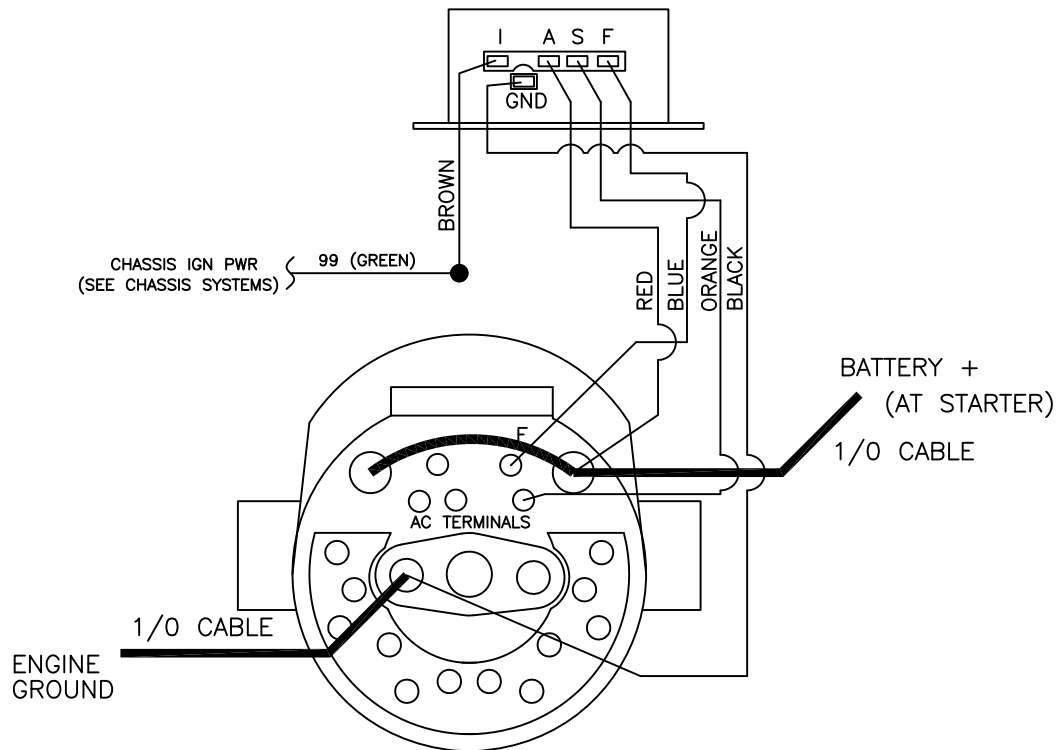

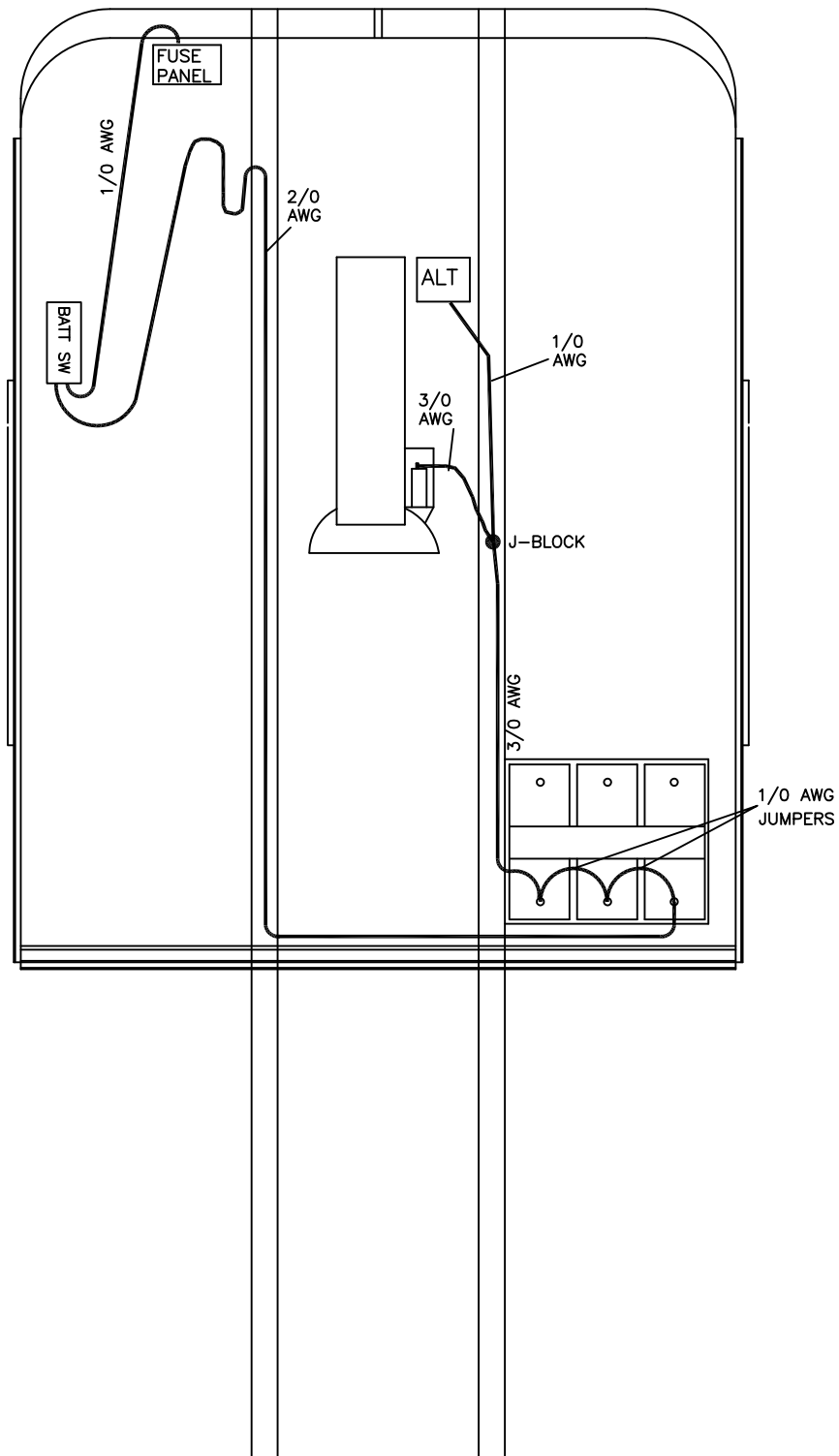

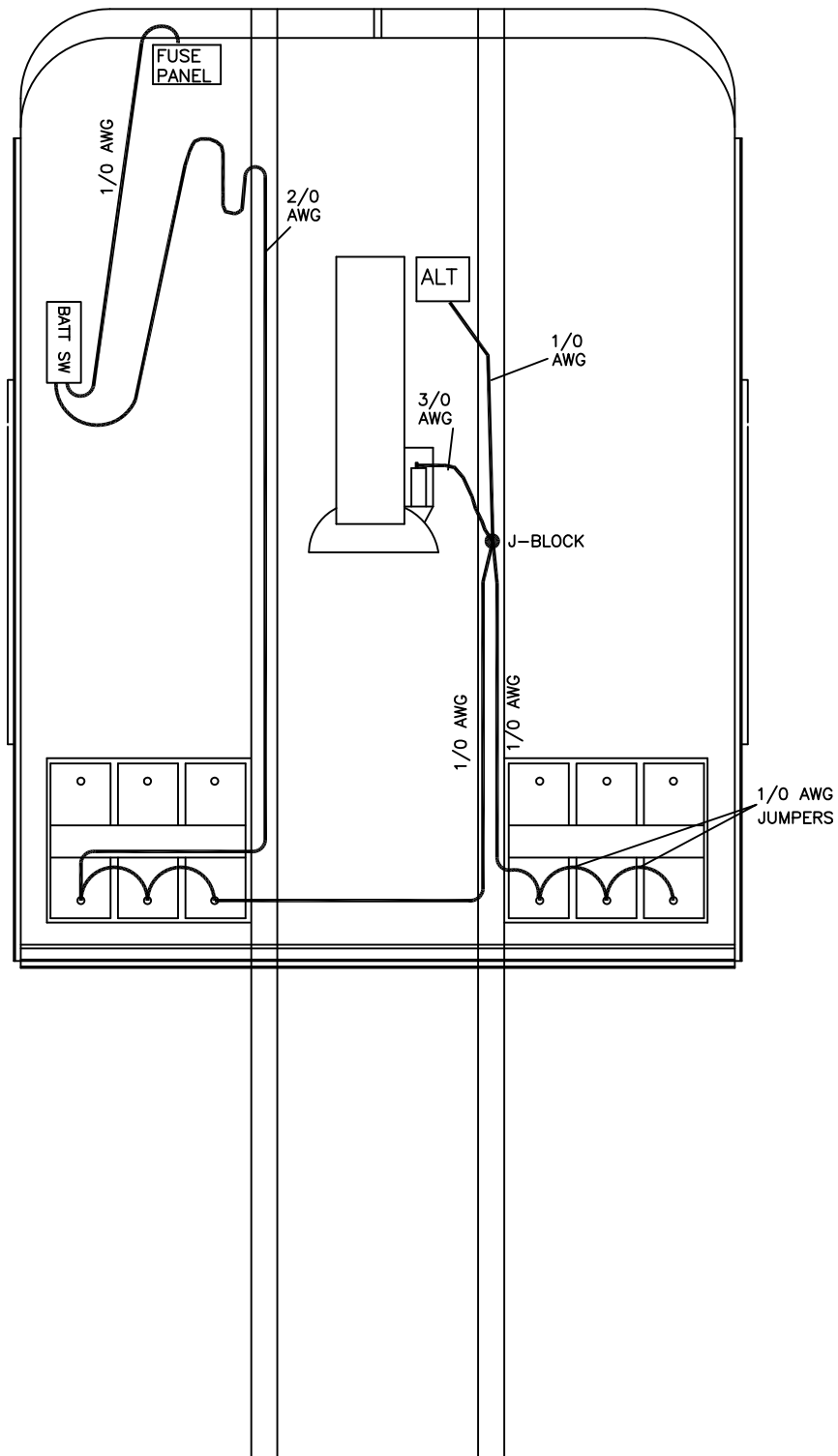

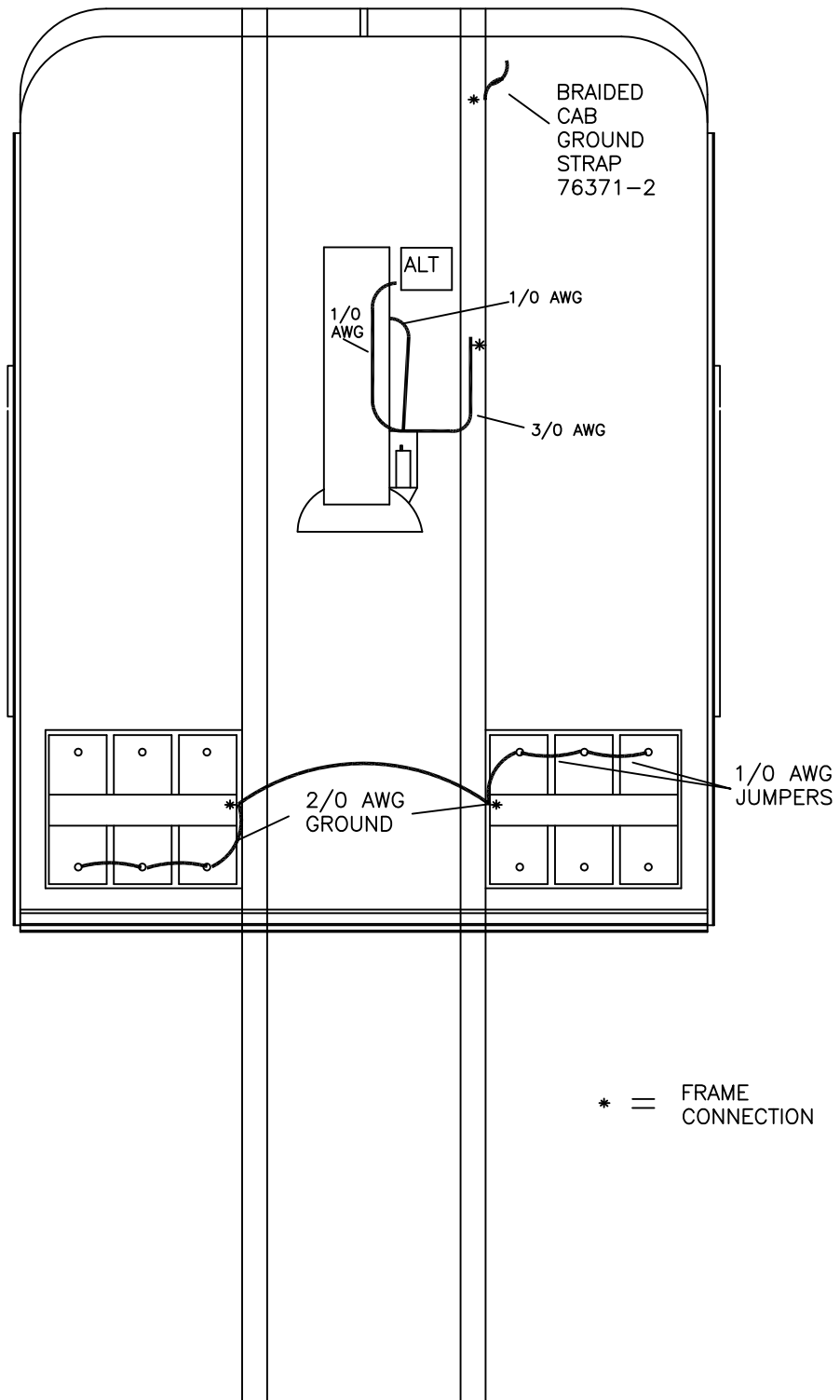

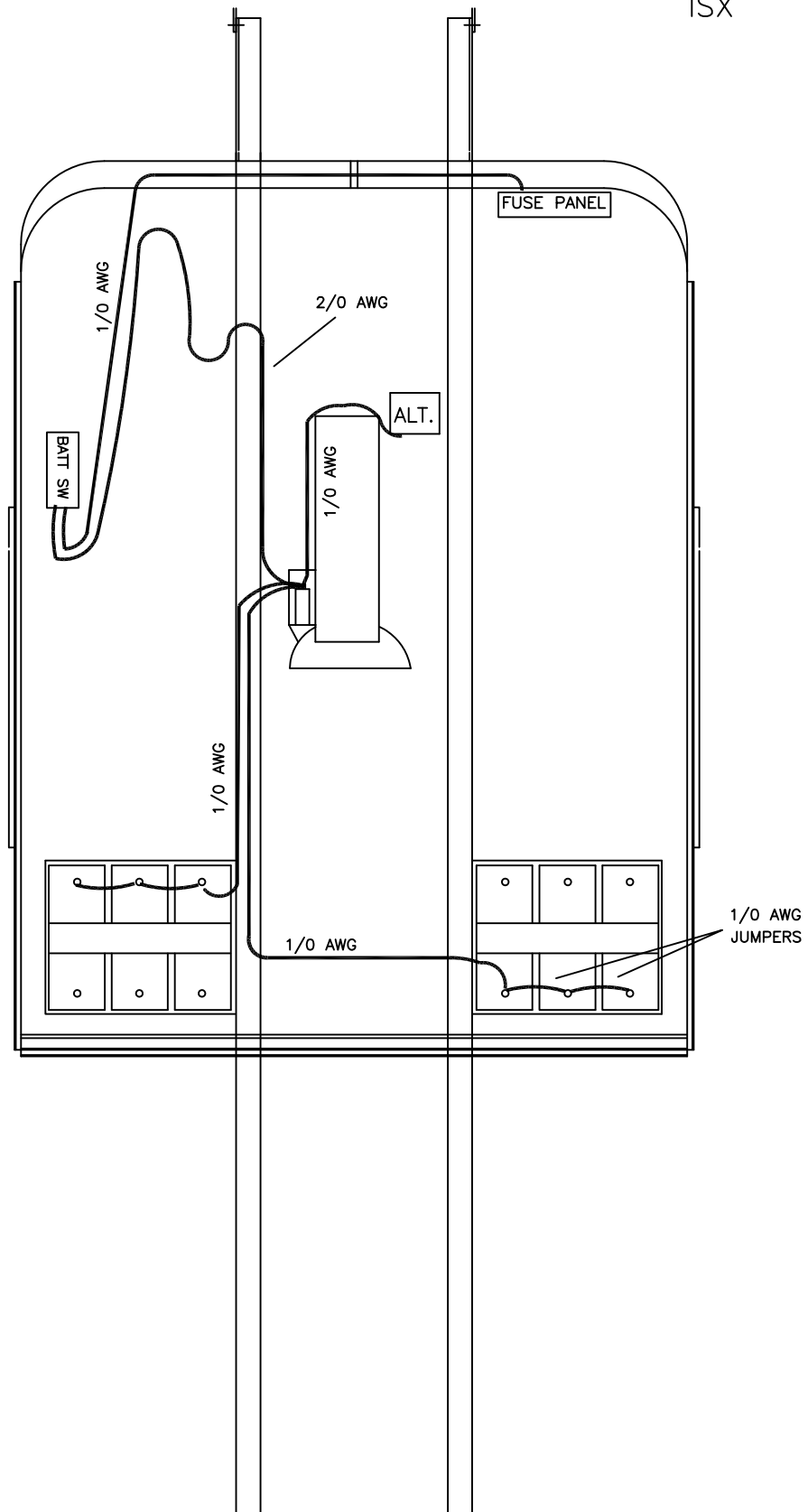

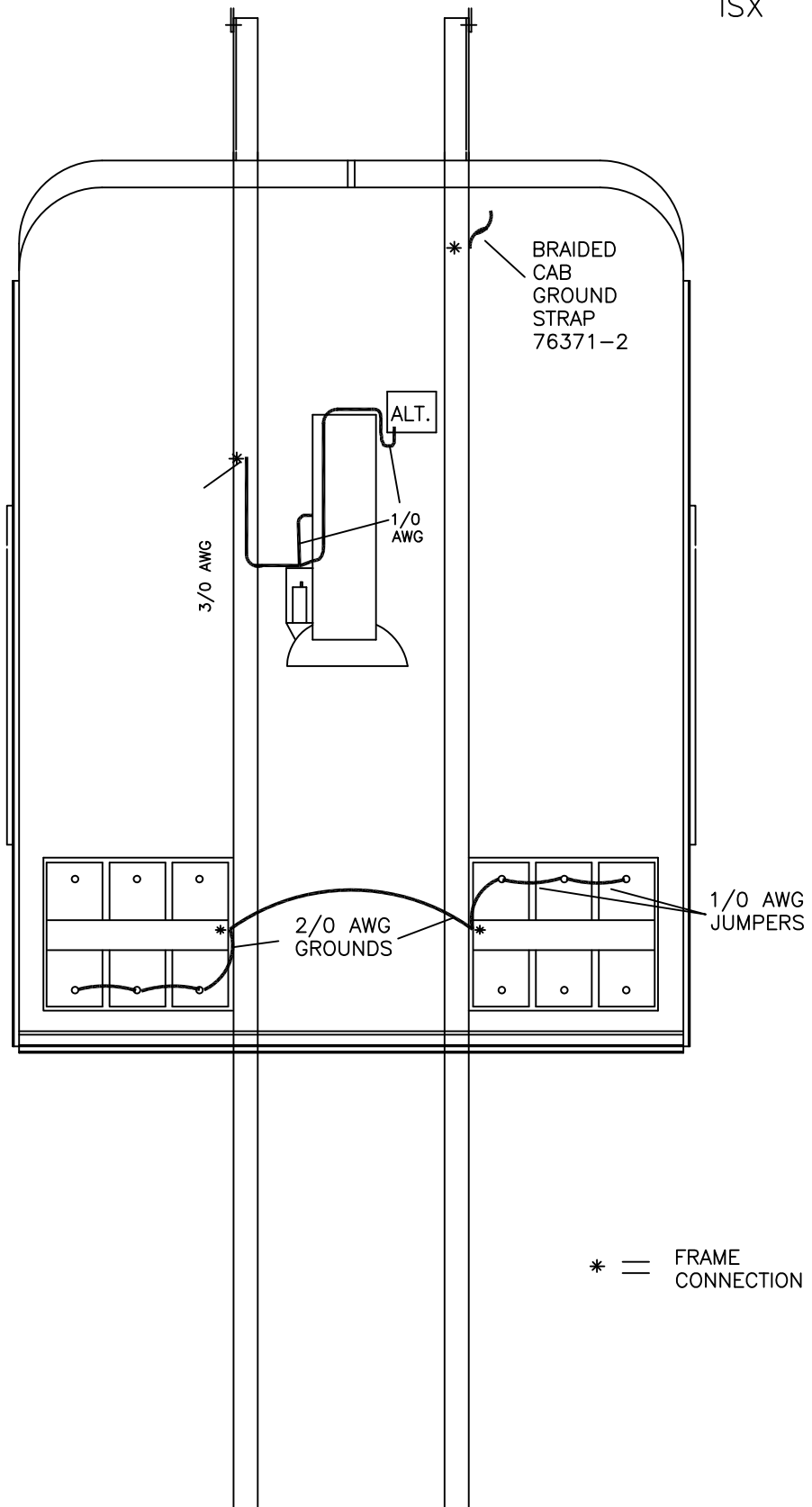

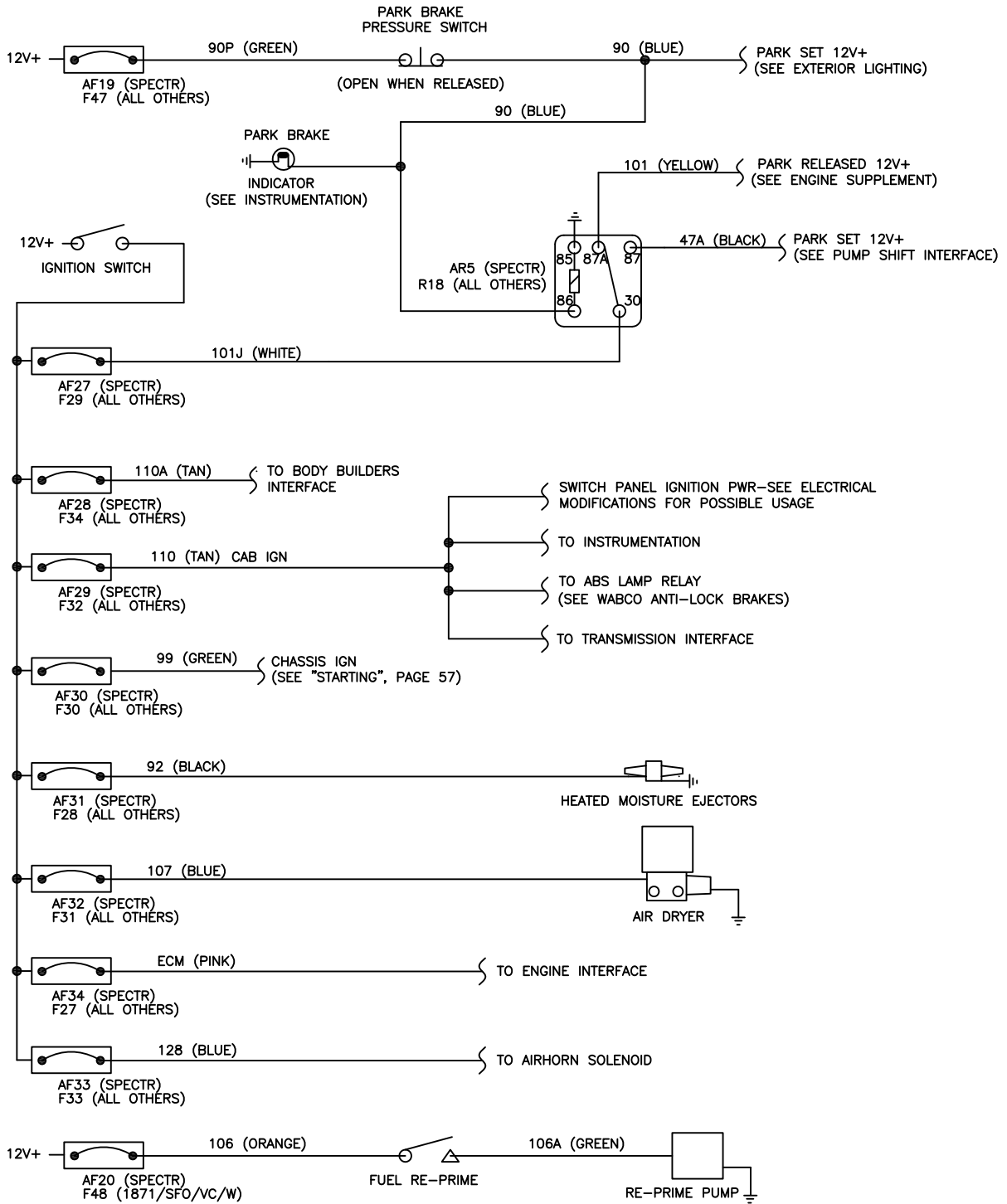

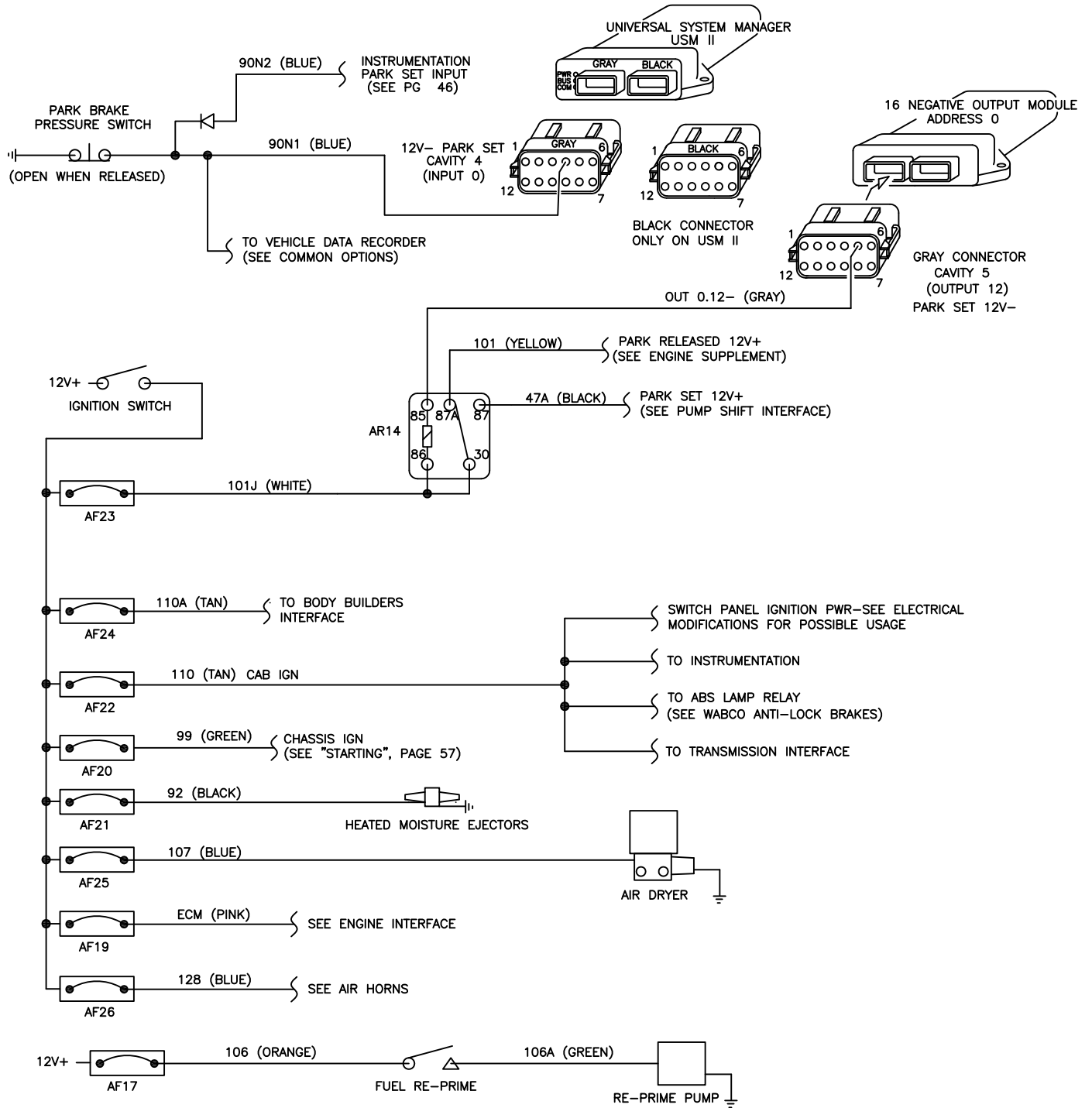

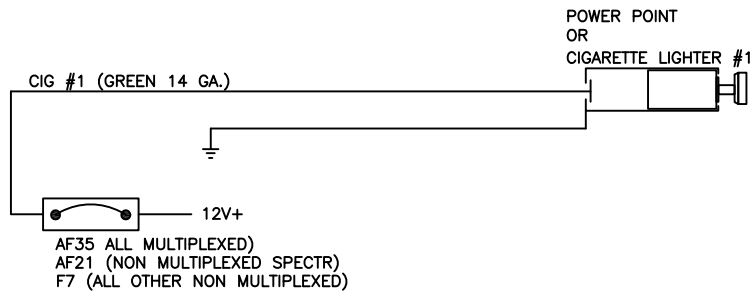
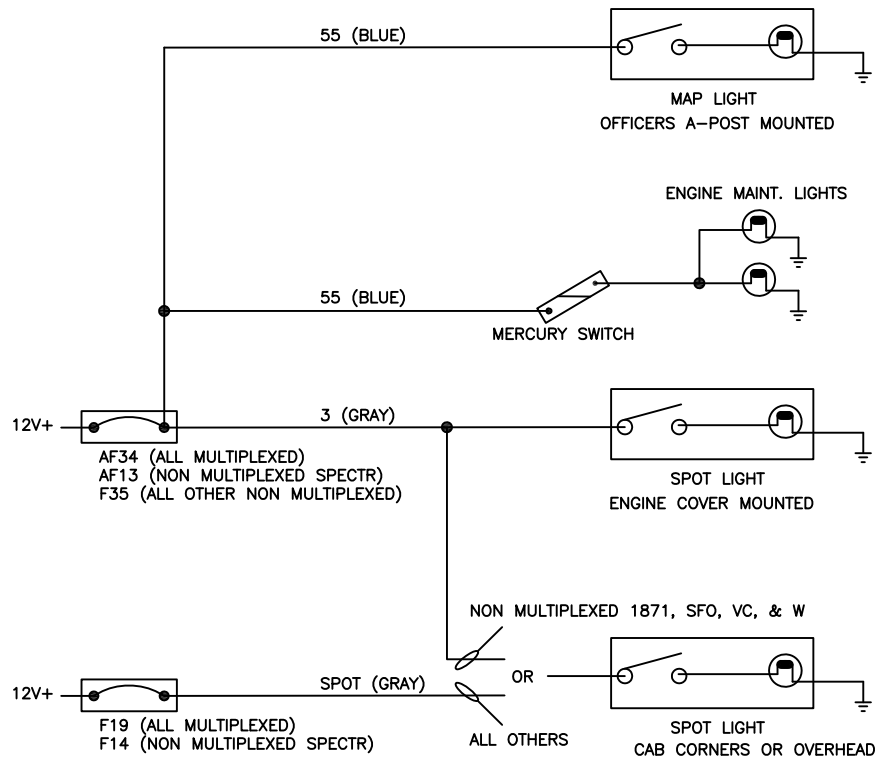

OPEN FOR FUTURE USE

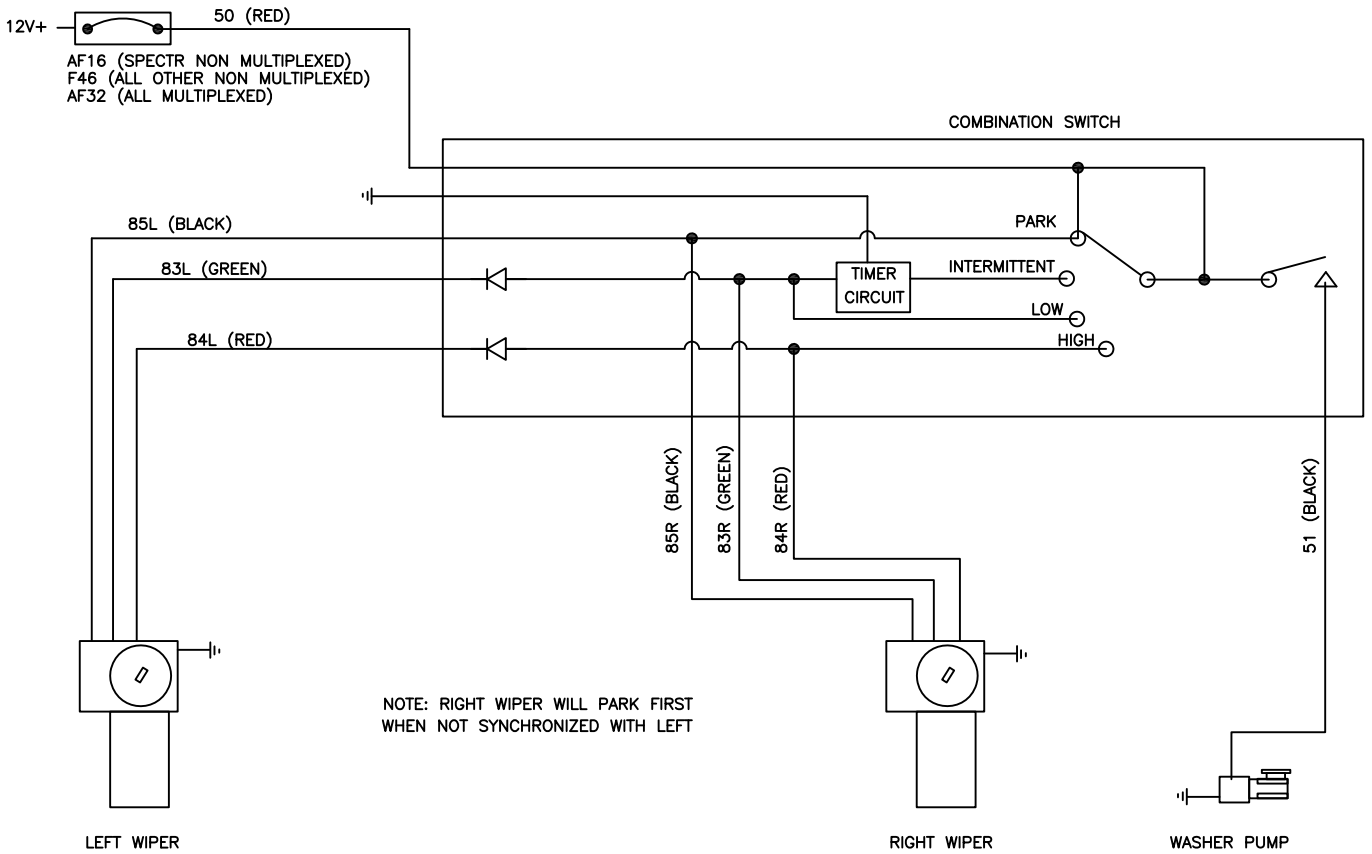

SCHEMATICS

WABCO ANTI-LOCK BRAKES
(BASIC OR WITH ROLL STABILITY CONTROL)

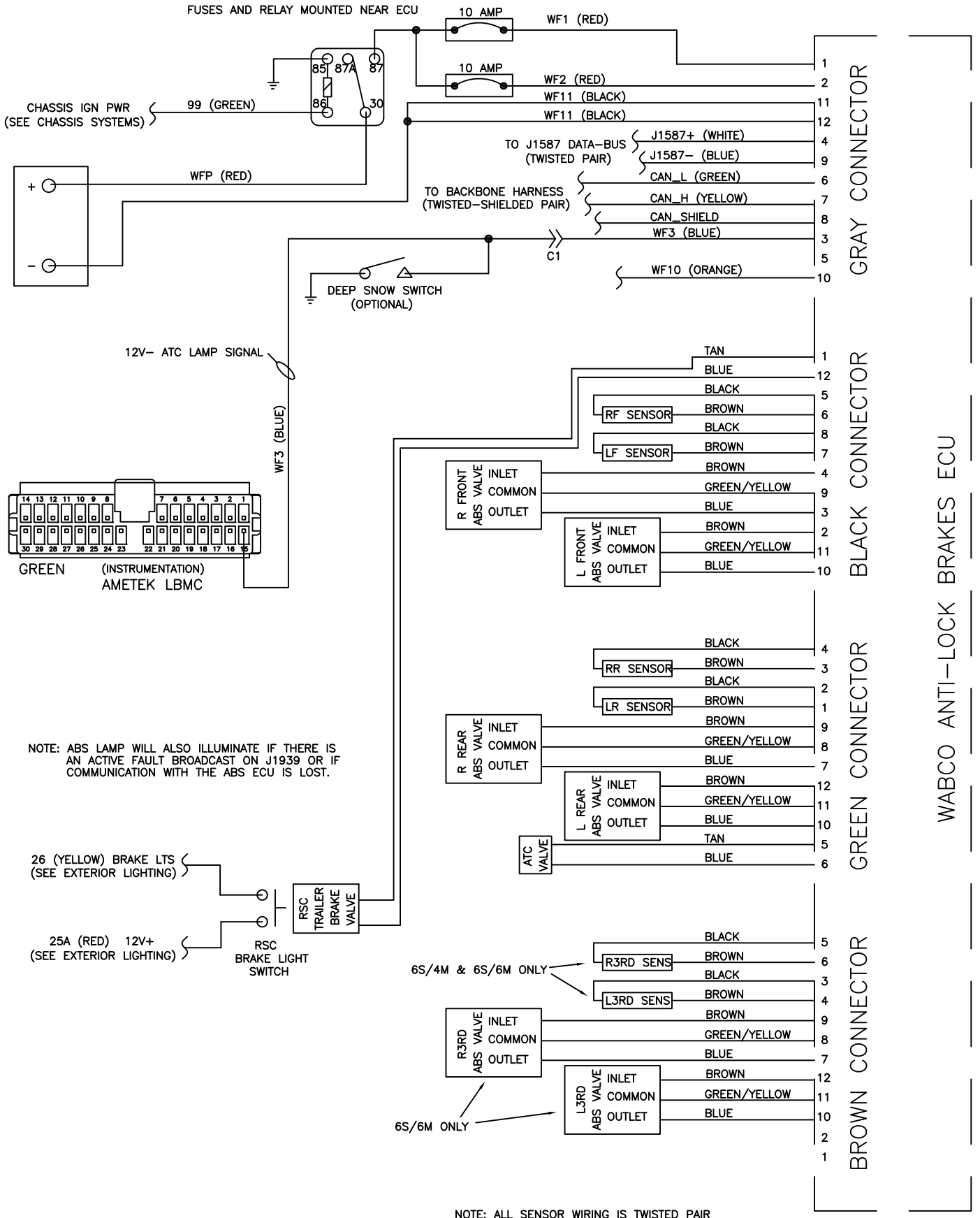

SCHEMATICS

WABCO ANTI-LOCK BRAKES (WITH ELECTRONIC STABILITY CONTROL)

FUSES AND RELAY MOUNTED NEAR ECU

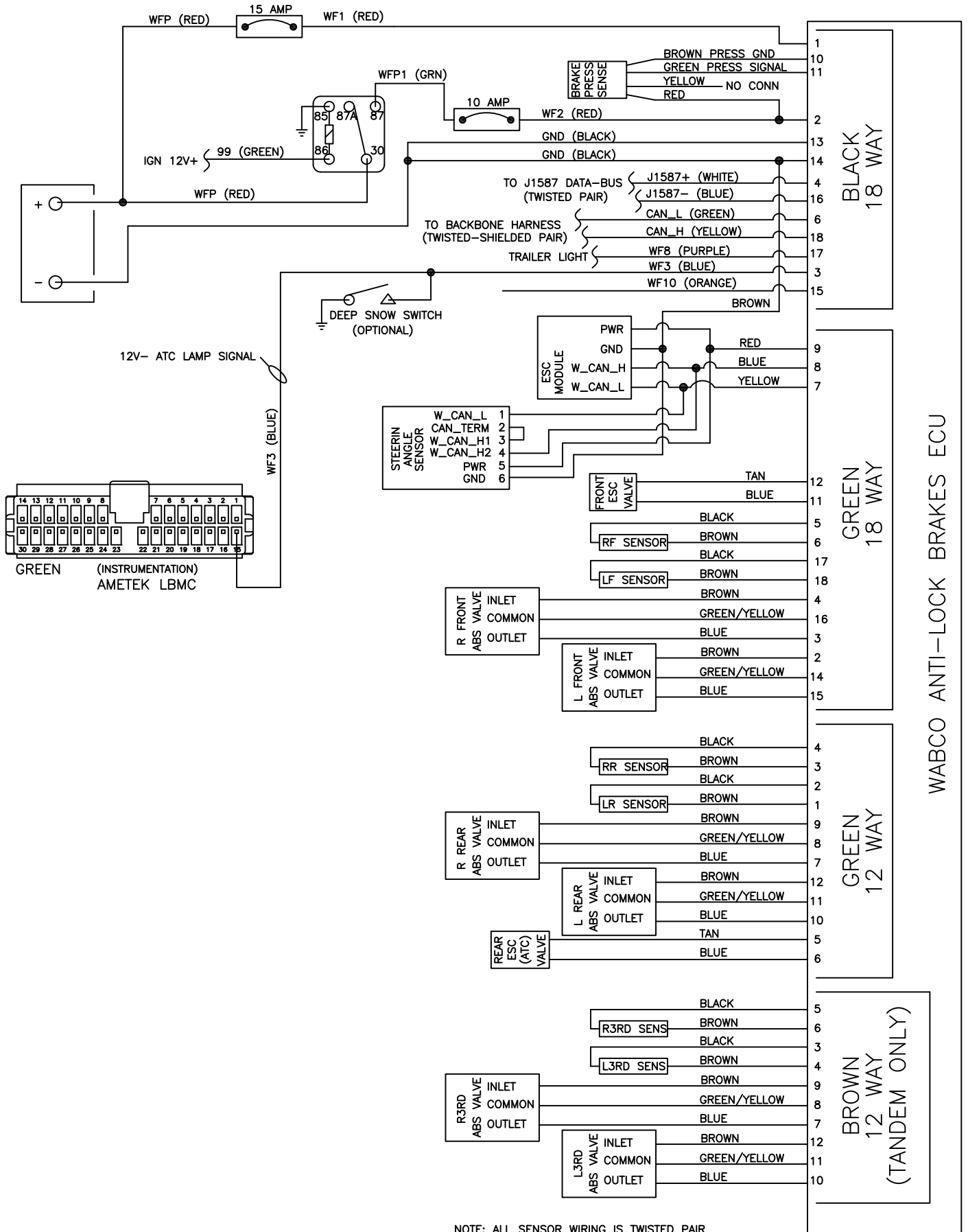

NOTE: ALL SENSOR WIRING IS TWISTED PAIR

CHANGE MADE TO ALL 2010 HARNESSSES
MARCH OF 2011

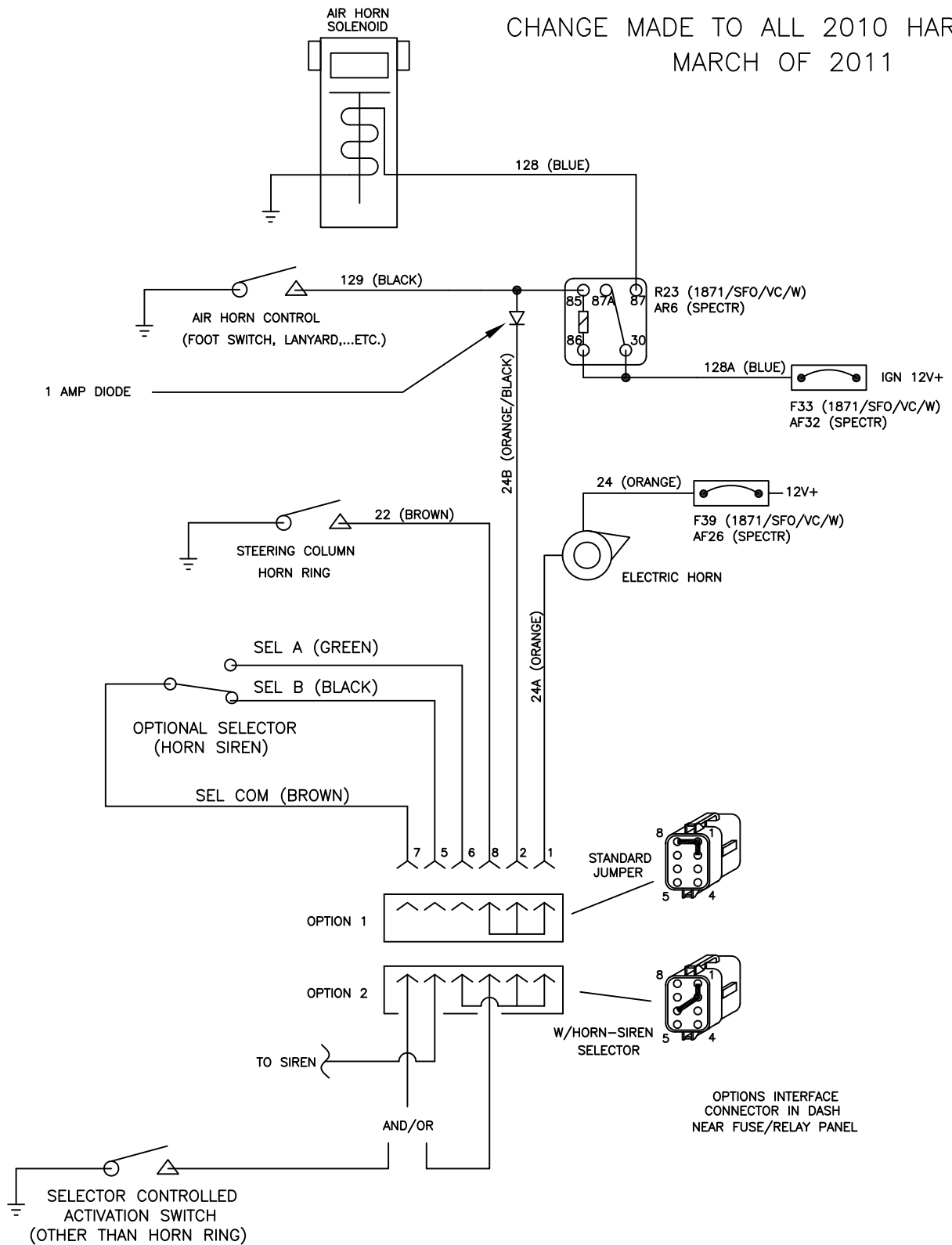

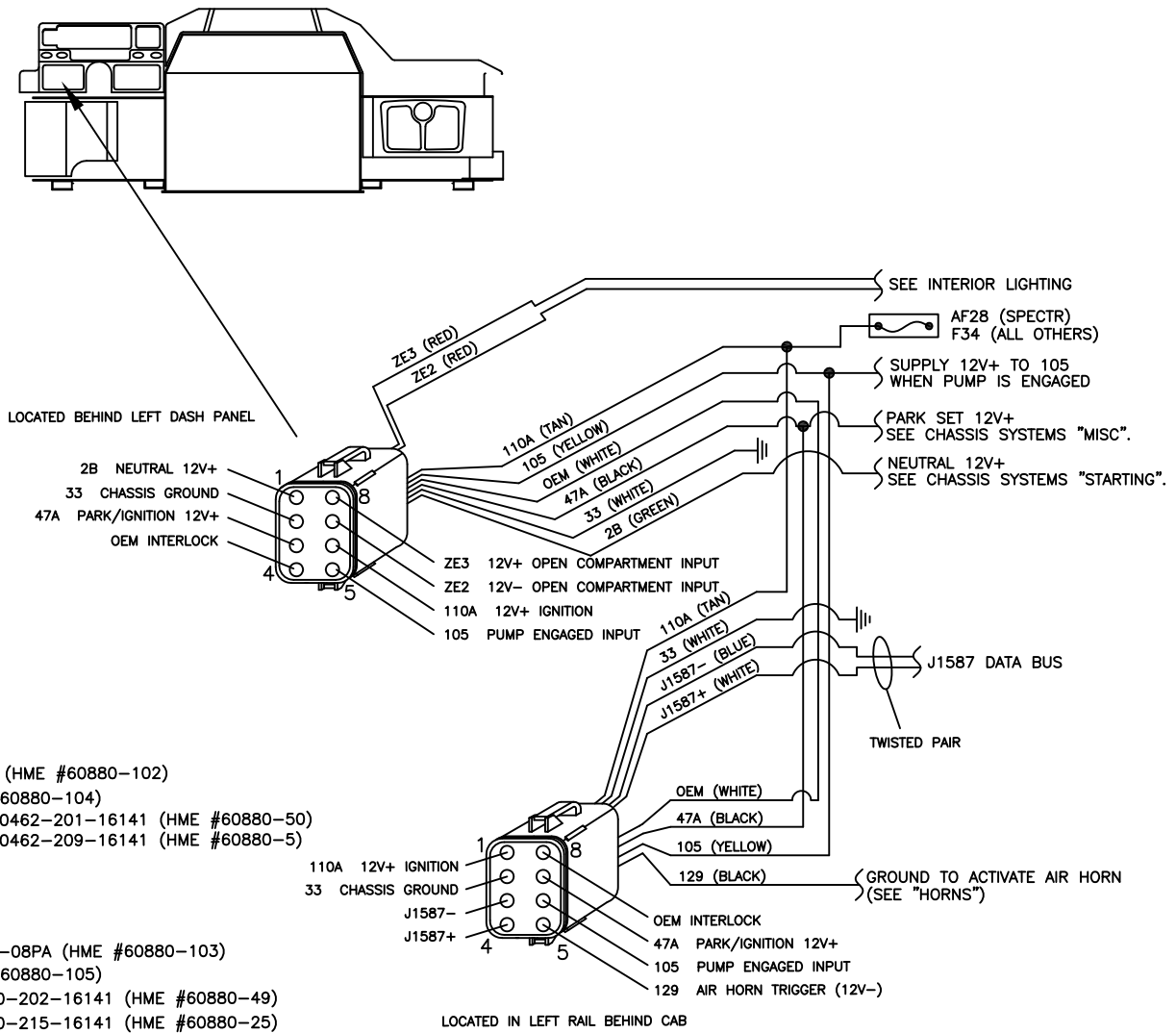

MATING CONNECTORS

IN CAB:
 DEUTSCH EIGHT WAY DT SERIES
 CONNECTOR, PLUG, #DT06-08SA (HME #60880-102)
 SECONDARY LOCK, #W8S (HME #60880-104)
 16-18 GA TERMINAL SOCKET, # 0462-201-16141 (HME #60880-50)
 14-16 GA TERMINAL SOCKET, # 0462-209-16141 (HME #60880-5)

BEHIND CAB:
 DEUTSCH EIGHT WAY DT SERIES
 CONNECTOR, RECEPTACLE, #DT04-08PA (HME #60880-103)
 SECONDARY LOCK, #W8P (HME #60880-105)
 16-18 GA TERMINAL PIN, # 0460-202-16141 (HME #60880-49)
 14-16 GA TERMINAL PIN, # 0460-215-16141 (HME #60880-25)

CHASSIS GROUNDS ARE PROVIDED FOR USE IN GROUNDING RELAY COILS OR SMALL INDICATOR LAMPS ONLY. CURRENT FLOW SHOULD NOT EXCEED 4 AMPS THROUGH EITHER OF THESE GROUND CONNECTIONS.

ATTENTION BODY BUILDER

WHILE THIS INTERFACE IS PROVIDED FOR YOUR CONVENIENCE IT IS YOUR RESPONSIBILITY TO PROVIDE THE PROPER WIRING NECESSARY FOR THE REQUIREMENTS OF YOUR APPLICATION. THIS INCLUDES MEETING ANY NFPA OR OTHER APPLICABLE GUIDELINES. SEE ALLISON SUPPLEMENT FOR PUMP SHIFT AND PTO WIRING INTERFACE. SEE ENGINE SUPPLEMENT FOR REMOTE ACCELERATOR WIRING INTERFACE.

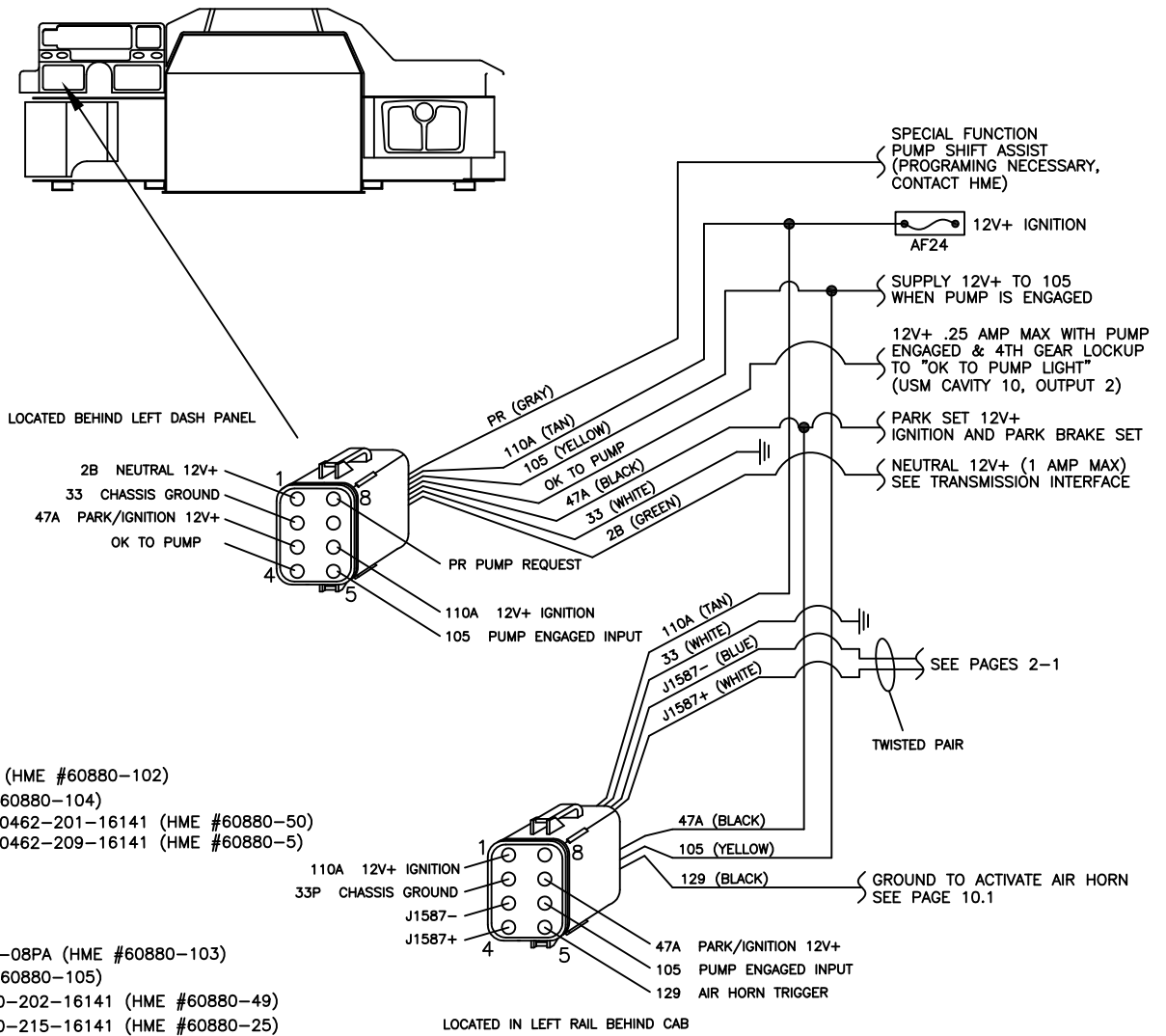

MATING CONNECTORS

IN CAB:
DEUTSCH EIGHT WAY DT SERIES
CONNECTOR, PLUG, #DT06-08SA (HME #60880-102)
SECONDARY LOCK, #W8S (HME #60880-104)
16-18 GA TERMINAL SOCKET, # 0462-201-16141 (HME #60880-50)
14-16 GA TERMINAL SOCKET, # 0462-209-16141 (HME #60880-5)

BEHIND CAB:
DEUTSCH EIGHT WAY DT SERIES
CONNECTOR, RECEPTACLE, #DT04-08PA (HME #60880-103)
SECONDARY LOCK, #W8P (HME #60880-105)
16-18 GA TERMINAL PIN, # 0460-202-16141 (HME #60880-49)
14-16 GA TERMINAL PIN, # 0460-215-16141 (HME #60880-25)

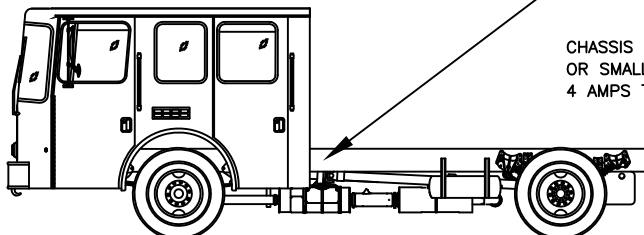

ATTENTION BODY BUILDER

WHILE THIS INTERFACE IS PROVIDED FOR YOUR CONVENIENCE IT IS YOUR RESPONSIBILITY TO PROVIDE THE PROPER WIRING NECESSARY FOR THE REQUIREMENTS OF YOUR APPLICATION. THIS INCLUDES MEETING ANY NFPA OR OTHER APPLICABLE GUIDELINES. SEE ALLISON SUPPLEMENT FOR PUMP SHIFT AND PTO WIRING INTERFACE. SEE ENGINE SUPPLEMENT FOR REMOTE ACCELERATOR WIRING INTERFACE.

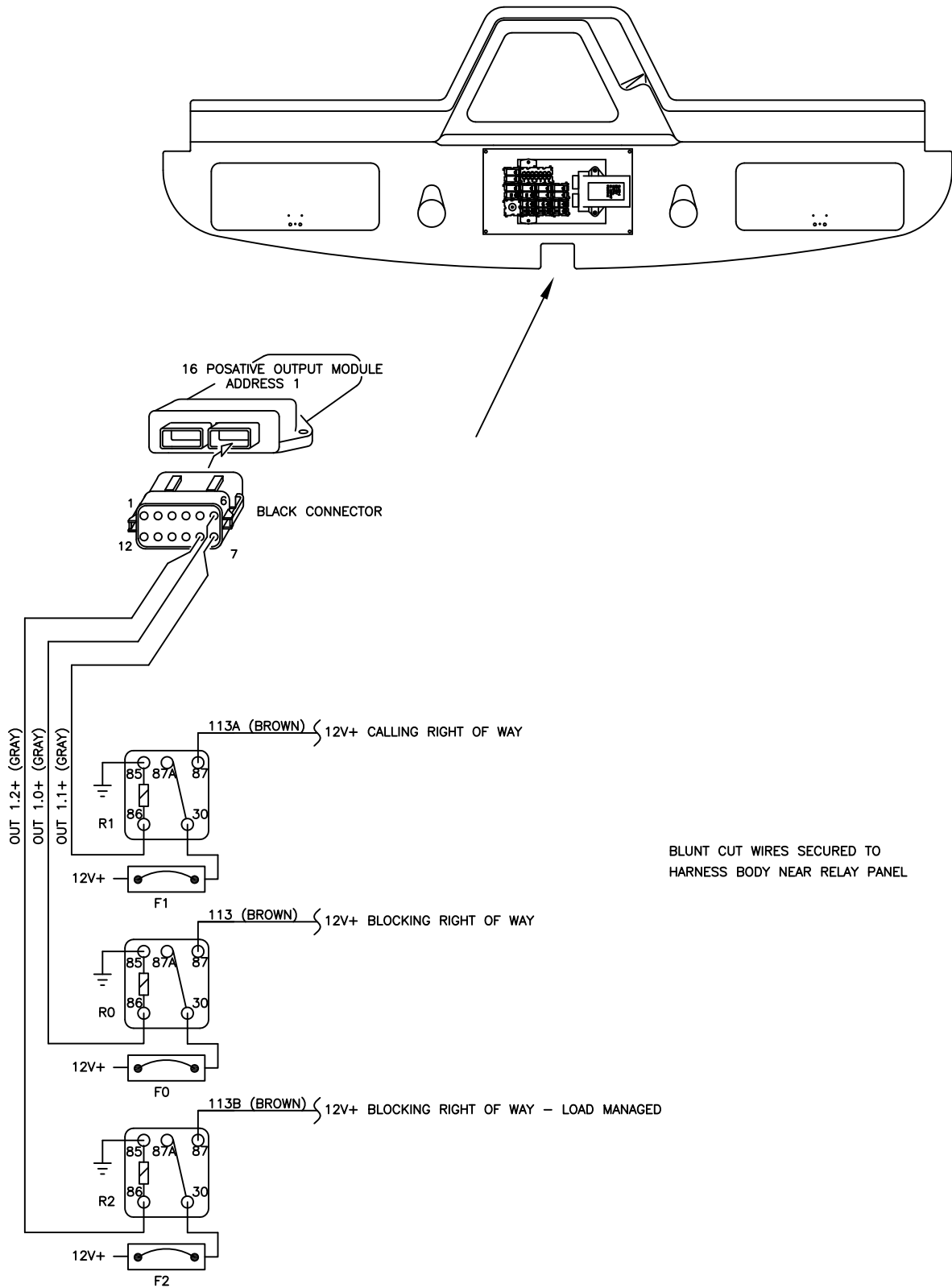

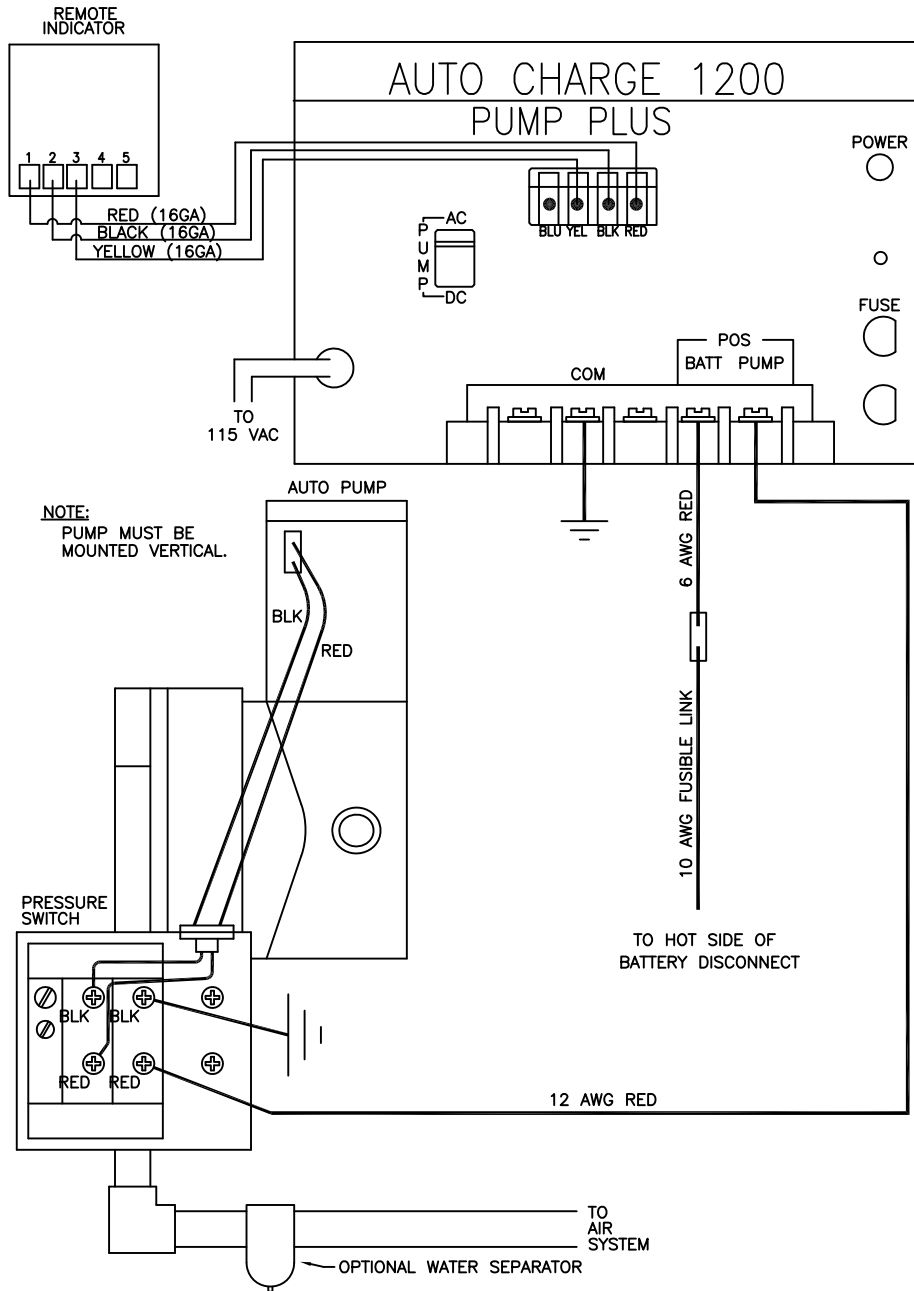

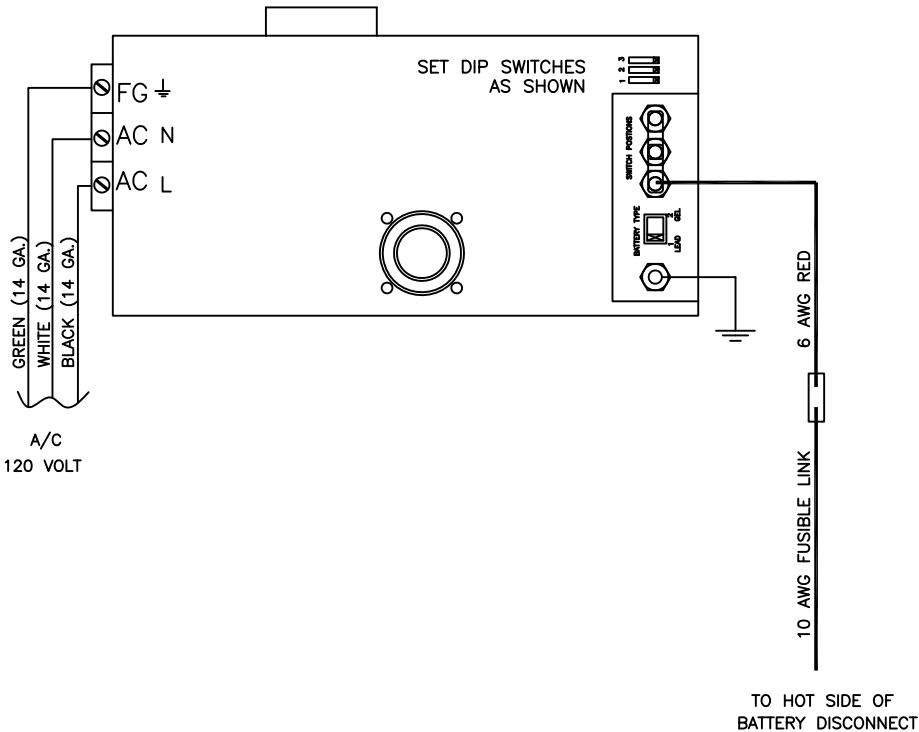

COMMON OPTIONS

EMERGENCY SPRING
BRAKE RELEASE

PARKING BRAKE VALVE

EMERGENCY SPRING BRAKE
RELEASE VALVE

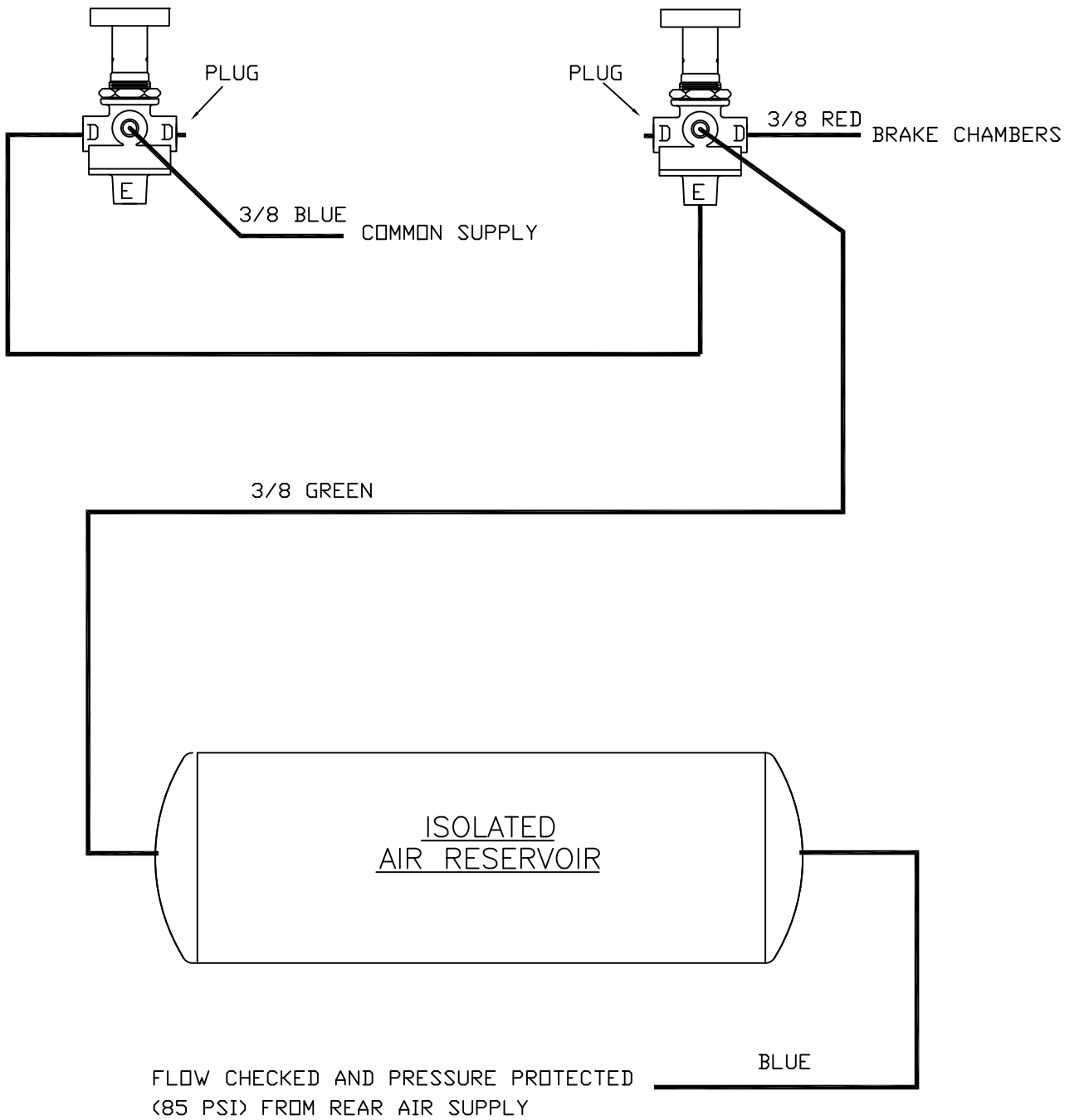

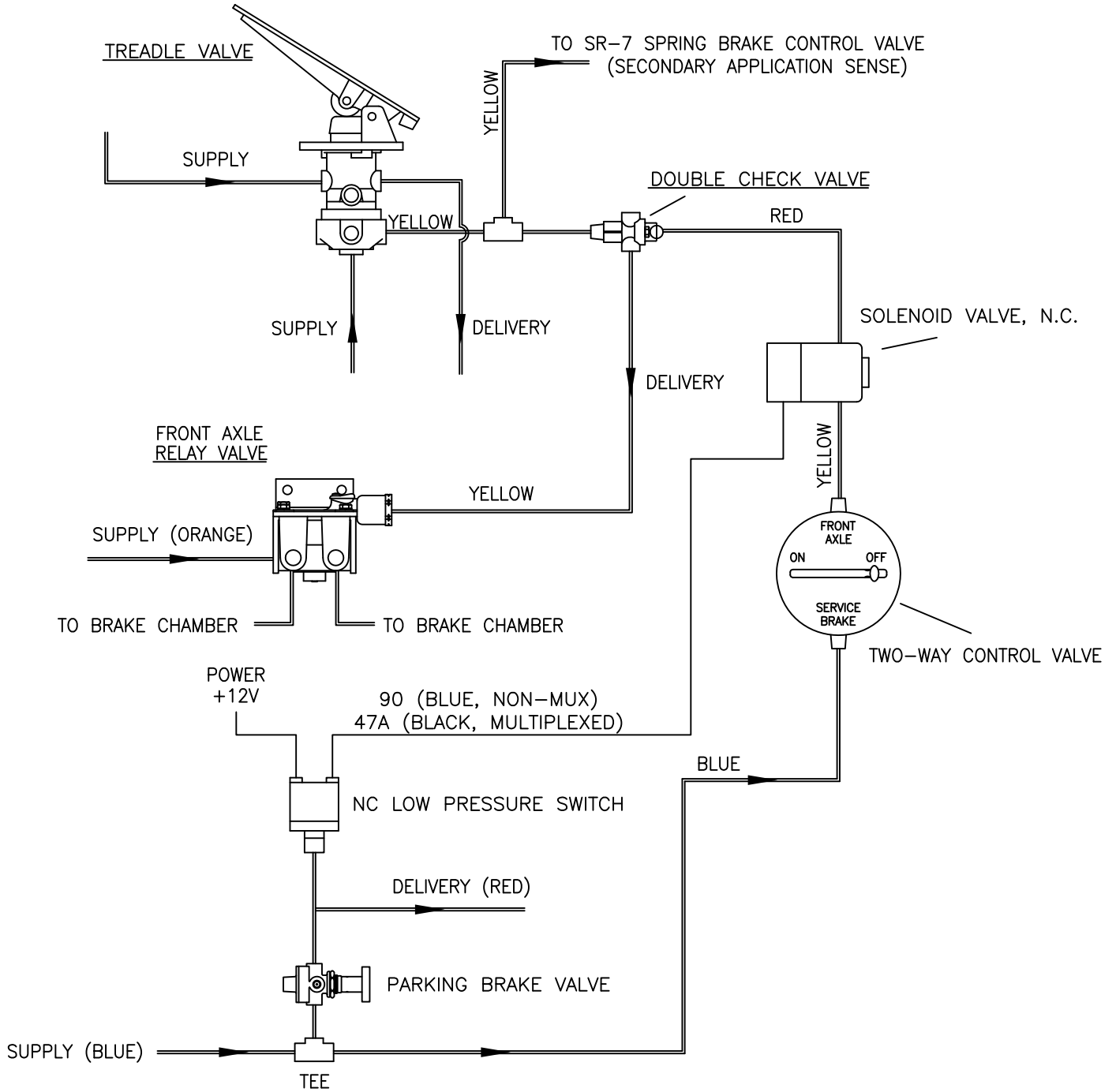

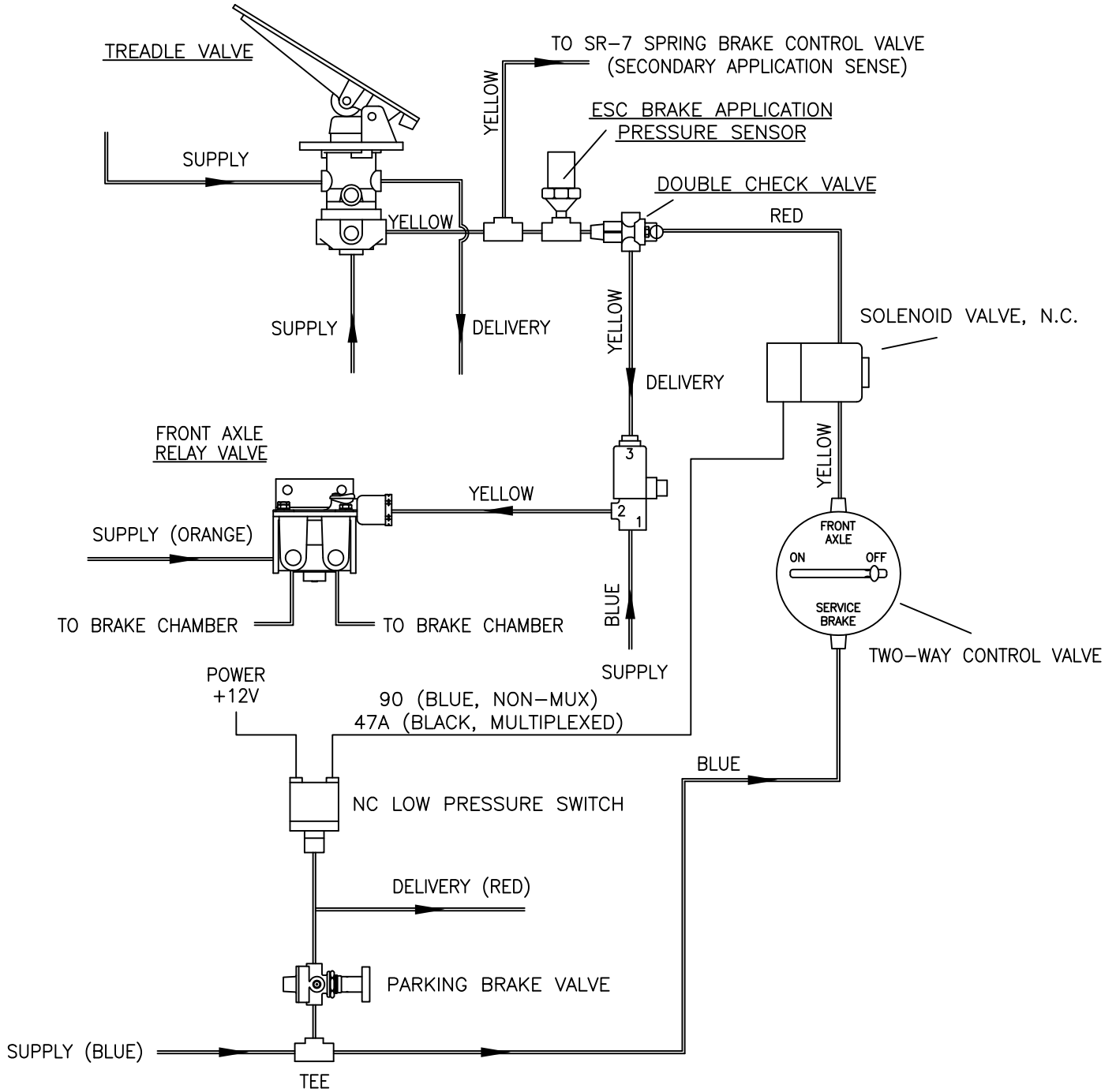

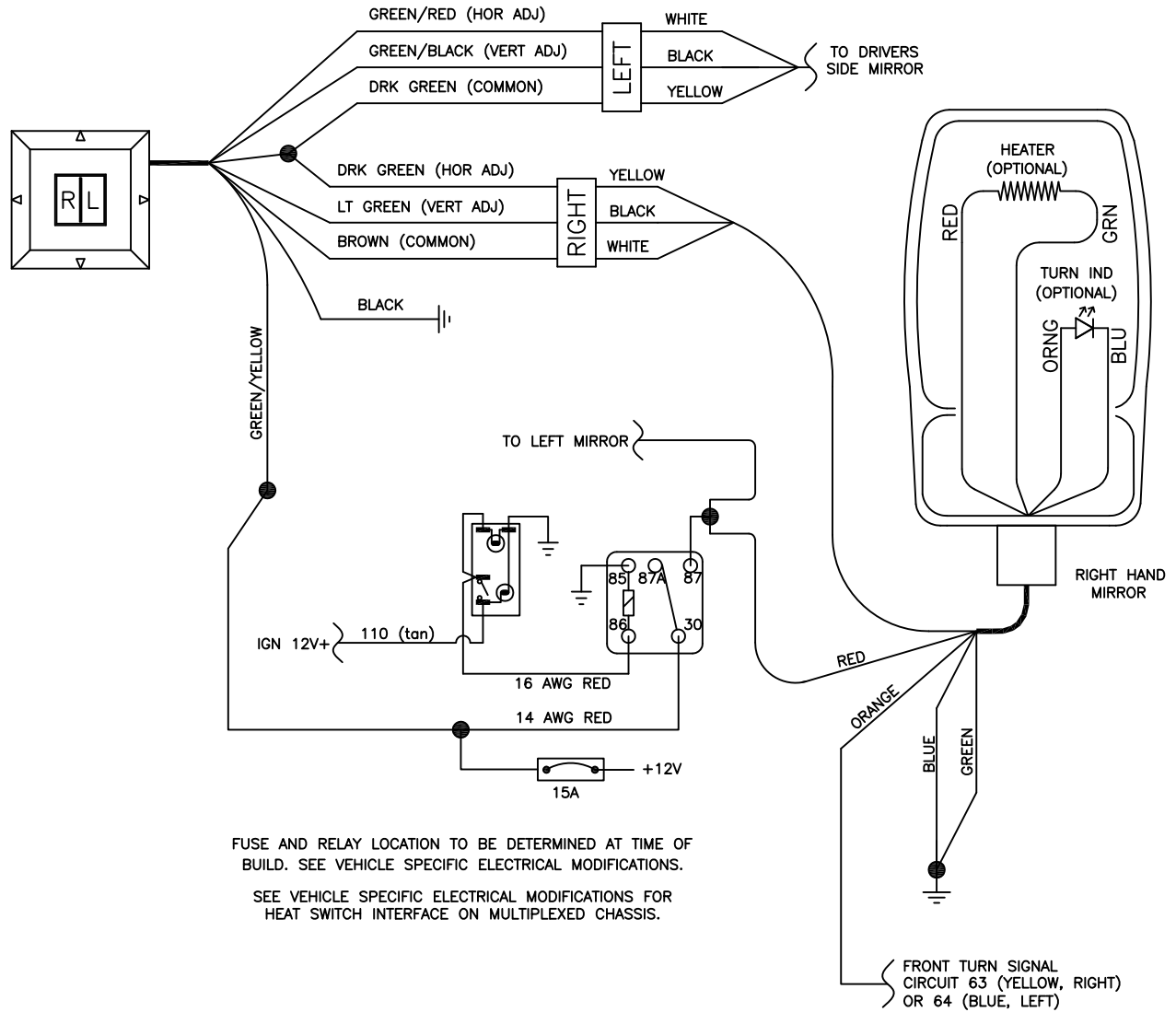

RIGHT HAND POWER ONLY IS STANDARD.
MIRROR HEAT, EMBEDDED TURN INDICATORS, AND LEFT HAND POWER ADJUST ARE ALL OPTIONS.

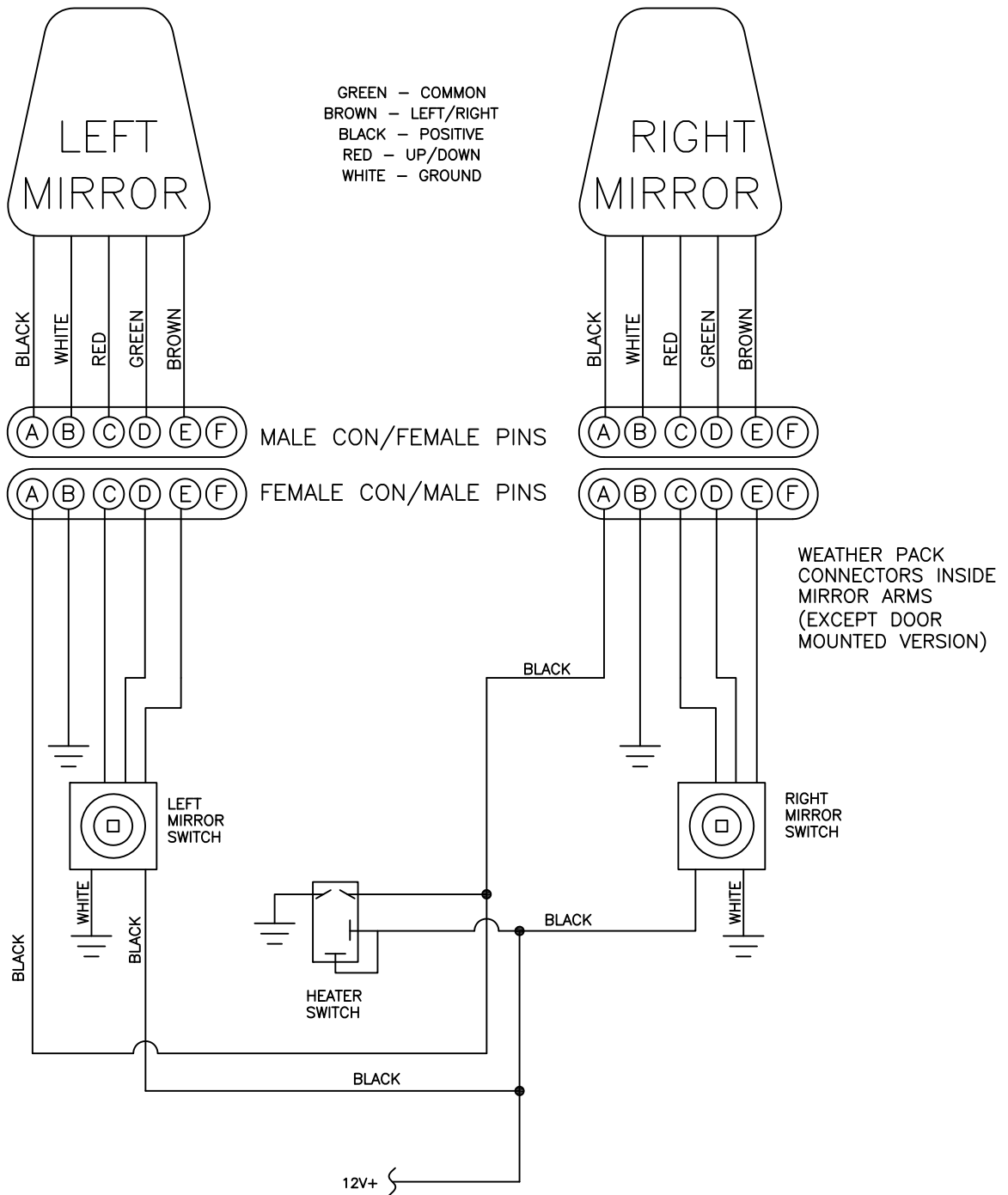

(10 AMP SOURCE TO BE DETERMINED AT TIME OF BUILD, SEE VEHICLE SPECIFIC ELECTRICAL MODIFICATIONS PAMPHLET.)

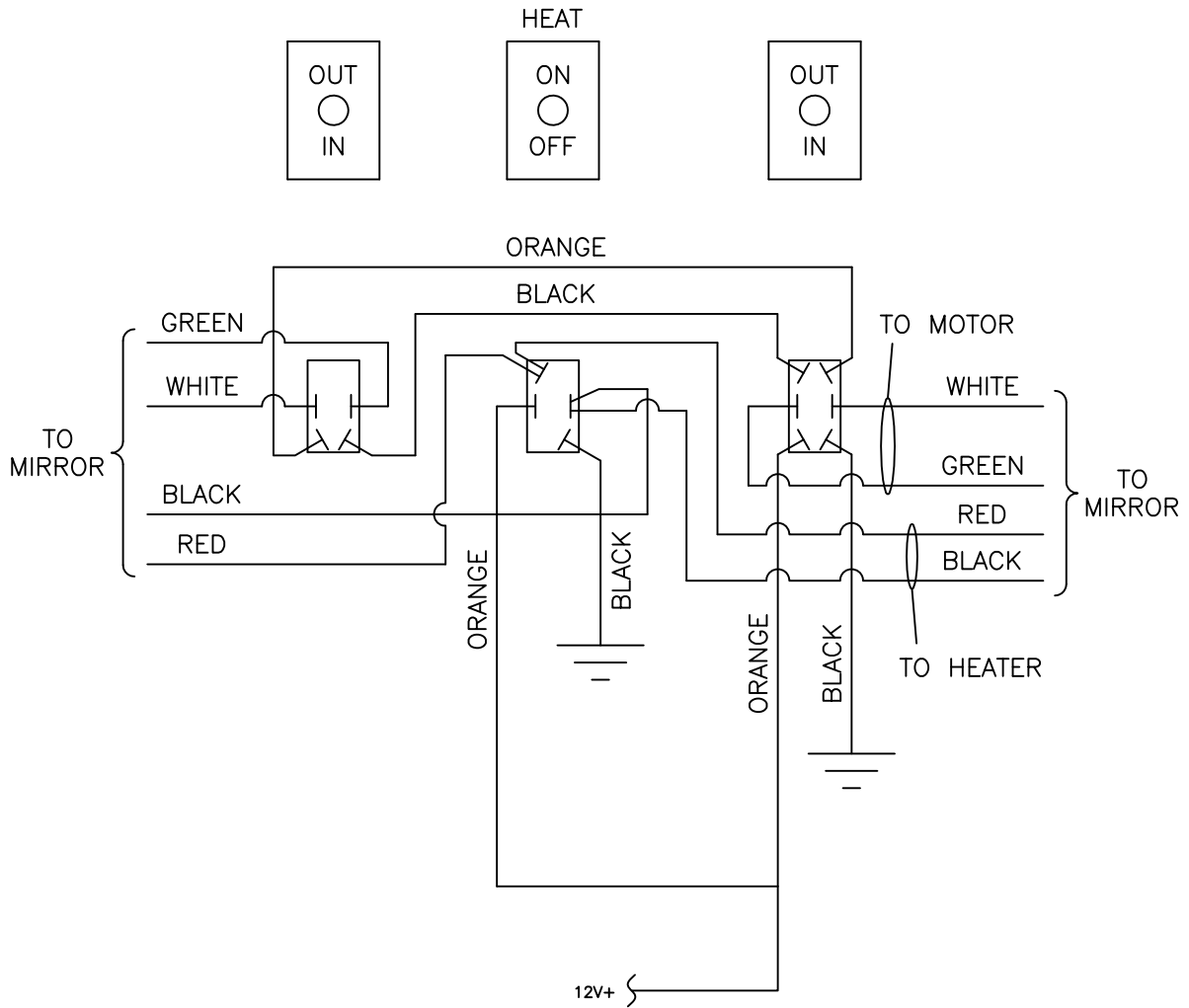

(10 AMP SOURCE TO BE DETERMINED AT TIME OF BUILD, SEE VEHICLE SPECIFIC ELECTRICAL MODIFICATIONS PAMPHLET.)

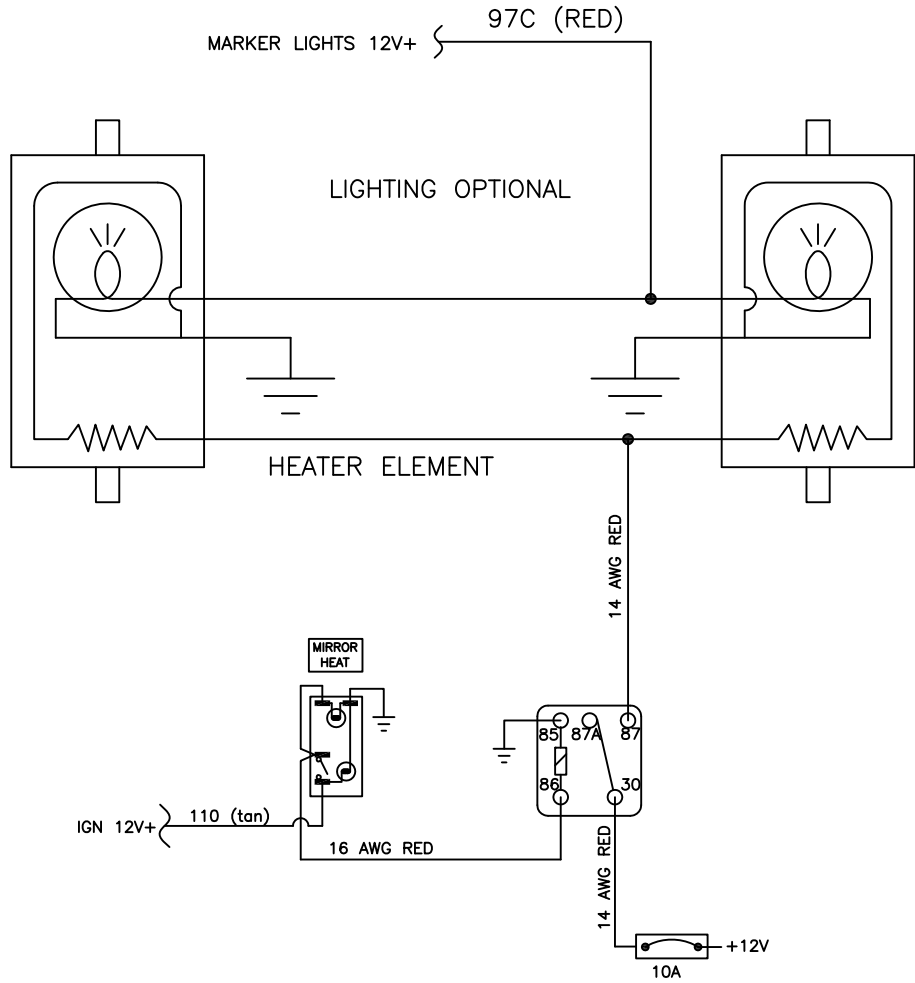

FUSE AND RELAY LOCATION TO BE DETERMINED AT TIME OF BUILD. SEE VEHICLE SPECIFIC ELECTRICAL MODIFICATIONS.

SEE VEHICLE SPECIFIC ELECTRICAL MODIFICATIONS FOR HEAT SWITCH INTERFACE ON MULTIPLEXED CHASSIS.

EMITTER MODEL 792H

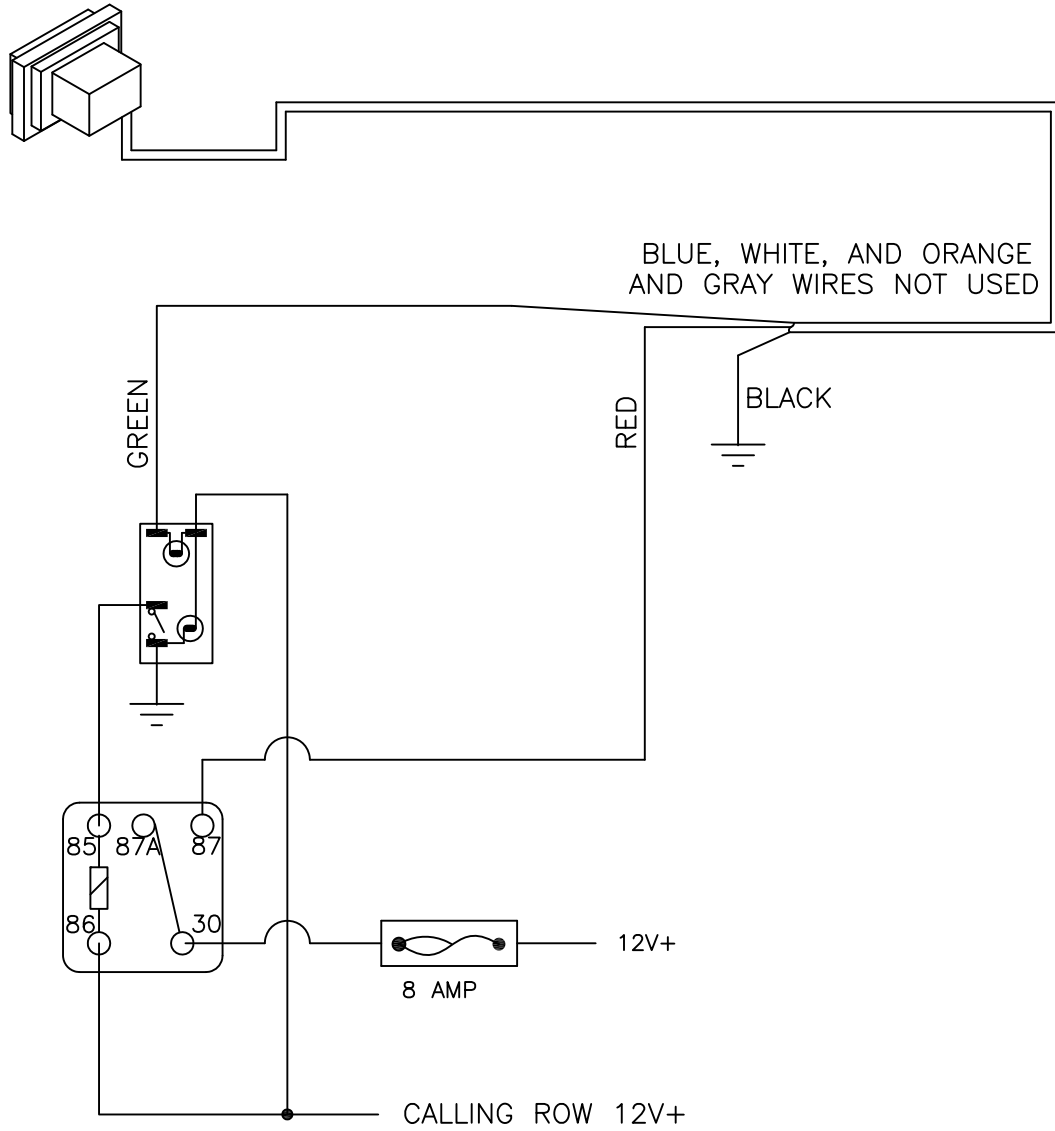

FUSE AND RELAY LOCATION TO BE DETERMINED AT TIME OF BUILD. SEE VEHICLE SPECIFIC ELECTRICAL MODIFICATIONS.

SEE VEHICLE SPECIFIC ELECTRICAL MODIFICATIONS FOR INTERFACE ON MULTIPLEXED CHASSIS.

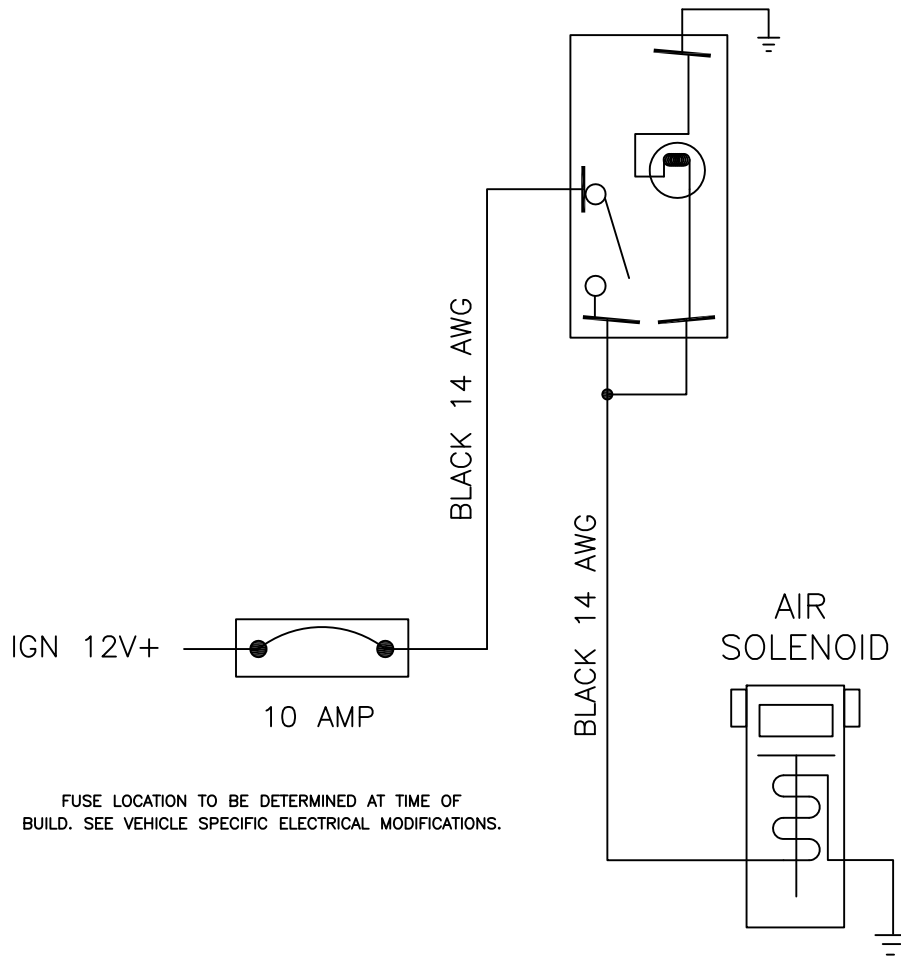

NOTE: RUDD BRAND TIRE CHAINS USE AN UNLIGHTED SWITCH

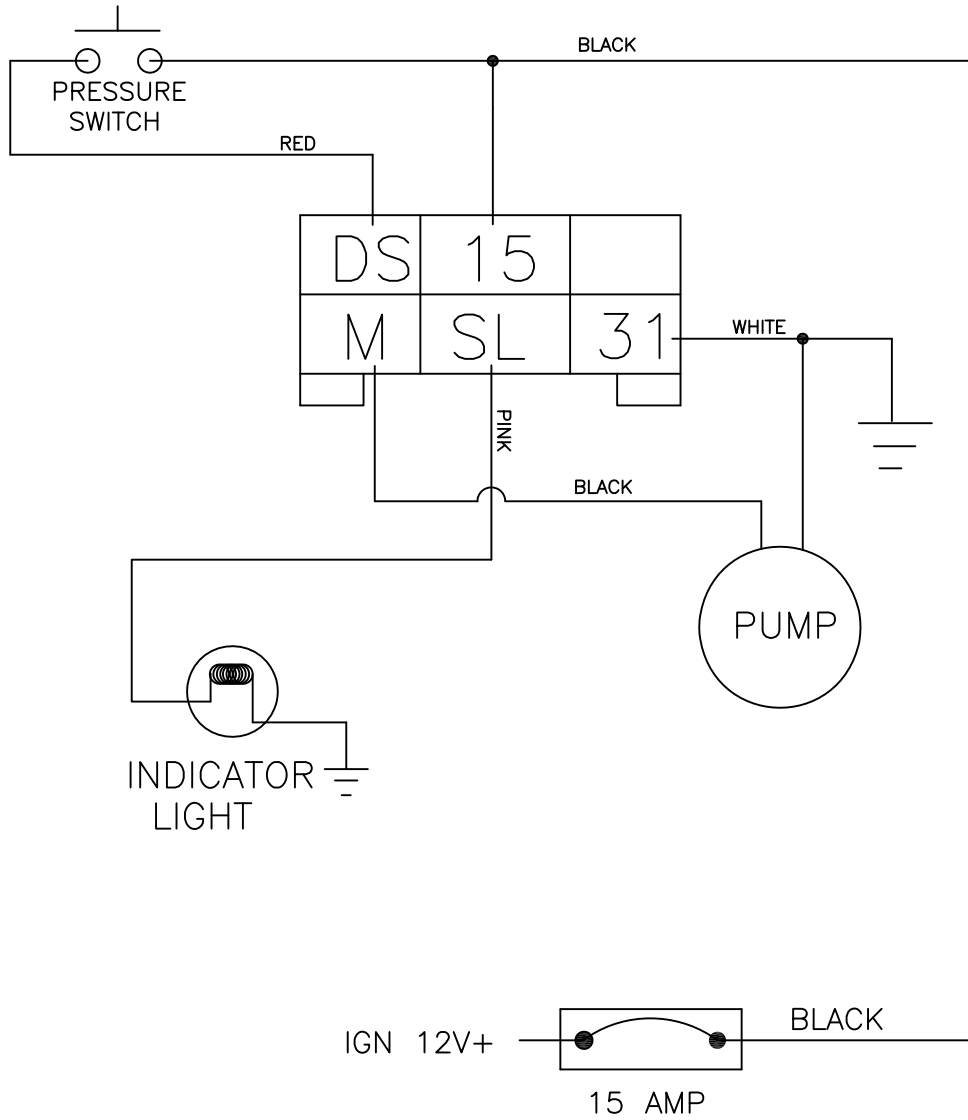

FUSE LOCATION TO BE DETERMINED AT TIME OF
BUILD. SEE VEHICLE SPECIFIC ELECTRICAL MODIFICATIONS.

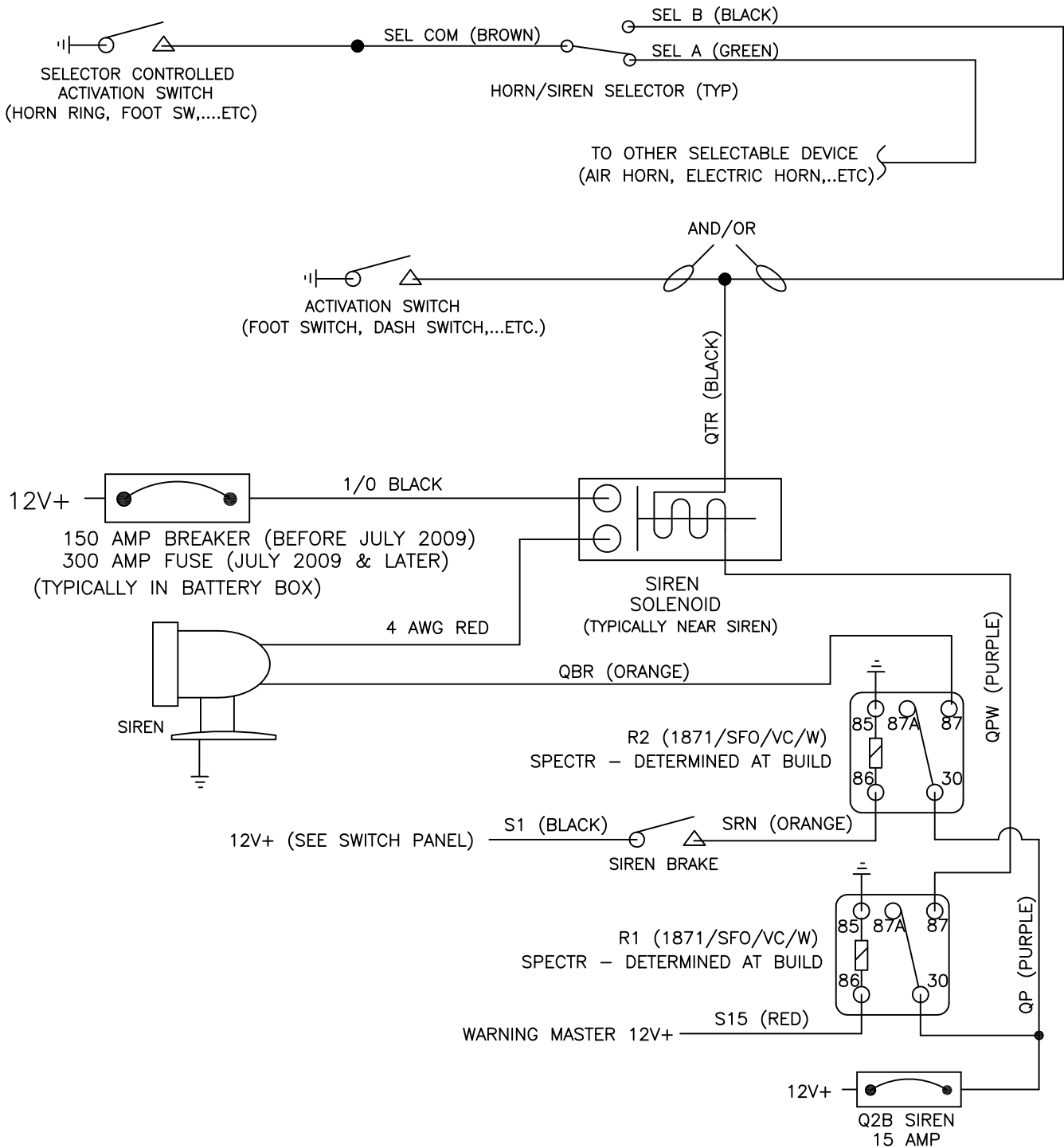

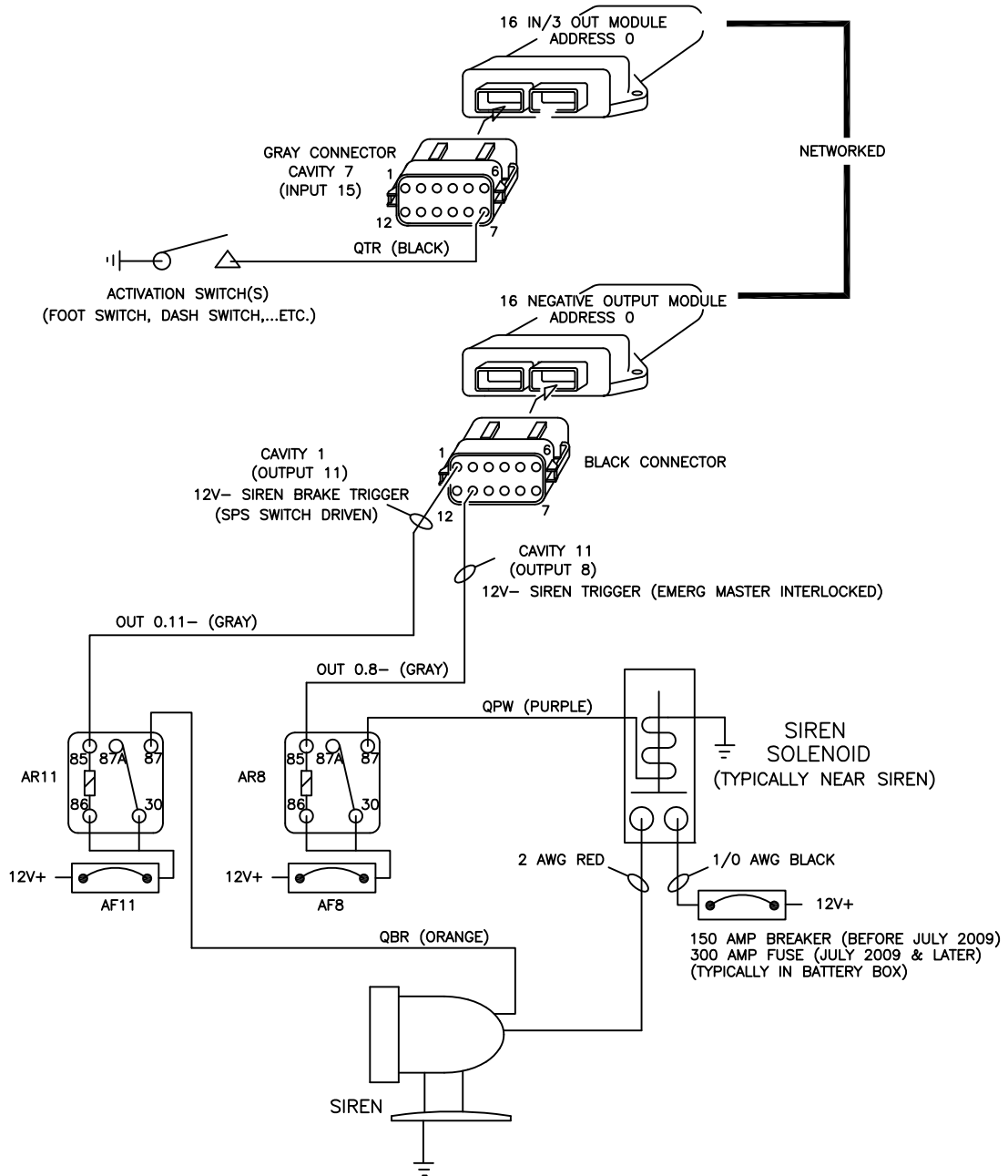

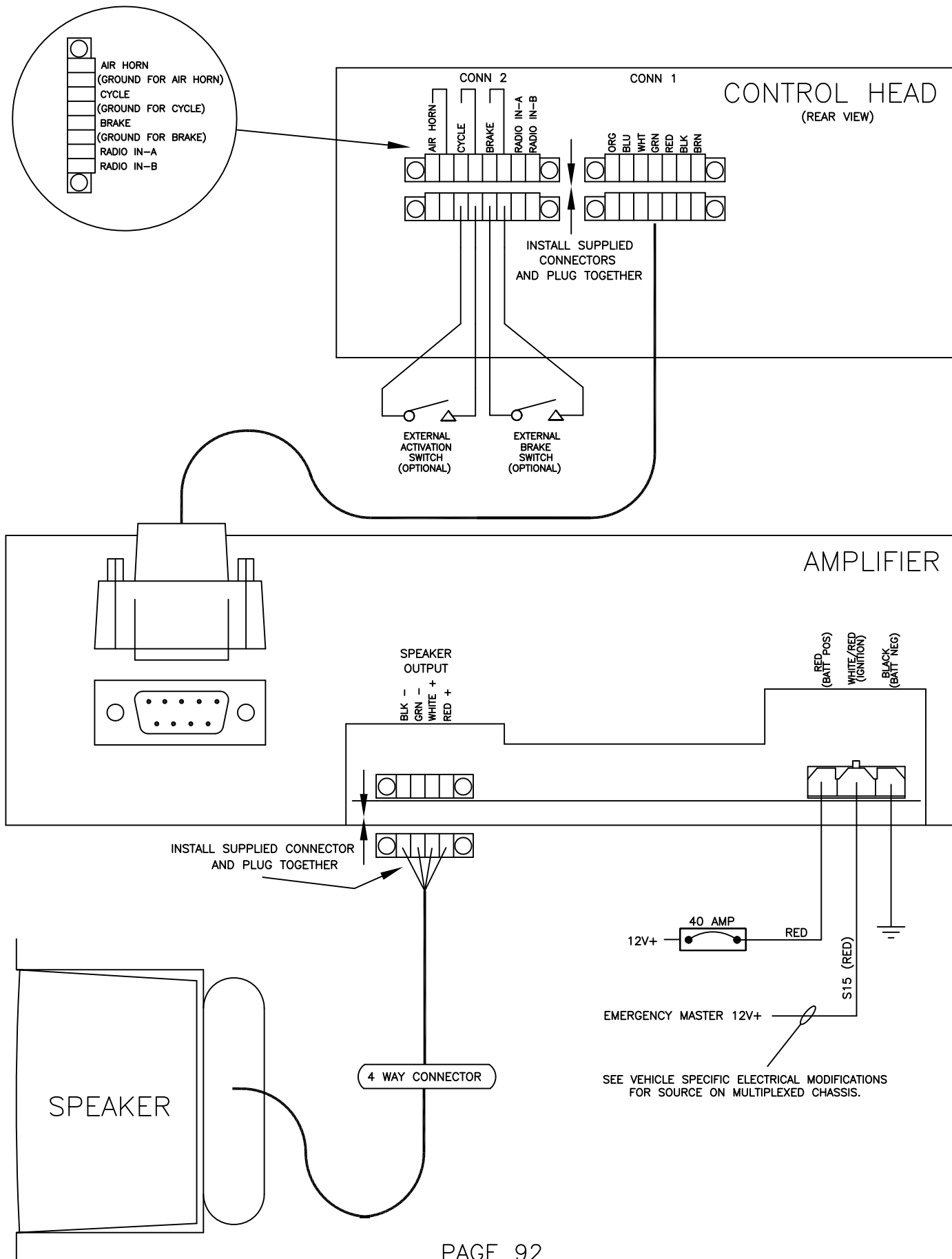

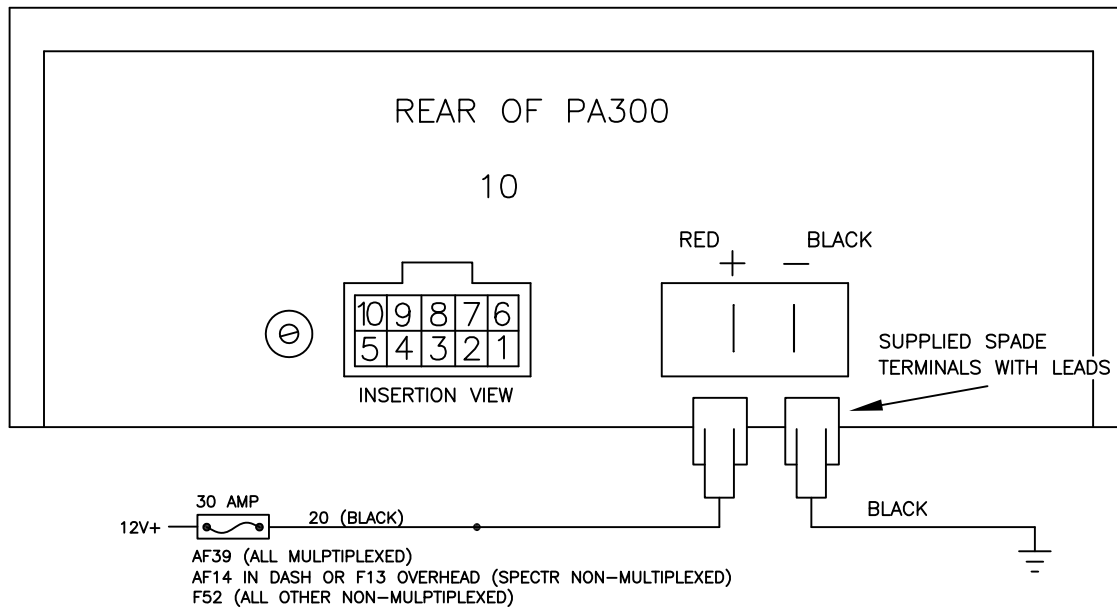

- 1 BROWN (NON RIBBED) RADIO
- 2 BROWN (RIBBED) RADIO
- 3 NO WIRE
- 4 WHITE/YELLOW (HORN RING)
- 5 WHITE (HORN)
- 6 NO WIRE
- 7 BLUE (SPEAKER COMMON)
- 8 BROWN (SPEAKER HI)
- 9 ORANGE (SPEAKER LO)
- 10 NO WIRE

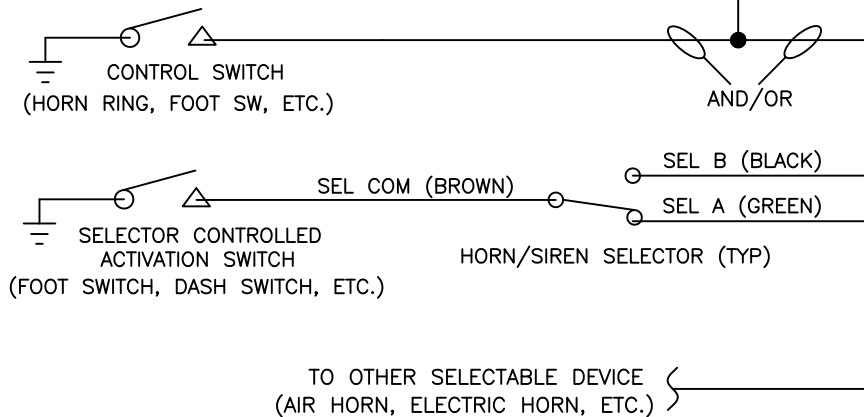
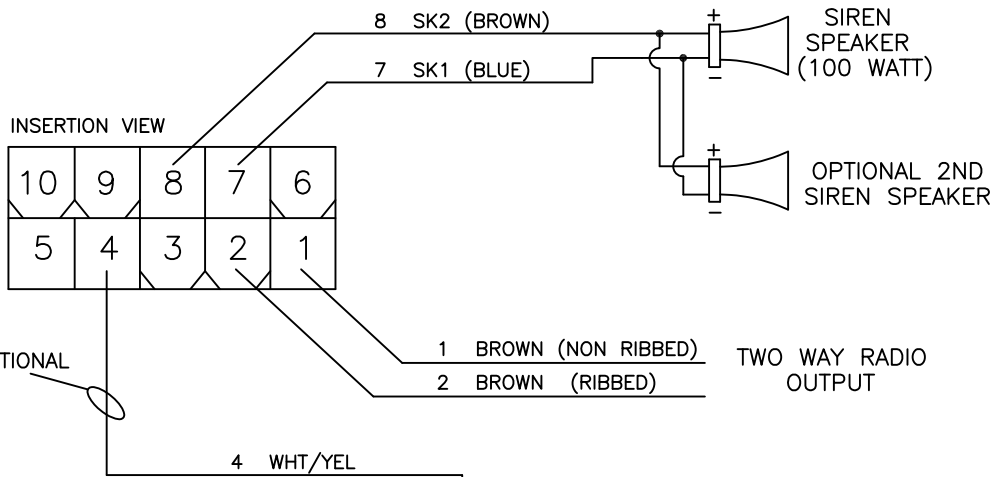

SEE VEHICLE SPECIFIC ELECTRICAL MODIFICATIONS FOR SELECCORS ON MULTIPLEXED CHASSIS.

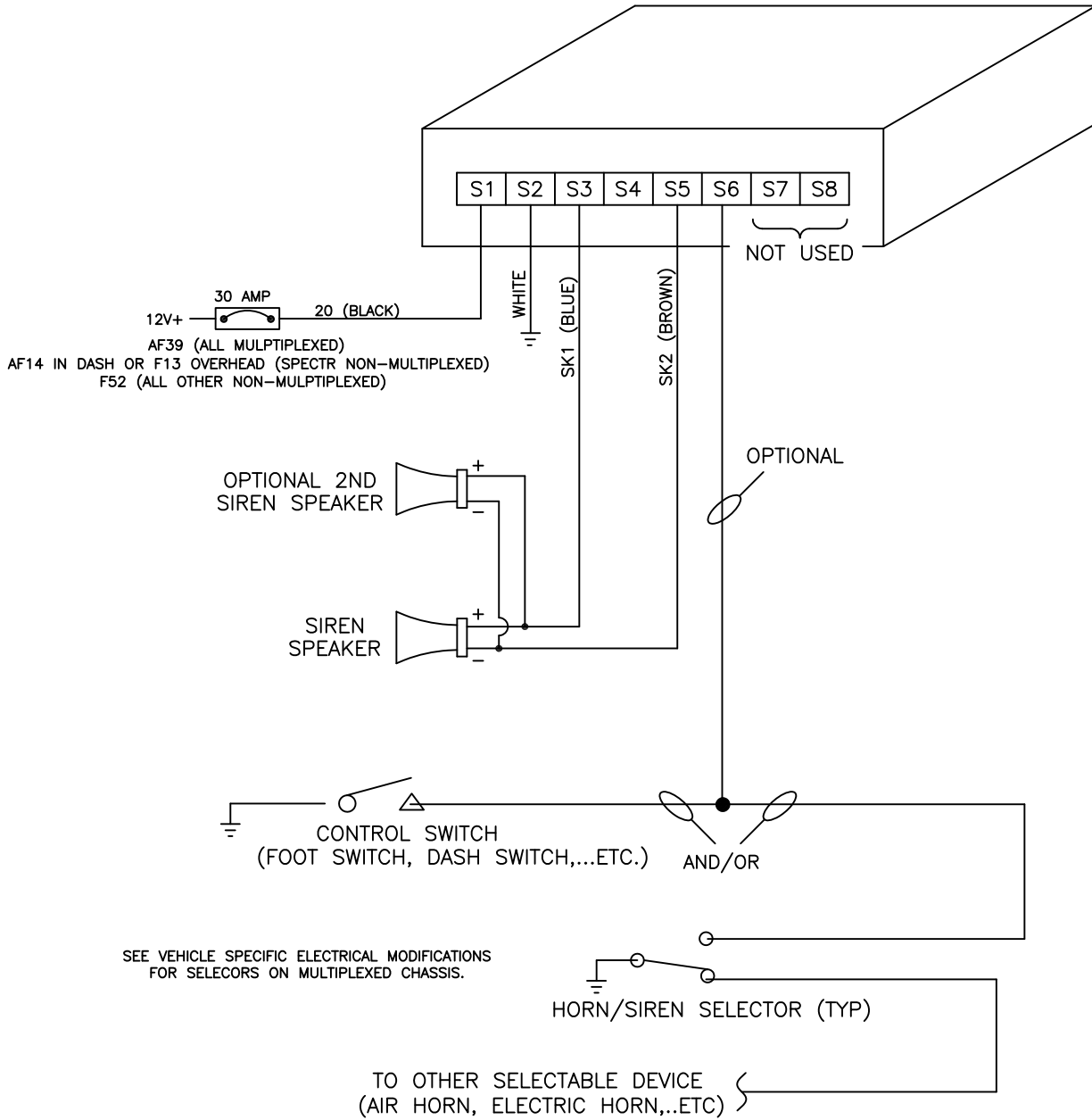

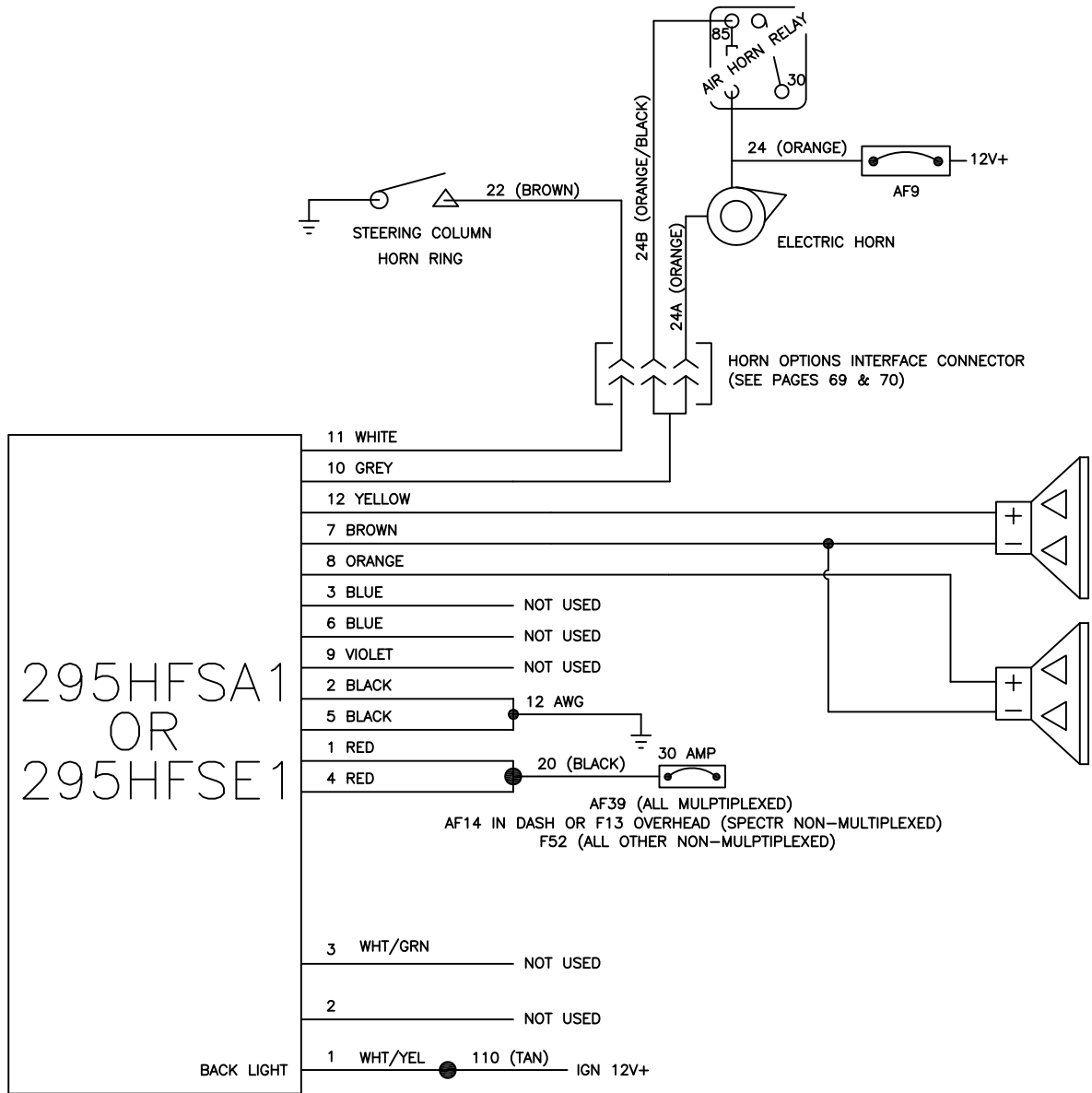

VEHICLE DATA RECORDER

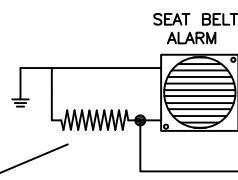
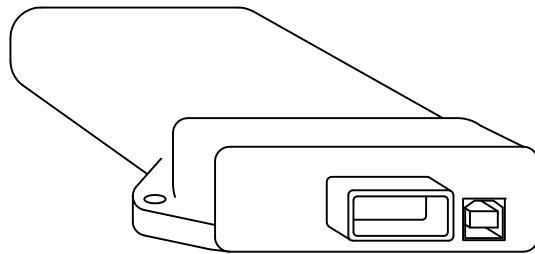

1/2W, 1.5K OHM RESISTOR (HME P/N 89489-70)
TYPICALLY LOCATED ACCROSS POSITIVE AND NEGATIVE
TERMINALS ON ALARM.

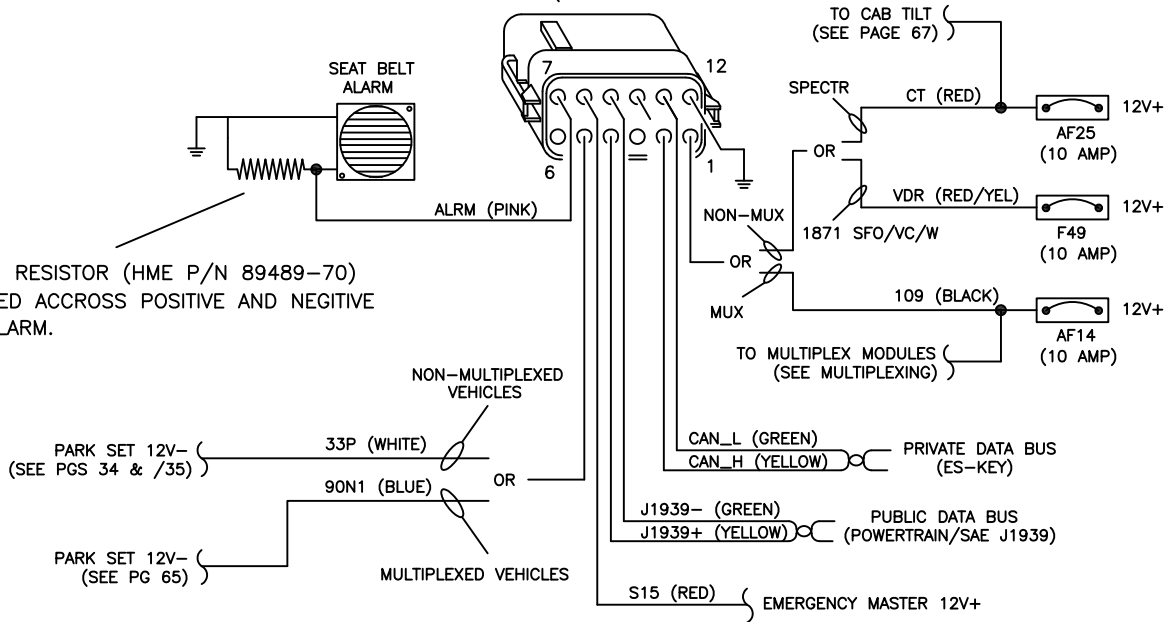

OPTIONS

VEHICLE DATA RECORDER/ SEAT BELT WARNING SYSTEM

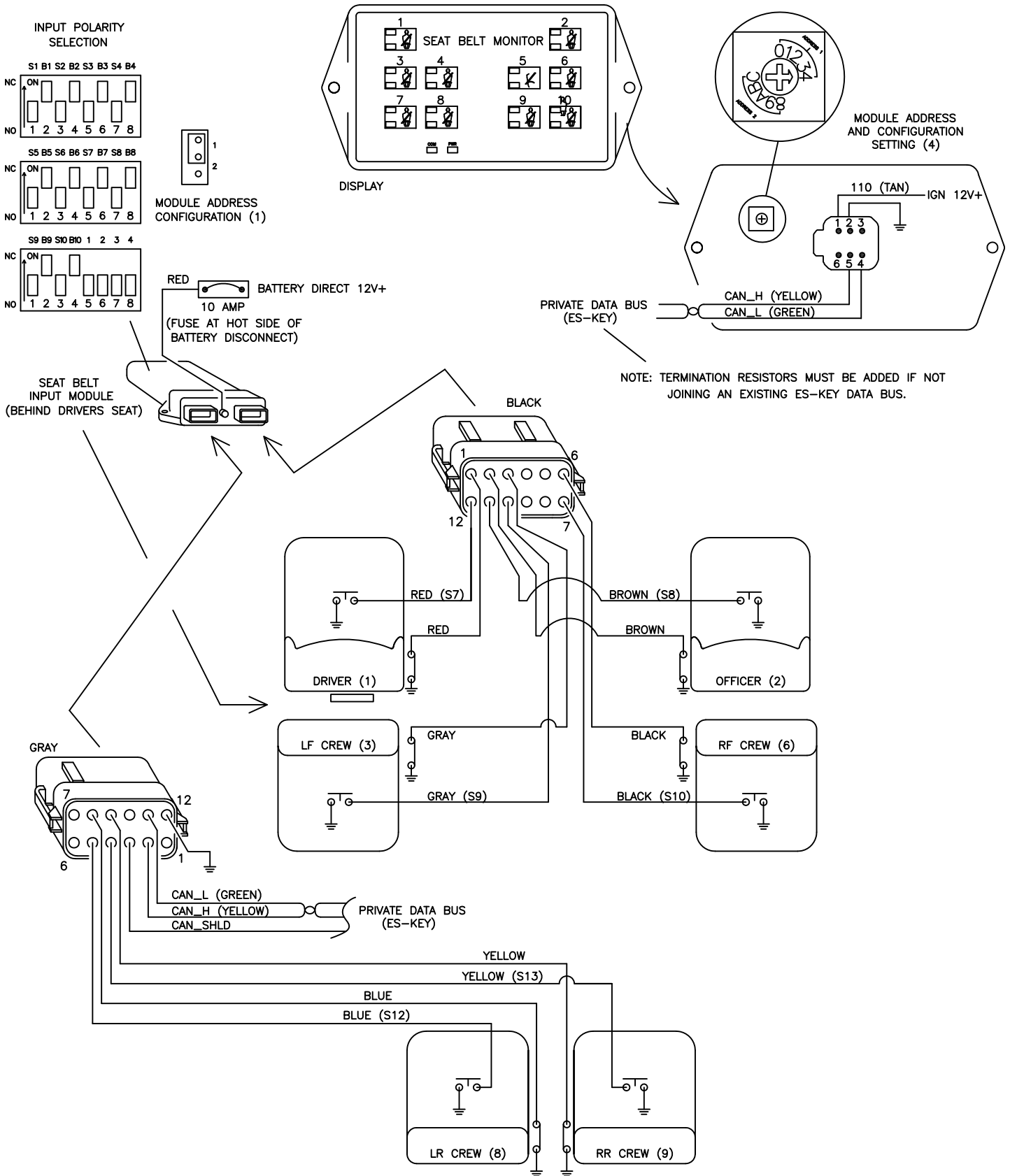

STANDARD SEATING ARRANGEMENT

SEE VEHICLE SPECIFIC ELECTRICAL MODIFICATIONS IF AN ALTERNATIVE SEATING ARRANGEMENT IS USED.

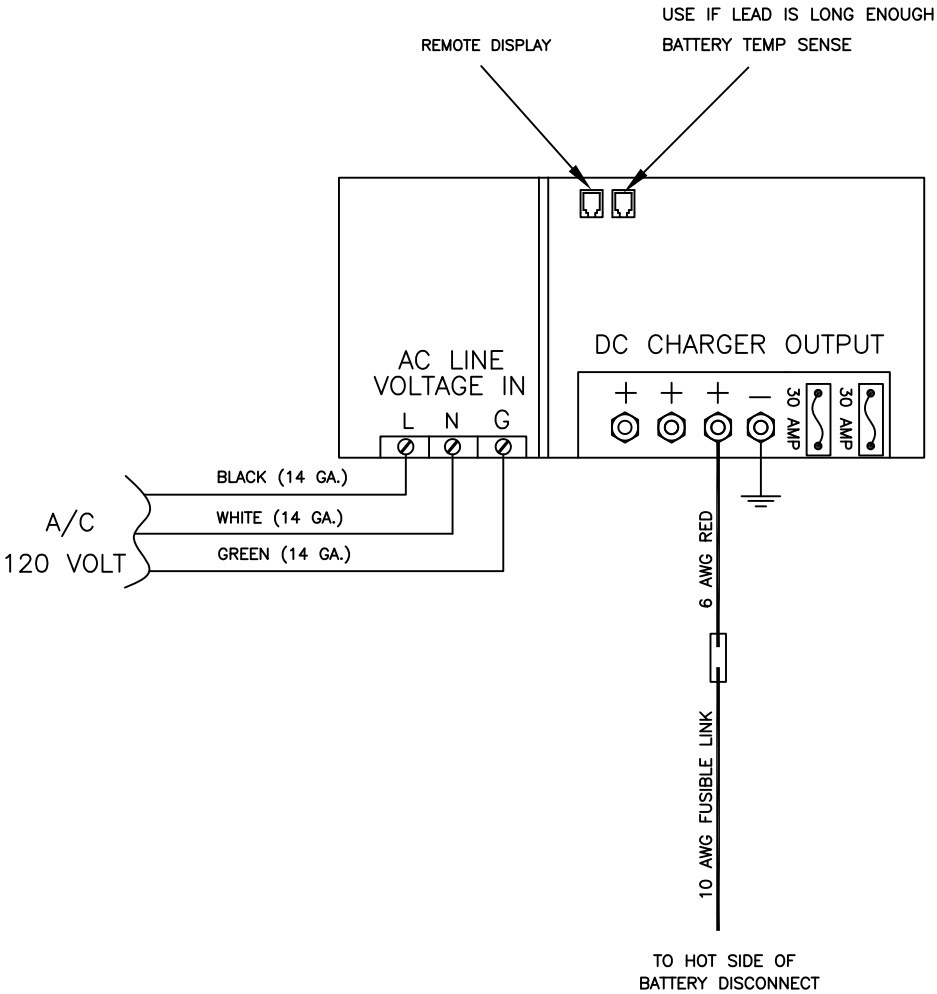

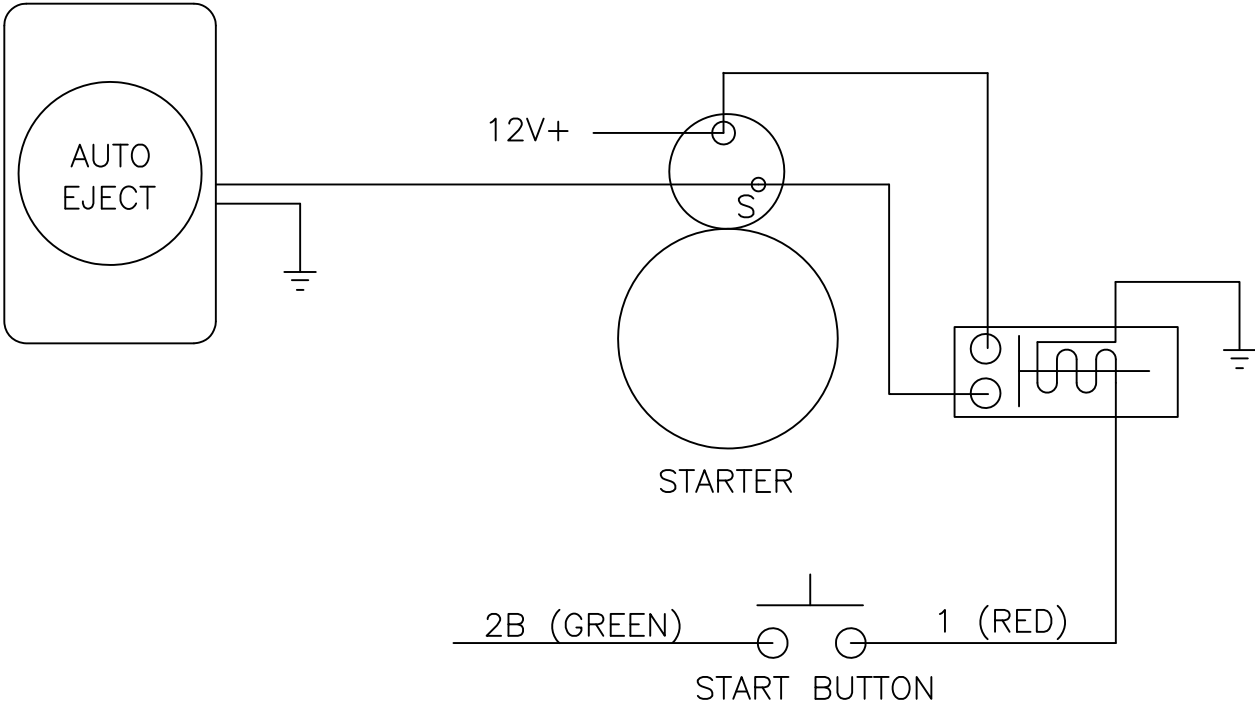

COMMONLY USED SYMBOLS

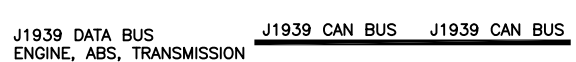
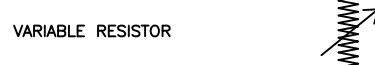
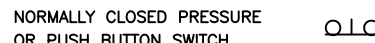
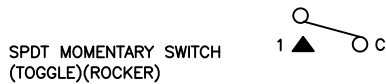

MAINTENANCE

The batteries and their connections should be cleaned and inspected annually (more often if conditions are severe). Apply corrosion inhibitor to all contacts. Inspect all frame rail ground connections and service as necessary. Clean and apply a thin layer of high temperature automotive grease to the contact surfaces, assemble, and seal connection with electrical insulating varnish. Inspect and service alternator belt with others during regular maintenance check ups.

TROUBLESHOOTING HINTS

- 1) Make a photocopy of the page(s) detailing the circuit in question. Highlight and study the circuit to gain a thorough understanding of it. Remember that the entire circuit includes the ground path and voltage source.
- 2) Use a process of elimination and keep a written detailed record of each test performed. this will help reduce "retesting" circuits.
- 3) Avoid low quality meters when testing sensitive circuitry (such as throttle position sensors) as the low impedance tends to "load" the circuit providing invalid test results.

OHMS LAW

V=Volts

I=Current in amperes

R=Resistance in ohms

P=Power in watts

$$V=IR \text{ or } P/I \text{ or } \sqrt{PR}$$

$$I=V/R \text{ or } P/V \text{ or } \sqrt{P/R}$$

$$R=V/I \text{ or } P/I \text{ or } V^2/P$$

$$P=VI \text{ or } V^2/R \text{ or } I^2 R$$

DATE	PG	CHANGE DESCRIPTION
5/18/10		ALL..... ORIGINAL RELEASE
5/25/10 REV. B		42, 50, 51, 83, 86, & 87..... REVISED TO DEPICT CARLING V-SERIES SWITCHES
9/24/10 REV. C		ADDED GROUND CABLE FROM BATTERY GROUND AT FRAME TO FRAME SEE PG. 61 & 63 CHANGED GROUND CABLE FROM ENGINE TO FRAME TO ENGINE TO STARTER SEE PG. 61
3/10/11 REV. D		72B..... CHANGED PRODUCTION AIR HORN WIRING FROM GROUND SWITCHED TO POWER SWITCHED SOLENOID
2/4/13		ADDED SYMBOL OF CIRCUIT BREAKER TO ALL CIRCUITS PROTECTED WITH BREAKERS
2/4/13		9, 10..... ADD REMOTE ACCELERATOR (AR12) & REMOTE PTO (AR15) RELAYS
2/4/13		9, 10..... ADD FLUID LEVEL POWER (AR20) RELAY
2/4/13		27..... ADD USM II INFORMATION
2/5/13 REV. E		67..... UPDATE CAB TILT WIRING
		ADDED PULL DOWN RESISTORS TO ILB +12 VOLT INPUTS SEE PG. 46
REV. F		ADDED AUTO-EJECT WIRING SEE PG. 99 UPDATED ALTERNATING HEADLIGHTS TO MATCH LATEST MODULE SEE PG. 35 CHANGED GAUGE PACKAGE FROM MEDALLION TO AMETEK SEE PG. 44-49 AND 70-71