

THIS DRAWING IS AN OVERALL REPRESENTATION OF THE APPARATUS AS PROPOSED.

THE EXACT DIMENSIONS, LOCATIONS OF ACCESSORIES AND/OR COMPONENTS MAY BE REVISED PENDING COMPLETE ENGINEERING OF THE CUSTOM REQUIREMENTS OF THE INDIVIDUAL APPARATUS ORDER.

IF THERE IS A DISCREPANCY BETWEEN THE BODYBUILDER PRINT AND THE WRITTEN PROPOSAL, THE SPECIFICATIONS WITHIN THE PROPOSAL PREVAIL.

This drawing along with any changes made and Initialed by both the "Fire Department" & HME, Inc. represents what will be constructed and supplied to the "Fire Department." Any changes to the contract specifications and drawing after today's date will be addressed via appropriate change order signed and approved by both the "Fire Department" & HME, Inc.

APPROVED BY: \_\_\_\_\_ TITLE: \_\_\_\_\_  
FIRE DEPARTMENT

APPROVED BY: \_\_\_\_\_ TITLE: \_\_\_\_\_  
HME, Incorporated

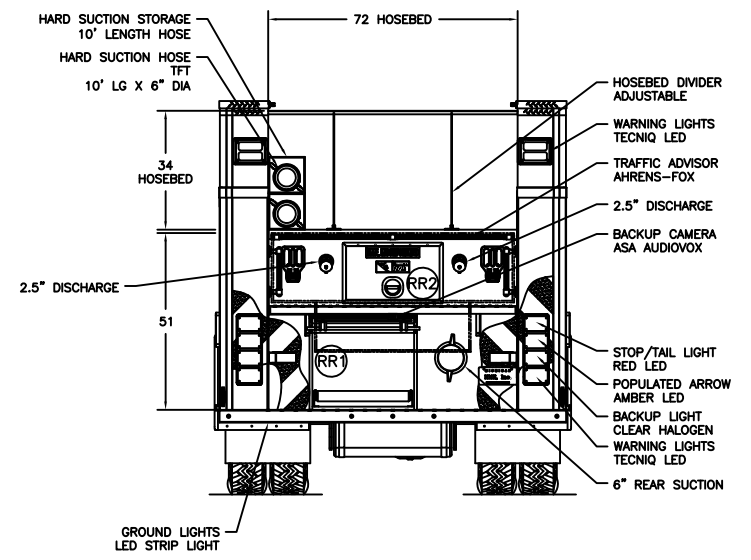
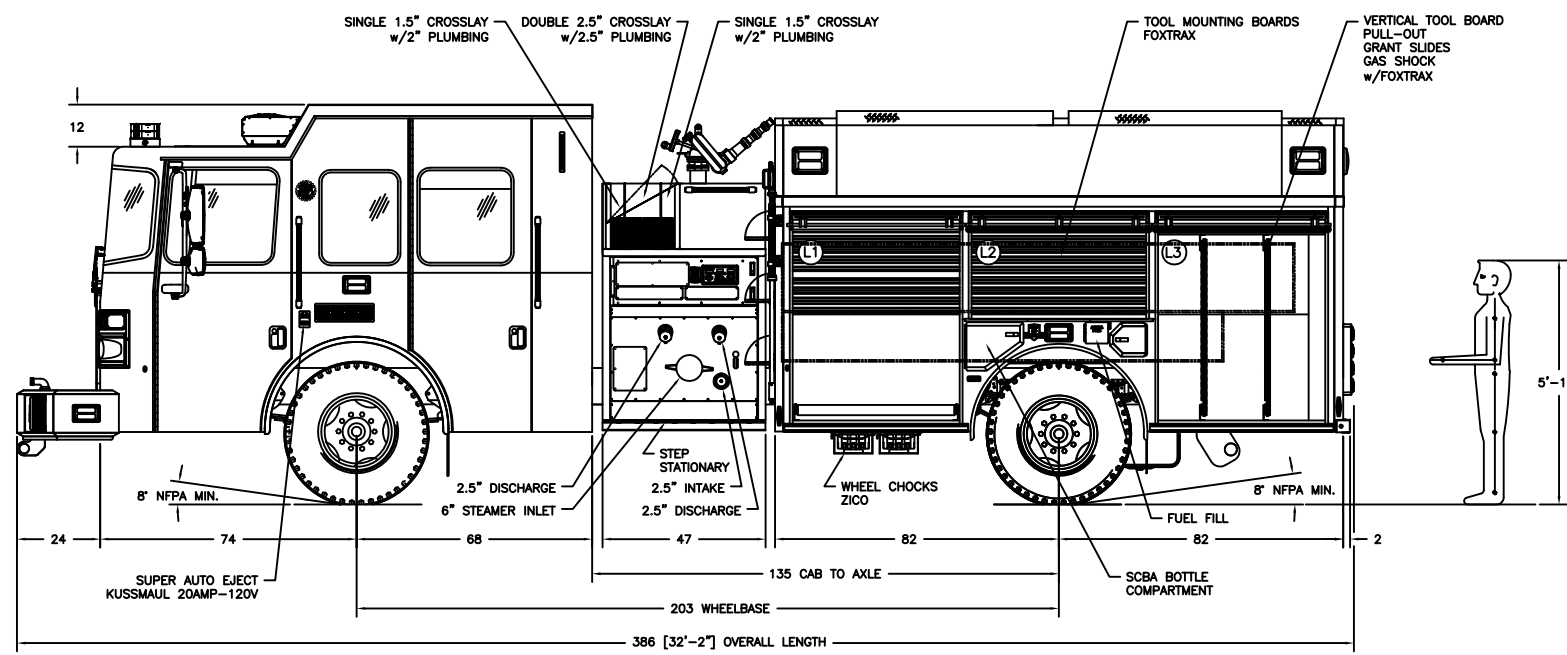
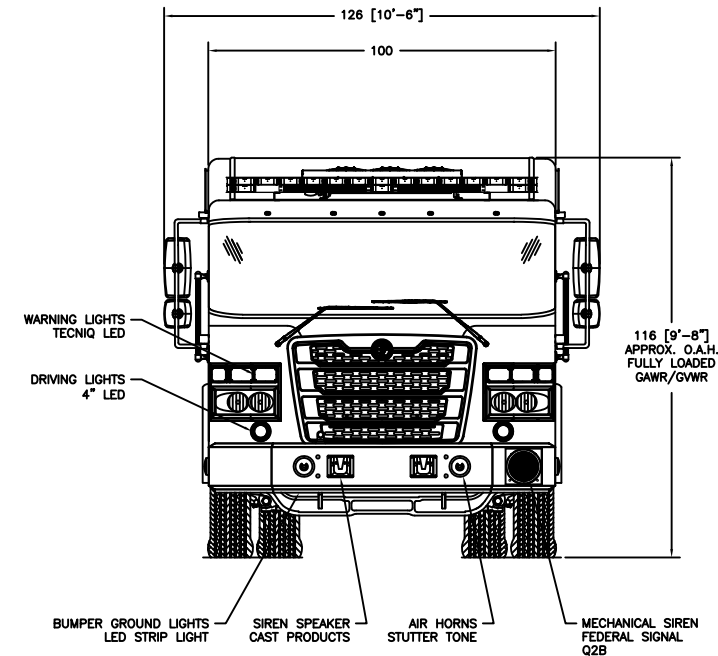
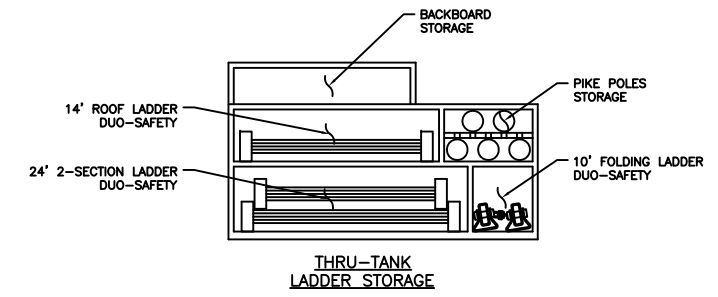
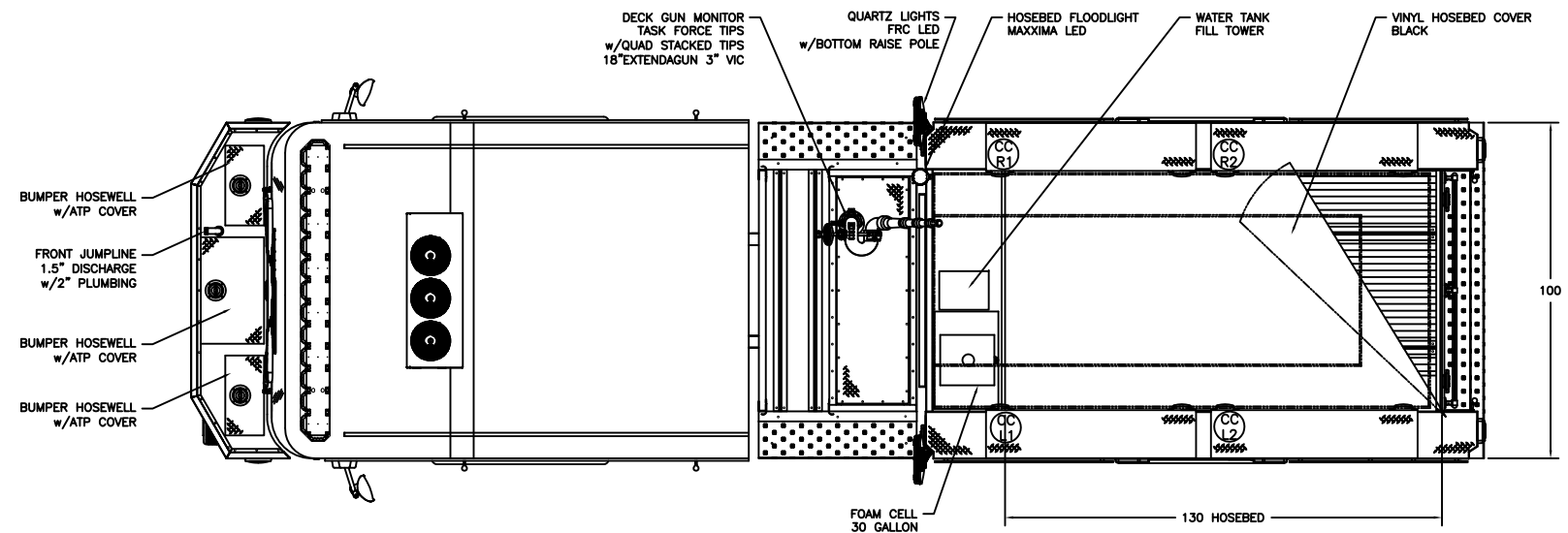

COMPARTMENTATION						
COMPT.	BEHIND DOOR			CLEAR OPENING		COMPT. VOLUME
	WIDTH	HEIGHT	DEPTH	DOOR WIDTH	DOOR HEIGHT	
L1:LOWER	56"	30"	24"	47"	55"	23.3 FT <sup>3</sup>
L1:UPPER	56"	33"	12"	47"	55"	12.8 FT <sup>3</sup>
L2:	52"	33"	12"	49½"	24½"	11.9 FT <sup>3</sup>
L3:LOWER	51"	30"	24"	47½"	55"	21.3 FT <sup>3</sup>
L3:UPPER	51"	33"	12"	47½"	55"	11.7 FT <sup>3</sup>
R1:LOWER	56"	30"	24"	47"	55"	23.3 FT <sup>3</sup>
R1:UPPER	56"	33"	12"	47"	55"	12.8 FT <sup>3</sup>
R2:	52"	33"	12"	49½"	24½"	11.9 FT <sup>3</sup>
R3:LOWER	51"	30"	24"	47½"	55"	21.3 FT <sup>3</sup>
R3:UPPER	51"	33"	12"	47½"	55"	11.7 FT <sup>3</sup>
CCL1:	128"	12"	24"	62½"	11½"	21.3 FT <sup>3</sup>
CCL2:				62½"	11½"	
CCR1:	128"	12"	24"	62½"	11½"	21.3 FT <sup>3</sup>
CCR2:				62½"	11½"	
RR1:	48"	29"	22"	29"	20½"	17.7 FT <sup>3</sup>

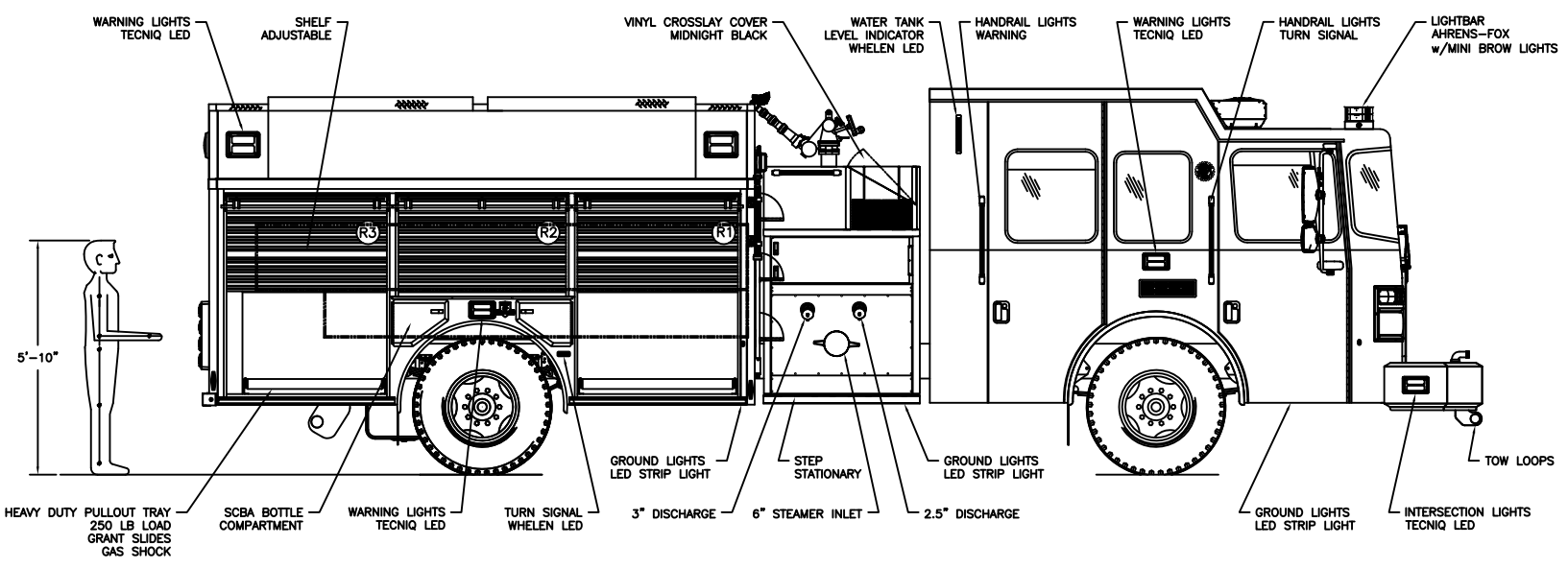

A	DM	29 JAN '19	ORIGINAL RELEASE
LET	BY	DATE	REVISION

**HME INCORPORATED** 1950 BYRON CENTER AVE. WYOMING, MI. 49519

THIS PRINT IS PROVIDED ON A RESTRICTED BASIS AND IS NOT TO BE USED IN ANY WAY DETRIMENTAL TO THE INTERESTS OF HME, INC.

NAME: **AF1 - 47S - #11**

DRAWN D. MEAD	DATE 29 JAN '19	APPROVED N/A	DRAWING FILE 23320 - AF1 - 47S - #11.DWG
THIRD ANGLE PROJECTION	SIZE B	NUMBER 23320	SCALE NTS
			SHEET 1 OF 1

CREATED WITH AutoCAD®