

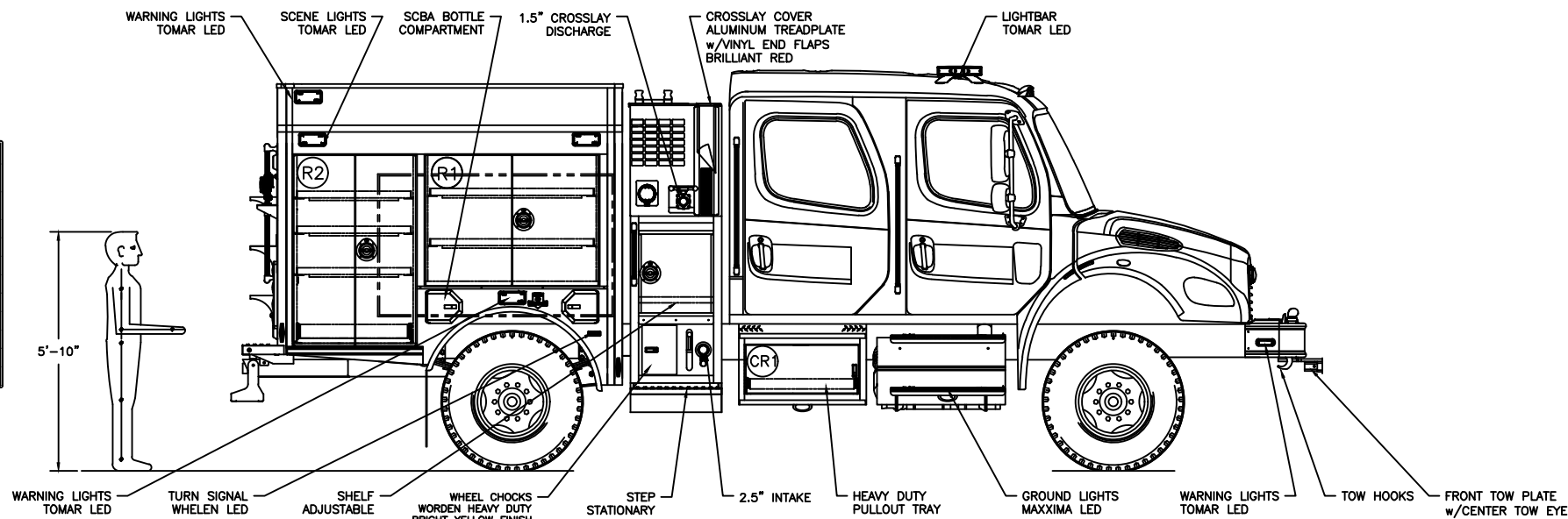

THIS DRAWING IS AN OVERALL REPRESENTATION OF THE APPARATUS AS PROPOSED.

THE EXACT DIMENSIONS, LOCATIONS OF ACCESSORIES AND/OR COMPONENTS MAY BE REVISED PENDING COMPLETE ENGINEERING OF THE CUSTOM REQUIREMENTS OF THE INDIVIDUAL APPARATUS ORDER.

IF THERE IS A DISCREPANCY BETWEEN THE BODYBUILDER PRINT AND THE WRITTEN PROPOSAL, THE SPECIFICATIONS WITHIN THE PROPOSAL PREVAIL.

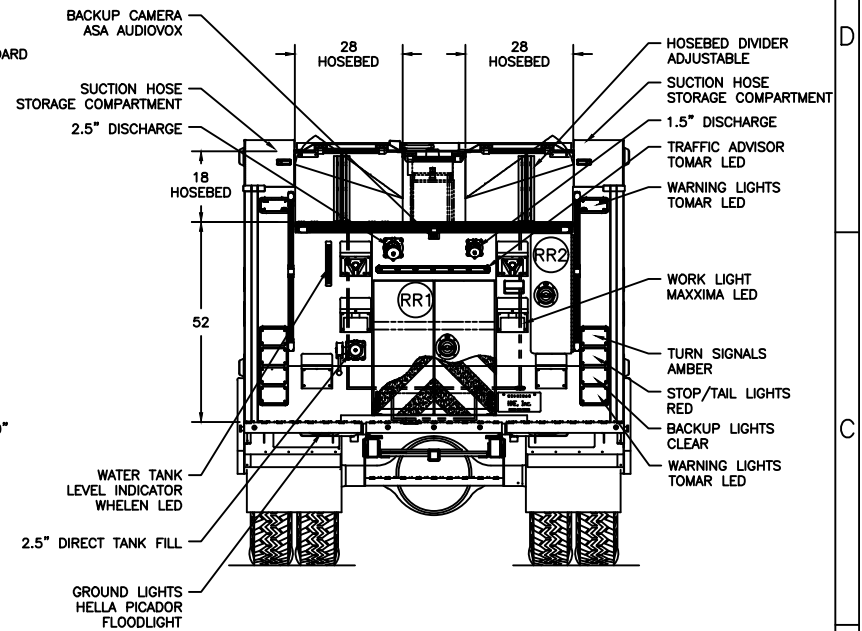
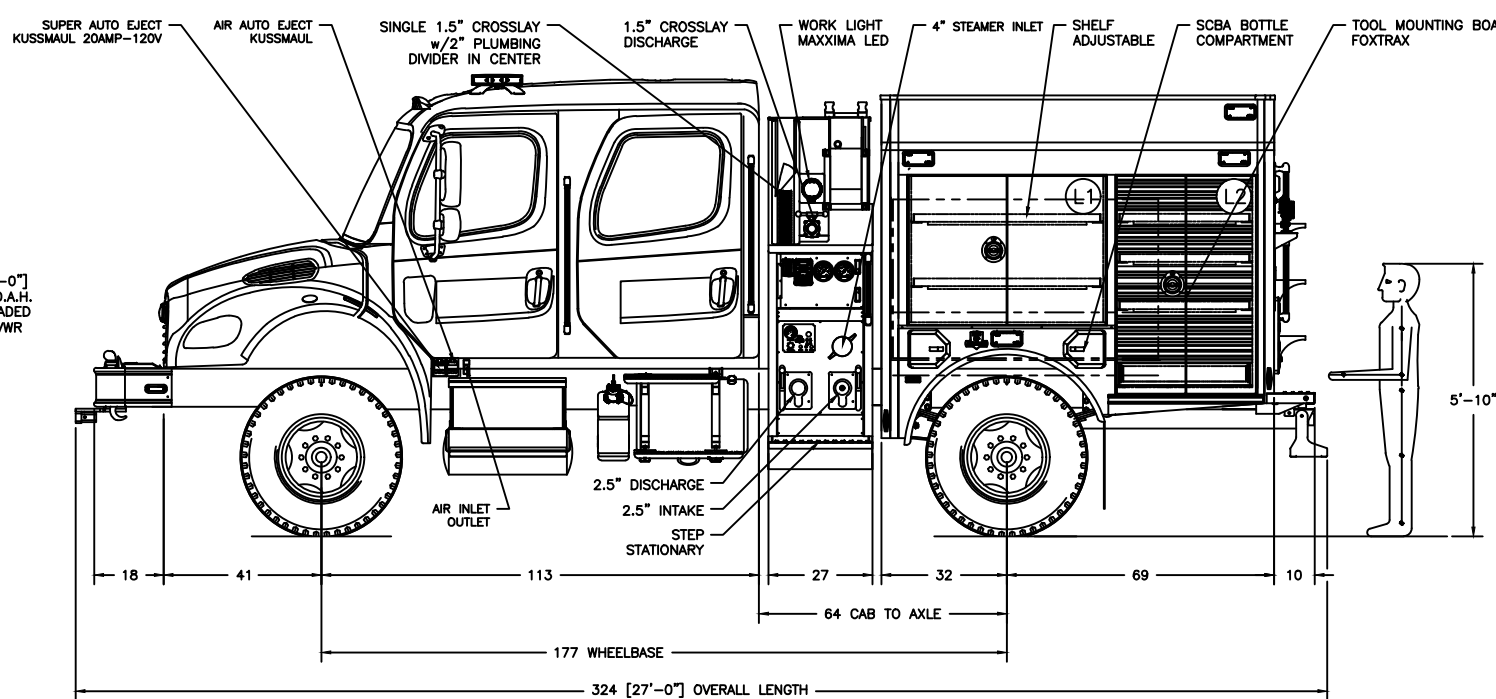
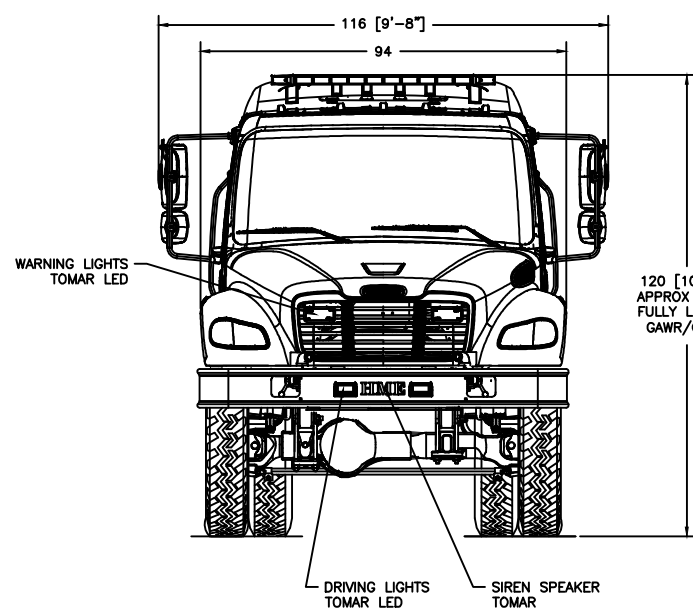
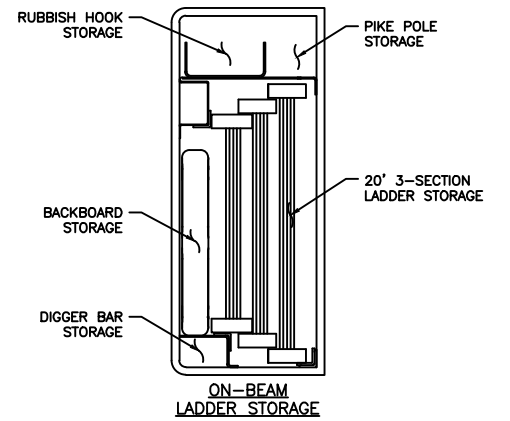
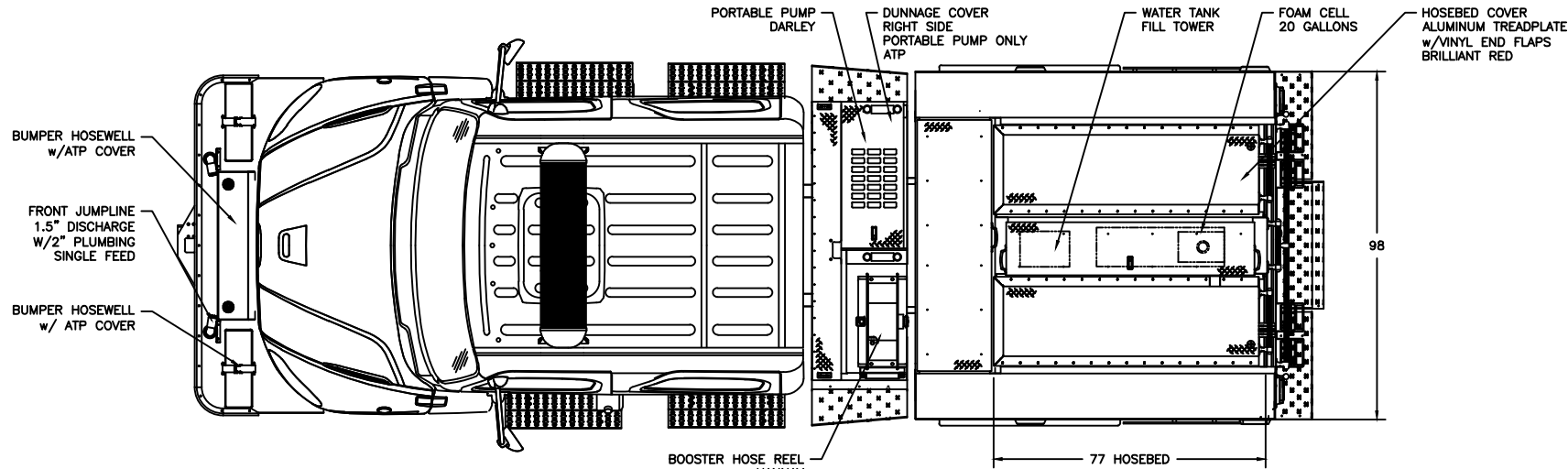

COMPARTMENTATION						
COMPT.	BEHIND DOOR			CLEAR OPENING		COMPT. VOLUME
	WIDTH	HEIGHT	DEPTH	DOOR WIDTH	DOOR HEIGHT	
L1: UPPER	51.5"	10.5"	11"	49.5"	37"	3.4 FT ³
L1: LOWER	51.5"	32"	23"	49.5"	37"	21.9 FT ³
L2: UPPER	38.5"	10.5"	11"	34"	54.5"	2.6 FT ³
L2: LOWER	38.5"	49.5"	23"	34"	54.5"	25.3 FT ³
R1:	51.5"	42.5"	11"	49.5"	37"	13.9 FT ³
R2: UPPER	38.5"	43"	11"	34"	54.5"	10.5 FT ³
R2: LOWER	38.5"	17"	23"	34"	54.5"	8.7 FT ³
CR1:	37"	13"	22.5"	31"	10"	6.2 FT ³
RR1:	48"	48.5"	26.5"	30"	34"	35.7 FT ³

A	JC	01 MAY '23	ORIGINAL RELEASE	
LET	BY	DATE	REVISION	
 1950 BYRON CENTER AVE. WYOMING, MI. 49519				
THIS PRINT IS PROVIDED ON A RESTRICTED BASIS AND IS NOT TO BE USED IN ANY WAY DETRIMENTAL TO THE INTERESTS OF HME, INC.				
NAME 24099 - MODEL 34				
DRAWN J. CROSBY	DATE 01 MAY '23	APPROVED N/A	DRAWING FILE 24099 - MODEL 34	
THIRD ANGLE PROJECTION	SIZE B	NUMBER 24099	SCALE NTS SHEET 1 OF 1	

CREATED WITH AutoCAD®